

SMART ROTARY EGLU AUTODOOR

Assembly guide



Omlet

READY TO GO AUTO?

Your new Rotary Autodoor is here, and with a few simple steps you can have it up and running like clockwork.

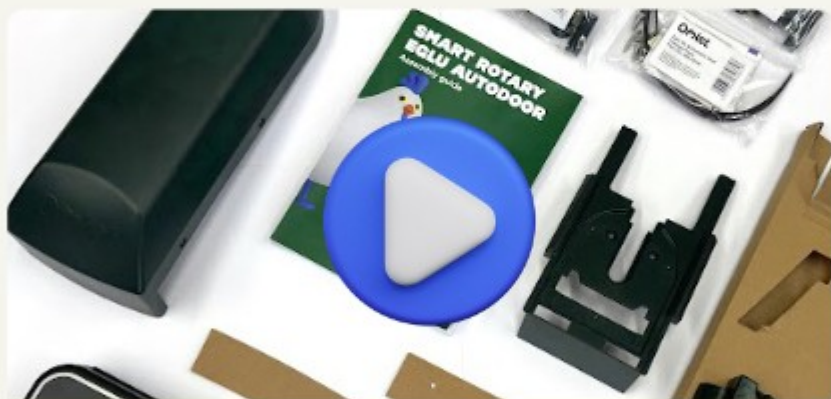

Watch our step by step video to get it right first go.



www.omlet.us/how_to_build

DE Sehen Sie sich jetzt das 'Wie baut man?' Video an

FR Regardez maintenant le tutoriel d'assemblage

NL Bekijk nu de instructievideo

IT Guarda adesso il video di montaggio

ES Puedes ver el video de montaje ahora

SE Titta på instruktionsvideon nu

DK Se instruktionsvideoen nu

SMART MOVE

Scan to download the Omlet app and make your Autodoor smart. If only being smart were always that simple.

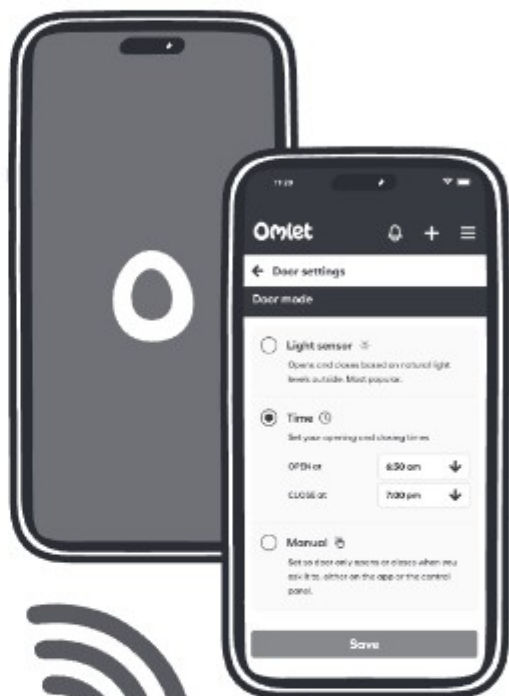

- Omlet's Smart Rotary Eglu Autodoor is designed for use solely as an automated way to open and close access to a chicken coop. It is not a device that will care for your chickens. As the owner you will still need to carry out all the routine daily checks to ensure the health and safety of your chickens, such as ensuring your chickens have access to food and water.
- Please read the instruction manual provided before using this product.
- You must follow the assembly instructions to make sure the product works as intended.
- The product is only to be used for its intended purpose.
- There is a danger of trapping your chickens so keep the product free from dirt and obstructions in order to ensure correct operation of the crush detector.
- The Smart Rotary Eglu Autodoor is designed for use with adult chickens. Disable product if there are chickens under 15 weeks of age in the chicken house.
- Check your chickens every morning to ensure they have access to food and water.
- Do not rely solely on this product to care for your chickens.
- Keep your fingers away from the moving door.
- Ensure excess cable is stowed to avoid tripping or accidental pulling.
- Make sure that the control panel is completely assembled before turning the power on.
- Do not disassemble the control panel when it is wet.
- Ensure that the product is securely attached before it is operated.
- Children must be supervised when using the Smart Rotary Eglu Autodoor - it is not a toy.
- Any other use beyond what is specified shall be considered as improper use. Any direct commercial or industrial use is also deemed to be improper. Omlet is not liable for any damage resulting from such use. The user alone bears the risk.

- Omlets intelligente, drehbare Eglu Autodoor ist ausschließlich zum automatischen Öffnen und Schließen des Zugangs zu einem Hühnerstall bestimmt. Sie wird nicht die Pflege der Hühner übernehmen. Als Besitzer der Tiere werden Sie sich auch weiterhin täglich um die Gesundheit und Sicherheit Ihrer Hühner kümmern müssen, dazu gehört zum Beispiel, dass Sie sicherstellen, dass die Tiere Zugang zu Futter und Wasser haben.
- Bitte lesen Sie die mitgelieferte Betriebsanleitung, bevor Sie dieses Produkt verwenden.
- Sie müssen der Montage- und Bedienungsanleitung folgen, um sicherzustellen, dass das Produkt wie vorgesehen funktioniert.
- Das Produkt ist nur für den vorgesehenen Zweck zu verwenden.
- Es besteht die Gefahr, dass Ihre Hühner eingeklemmt werden, halten Sie daher das Produkt frei von Schmutz und Hindernissen, um den korrekten Betrieb der Sicherheitssensoren zu gewährleisten, die dies verhindern sollen.
- Die Autodoor ist für die Verwendung mit erwachsenen Hühnern vorgesehen. Deaktivieren Sie das Produkt, wenn sich Hühner im Alter von unter 15 Wochen im Hühnerhaus befinden.
- Sehen Sie jeden Morgen nach Ihren Hühnern, um sicherzugehen, dass sie Zugang zu Futter und Wasser haben.
- Verlassen Sie sich nicht ausschließlich auf dieses Produkt, um Ihre Hühner zu betreuen.
- Halten Sie Ihre Finger von der sich bewegenden Tür fern.
- Stellen Sie sicher, dass überschüssiges Kabel sicher verstaut ist, um Stolpern oder versehentliches Ziehen zu vermeiden.
- Vergewissern Sie sich, dass das Bedienfeld vollständig montiert ist, bevor Sie den Strom einschalten.
- Nehmen Sie das Bedienfeld nicht auseinander, wenn es nass ist.
- Vergewissern Sie sich, dass das Produkt sicher befestigt ist, bevor es in Betrieb genommen wird.
- Kinder müssen bei der Verwendung der Automatischen Hühnerstaltür beaufsichtigt werden - sie ist kein Spielzeug.
- Jede andere als die angegebene Verwendung gilt als nicht bestimmungsgemäß. Jegliche direkte gewerbliche oder industrielle Nutzung gilt ebenfalls als nicht bestimmungsgemäß. Omlet haftet nicht für Schäden, die sich aus einer solchen Verwendung ergeben. Das Risiko trägt allein der Benutzer.

- La Porte Automatique intelligente rotative Eglu d'Omlet est conçue pour être utilisée uniquement comme un moyen automatisé d'ouvrir et de fermer l'accès à un poulailler. Cet accessoire ne vous aidera pas à prendre soin de vos poules à proprement parler : vous devrez toujours effectuer vos contrôles de routine quotidiens pour vérifier que vos poules sont en bonne santé et en sécurité et qu'elles ont de l'eau et de la nourriture à disposition.
- Veuillez consulter le manuel fourni avant d'utiliser ce produit.
- Suivez attentivement la notice d'installation pour vous assurer que la Porte Automatique Omlet fonctionne normalement.
- Ce produit ne doit être utilisé que pour l'usage pour lequel il est a été conçu.
- Vos poules risquent de rester coincées dans ce produit. Veuillez enlever tout objet ou toute saleté afin que le détecteur de collision puisse fonctionner correctement.
- La porte automatique a été conçue pour être utilisée par des poules adultes. Veuillez désactiver le produit si vous gardez des poules âgées de moins de 15 semaines dans votre poulailler.
- Assurez-vous que vos poules disposent d'assez d'eau et de nourriture tous les matins.
- Ne comptez pas que sur ce produit pour vous occuper de vos poules.
- N'insérez pas vos doigts dans la porte quand elle s'ouvre ou se ferme.
- Veillez à ce que le câble soit rangé correctement pour éviter qu'il ne soit tiré ou ne fasse tomber quelqu'un par accident.
- Assurez-vous que le tableau de bord soit correctement assemblé avant de l'allumer.
- Ne démontez pas le tableau de bord s'il a été mouillé.
- Assurez-vous que le produit ait été attaché fermement avant de l'utiliser.
- Les enfants utilisant la Porte Automatique Omlet doivent être supervisés par des adultes (ce n'est pas un jouet).
- Tout usage de la Porte Automatique Omlet au-delà de ceux pour lesquels elle est conçue doit être considéré comme inadéquat. Tout usage commercial ou industriel sera également jugé incorrect. Omlet n'est en aucun cas responsable des éventuels problèmes résultant de telles utilisations. L'utilisateur en assumera pleinement les conséquences.

- De slimme, roterende Eglu Autodoor van Omlet is uitsluitend bedoeld voor het automatisch openen en sluiten van de toegang tot een kippenhok. Het is geen apparaat dat voor uw kippen zorgt. Als eigenaar dient u nog steeds de dagelijkse routinecontroles uit te voeren, zoals het controleren of uw dieren toegang hebben tot voer en water, om de gezondheid en veiligheid van uw kippen te garanderen.
- Lees voor gebruik van dit product de bijgevoegde gebruiksaanwijzing.
- Volg de gebruiksaanwijzing om ervoor te zorgen dat het product naar behoren functioneert.
- Gebruik dit product uitsluitend waarvoor het is bestemd.
- Uw kippen kunnen bekneld raken. Houd het product vrij van vuil en obstructies om een correcte werking van de beknellingsdetector te waarborgen.
- De Autodoor is ontworpen voor gebruik met volwassen kippen. Schakel het product uit als u kippen jonger dan 15 weken in het kippenhok houdt.
- Controleer uw kippen elke morgen om er zeker van te zijn dat ze toegang hebben tot voer en water.
- Vertrouw voor de verzorging van uw kippen niet uitsluitend op dit product.
- Houd uw vingers uit de buurt van de deur wanneer deze sluit
- Verberg het overtollige deel van de kabel om te voorkomen dat u erover struikelt of er per ongeluk aan trekt.
- Zorg ervoor dat het bedieningspaneel volledig is geïnstalleerd voordat u de stroom inschakelt.
- Demonteer het bedieningspaneel niet wanneer deze nat is.
- Zorg ervoor dat het product goed is bevestigd voordat u het in gebruik neemt.
- Houd toezicht op kinderen als zij gebruik maken van de Autodoor - het is geen speelgoed.
- Elk ander gebruik dan aangegeven wordt beschouwd als onjuist gebruik. Ook rechtstreeks commercieel en industrieel gebruik wordt beschouwd als onjuist. Omlet kan niet aansprakelijk worden gesteld voor schade veroorzaakt door dergelijk gebruik. Alleen de gebruiker is hiervoor verantwoordelijk.

- La Smart Autodoor girevole Eglu di Omlet è progettata per essere utilizzata esclusivamente come mezzo automatico per aprire e chiudere l'accesso al pollaio. Questo non è un prodotto che si prende cura dei vostri animali. L'Auto Porta rappresenta un aiuto, dovrete comunque occuparvi delle vostre galline effettuando i vari controlli giornalieri per assicurarvi che siano in salute e abbiano sempre accesso a cibo e acqua.
- Leggere il manuale di istruzioni fornito prima di utilizzare il prodotto.
- Seguire attentamente le istruzioni di assemblaggio in modo da essere sicuri che l'Auto Porta funzioni correttamente come da manuale.
- Il prodotto va utilizzato solo per le finalità previste.
- C'è il pericolo che le galline restino intrappolate per cui mantenete il prodotto libero da sporcizia e ostruzioni in modo da assicurare il corretto funzionamento del rilevatore di schiacciamento.
- La porta automatica è progettata per essere utilizzata da galline adulte. Disabilitate il prodotto se avete delle galline al di sotto delle 15 settimane di età.
- Controllate tutte le mattina le galline per assicurarvi che abbiano accesso a cibo e acqua.
- Non affidatevi solo a questo prodotto per prendervi cura della galline.
- Tenete le dita lontano dalla porta quando è in movimento.
- Assicuratevi che i cavi siano in ordine in modo da essere certi di non tirarli per sbaglio o inciamparci.
- Assicuratevi che il pannello di controllo sia completamente assemblato prima di farlo partire.
- Non smontate il pannello di controllo se è umido.
- Assicuratevi che il prodotto sia correttamente attaccato prima di renderlo operativo.
- L'Auto Porta non è un giocattolo: i bambini devono essere supervisionati da un adulto quando usano il prodotto.
- Ogni uso dell'Auto Porta diverso da quello raccomandato è da considerarsi improprio, così come qualsiasi diretto uso commerciale o industriale. Omlet non è responsabile per danni causati dall'uso dell'Auto Porta. L'acquirente è da considerarsi il solo responsabile.

- La puerta automática inteligente giratoria Eglu de Omlet está diseñada para utilizarse únicamente como medio automatizado de apertura y cierre del acceso a una nave avícola. No es un dispositivo que cuide de tus gallinas por ti. Como criador de gallinas, tendrá que llevar a cabo todas las comprobaciones diarias rutinarias para garantizar la salud y seguridad de sus gallinas, como asegurar que tengan acceso a comida y agua.
- Por favor, lea el manual de instrucciones antes de utilizar este producto.
- Debe seguir las instrucciones de montaje para asegurarse de que el producto funciona según lo previsto.
- Este producto solo debe utilizarse para los fines para los que ha sido diseñado.
- Existe el peligro de que sus gallinas queden atrapadas en la puerta, por lo que debe mantener el producto limpio y libre de obstrucciones para garantizar el correcto funcionamiento del detector de aplastamiento.
- La puerta automática inteligente Eglu está diseñada para su uso con gallinas adultas. Desactive el producto si hay gallinas de menos de 15 semanas en el gallinero.
- Compruebe cada mañana que sus gallinas tienen acceso a comida y agua.
- No confíe únicamente en este producto para el cuidado de sus gallinas.
- Mantenga los dedos alejados de la parte móvil de la puerta.
- Asegúrese de tapar el cable sobrante para evitar tropiezos o tirones accidentales.
- Asegúrese de que el panel de control está completamente montado antes de conectarlo a la corriente.
- No desmonte el panel de control cuando esté mojado.
- Asegúrese de que el producto está bien fijado antes de ponerlo en funcionamiento.
- Los niños deben ser supervisados cuando usen la puerta automática inteligente giratoria Eglu - no es un juguete.
- Cualquier otro uso distinto del especificado se considerará uso indebido. Cualquier uso comercial o industrial directo también se considerará inadecuado. Omlet no se hace responsable de los daños derivados de dicho uso. El usuario es el único responsable.

- Omlets smarta Autodörr till Eglu-hönshus är designad för att endast användas för att automatiskt öppna och stänga ingången till ett hönshus. Det är inte en produkt som tar hand om dina höns. Som ägare måste du fortfarande genomföra alla dagliga rutiner för att se till att dina höns håller sig friska och säkra, t.ex. se till att de har tillgång till mat och vatten.
- Du måste läsa den medföljande bruksanvisningen innan du använder den här produkten.
- Du måste följa instruktionsmanualen för att se till att produkten fungerar som den ska.
- Produkten skall endast användas för avsett ändamål.
- Det är viktigt att produkten hålls fri från smuts och andra blockeringar för att säkerhetssensorn ska fungera, det finns annars en risk att dina höns fastnar.
- Den automatiska dörren har designats för att användas med vuxna höns. Koppla ifrån den om det finns höns som är yngre än 15 veckor i hönshuset.
- Titta till dina höns varje morgon för att se till att de har tillgång till mat och vatten.
- Förlita dig inte enbart på den här produkten för att ta hand om dina höns.
- Håll fingrarna borta från dörren när den är i rörelse.
- Om inte hela kabellängden behövs, se till att den extra längden göms undan för att undvika att någon ramlar eller fastnar och drar i kabeln.
- Se till att kontrollpanelen är monterad enligt instruktionerna innan du kopplar den till en strömkälla.
- Ta inte av kontrollpanelen när den är blöt.
- Se till att produkten har monterats enligt anvisningarna innan den används.
- Barn måste övervakas när de använder autodörren - den är inte en leksak.
- All användning utöver vad som är menat bör ses som olämplig användning. All direkt kommersiell eller industriell användning anses också olämplig. Omlet tar inget ansvar för skador orsakade av denna sorts användning, utan ägaren står för potentiella risker.

- Omlets smarte roterende Eglu Autodoor er designet til udelukkende at blive anvendt som en automatiseret måde at åbne og lukke adgang til et hønses hus på. Enheden kan ikke passe dine høns. Som hønses ejer skal du stadig udføre alle de rutinemæssige daglige opgaver for at sikre dine høns' sundhed og sikkerhed såsom at sørge for, at dine høns har adgang til foder og vand.
- Læs venligst medfølgende brugsanvisning inden du anvender dette produkt.
- Du skal følge brugsanvisningen for at sikre, at produktet fungerer som det skal.
- Produktet må kun bruges til det tilsigtede formål.
- Hold produktet fri for snavs og andre forhindringer for at sikre, at sikkerhedssensoren fungerer korrekt, da der ellers vil være fare for, at dine høns kan blive fanget.
- Den automatiske dør til hønses huset er designet til brug med voksne høns. Deaktiver produktet, hvis der er kyllinger på under 15 uger i hønses huset.
- Se til dine høns hver morgen for at sikre, at de har adgang til foder og vand.
- Stol ikke udelukkende på dette produkt til pasning af dine høns.
- Hold fingrene væk fra døren, når den er i bevægelse.
- Sørg for at overskydende ledning pakkes væk for at undgå at komme til at snuble over eller trække i den.
- Sørg for at kontrolpanelet er fuldstændigt samlet, inden du tænder for strømmen.
- Skil ikke kontrolpanelet ad mens det er vådt.
- Sørg for at produktet er sikkert fastgjort, før det betjenes.
- Børn skal være under opsyn ved brug af den automatiske dør - det er ikke et legetøj.
- Enhver anden anvendelse end den, der er angivet, betragtes som ukorrekt anvendelse. Enhver direkte kommerciel eller industriel anvendelse anses også for ukorrekt. Omlet er ikke ansvarlig for nogen skade som følge af ukorrekt anvendelse. Brugeren alene bærer risikoen.

EN Table of Contents

- | | | | |
|----|---|-----|---|
| 15 | What you have received | 87 | Quickstart Guide |
| 18 | What you will need | 90 | Calibration |
| 20 | Exploded diagrams of Autodoor & Control Panel | 90 | Change Language |
| 23 | Assembly to Eglu Go | 91 | Selecting the mode |
| 38 | Assembly to Eglu Cube | 91 | Manual Mode |
| 53 | Assembly to Eglu Pro | 92 | Time Mode |
| 70 | Control Panel Assembly | 94 | Light Mode |
| 75 | Control Panel Mounting | 138 | Emergency Fail Safe/
Troubleshooting |

DE Inhaltsverzeichnis

- | | | | |
|----|--|-----|--|
| 15 | Das haben Sie erhalten | 87 | Schnellstart-Anleitung |
| 18 | Was Sie brauchen | 96 | Kalibrierung |
| 20 | Explosionszeichnung der Tür und des Steuerelements | 96 | Sprache ändern |
| 23 | Montage am Eglu Go | 98 | Die Wahl des Modus |
| 38 | Montage am Eglu Cube | 97 | Wahl des Modus |
| 53 | Montage am Eglu Pro | 100 | Zeitmodus |
| 70 | Steuerelement anschließen | 100 | Lichtmodus |
| 75 | Montage Steuerelement | 138 | Sicherheit im Notfall/
Fehlerbehebung |

FR Sommaire

- | | | | |
|----|---|-----|----------------------------------|
| 15 | Ce qui est fourni | 87 | Guide de démarrage rapide |
| 18 | Ce dont vous aurez besoin | 102 | Calibrage |
| 20 | Vue éclatée de la Porte Automatique Omlet et du tableau de bord | 102 | Changer la langue |
| 23 | Assemblage pour Eglu Go | 103 | Sélection du mode |
| 38 | Assemblage pour Eglu Cube | 103 | Mode manuel |
| 53 | Assemblage pour Eglu Pro | 104 | Mode horaire |
| 70 | Assemblage du panneau de commande | 106 | Mode luminosité |
| 75 | Montage du panneau de commande | 138 | Sécurité d'urgence/
Dépannage |

NL Inhoudsopgave

- | | | | |
|----|---|-----|---|
| 15 | Wat u heeft ontvangen | 87 | Snelstart handleiding |
| 18 | Wat u nodig heeft | 108 | Afstellen |
| 20 | Exploded diagrams van Autodeur & Bedieningspaneel | 108 | Taal wijzigen |
| 23 | Montage aan Eglu Go | 109 | De modus selecteren |
| 38 | Montage aan Eglu Cube | 109 | Manual-mode |
| 53 | Montage aan Eglu Pro | 110 | Time-mode |
| 70 | Het bedieningspaneel bouwen | 112 | Daglicht-mode |
| 75 | Bedieningspaneel montage | 138 | Veiligheid bij noodgevallen/
probleemoplossing |

IT Sommario

- | | | | |
|----|---|-----|---|
| 15 | Cosa avete ricevuto | 87 | Guida Rapida |
| 18 | Avete anche bisogno di | 114 | Calibrazione |
| 20 | Diagramma esploso dell'Auto Porta e del Pannello di Controllo | 114 | Cambio lingua |
| 23 | Montaggio su Eglu Go | 115 | Scelta della modalità |
| 38 | Montaggio su Eglu Cube | 115 | Modalità Manuale |
| 53 | Montaggio su Eglu Pro | 116 | Modalità Tempo |
| 70 | Assemblaggio del pannello di controllo | 118 | Modalità Luce |
| 75 | Montaggio del pannello di controllo | 138 | Sistema di sicurezza/
Risoluzione dei problemi |

ES Tabla de contenidos

- | | | | |
|----|--|-----|--|
| 15 | lo que has recibido | 87 | Guía rápida de inicio |
| 18 | Que necesitarás | 120 | Calibración |
| 20 | Diagramas de vistas en detalle de la puerta automática y el panel de control | 120 | Cambiar idioma |
| 23 | Montaje en el Go | 121 | Seleccionando el modo |
| 38 | Montaje en el Cube | 121 | Modo manual |
| 53 | Montaje en el Pro | 122 | Modo reloj |
| 70 | Ensamblaje del panel de control | 124 | Modo luz |
| 75 | Montaje del panel de control | 138 | A prueba de fallos de emergencia/Solución de problemas |

- 15 Vad du har fått
- 18 Vad du behöver
- 20 Exploderade diagram av autodörren och
- 23 Montering till Eglu Go
- 38 Montering till Eglu Cube
- 53 Montering till Eglu Pro
- 70 Kontrollpanelsmontering
- 75 Montering av kontrollpanel
- 87 Snabbguide
- 126 Kalibrering
- 126 Ändra språk
- 127 Välj inställning
- 127 Manuell inställning
- 128 Tidsinställning
- 130 Ljusinställning
- 138 Säker i nödsituationer/
Felsökning

- 15 Hvad du har modtaget
- 18 Hvad du skal bruge
- 20 Exploderede diagrammer af den automatiske dør og kontrolpanelet
- 23 Montering til Eglu Go
- 38 Montering til Eglu Cube
- 53 Montering til Eglu Pro
- 70 Kontrolpanel samling
- 75 Kontrolpanel montering
- 87 Hurtig startvejledning
- 132 Kalibrering
- 132 Skift sprog
- 133 Valg af tilstand
- 133 Manuel funktion
- 134 Tidsindstillet funktion
- 136 Lyssensor funktion
- 138 Sikker i nødsituationer/
Fejlfinding

What you have received

DE Das haben Sie erhalten • **FR** Ce qui est fourni • **NL** Wat u heeft ontvangen
IT Cosa avete ricevuto • **ES** Qué ha recibido • **SE** Vad du har fått
DK Hvad du har modtaget

106.0001 Boxed Rotary Autodoor



x1
Gear Case
106.0005



x1
Base
106.0008



x1
Door Switch
106.0017



x1
Retaining Bracket
106.1002



x1
Control Panel
107.0014



x1
Mounting Plate
014.1135



x1
Switch Template
Go
106.1036

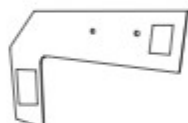

x1
Switch Template
Cube & Pro
106.1037

106.0010 Rotary Autodoor Fixings Pouch



x1

Base Support A
106.0020



x1

Base Support B
106.0021



x1

CP Mount Tape
106.1047



x2

Machine Screw
Pozi Pan
M4 x 8mm
800.0439



x4

Machine Screw
M4 x 9mm
Countersunk
800.0441



x2

Self-Tapping
Plastite Screw
4x20mm
800.0474



x4

Cable Tie
800.0477

106.0012 Rotary Autodoor Go Fixings

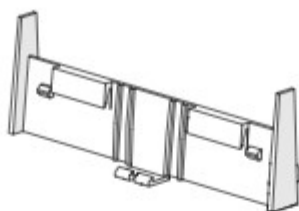

x1
Go
Front Clip
106.1005



x1
Go
Base Foot LH
106.1007



x1
Go
Base Foot RH
106.1008

106.0011 Rotary Autodoor Cube Fixings

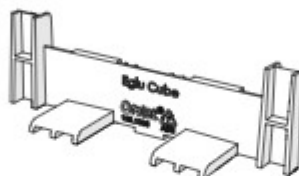

x1
Cube
Front Clip
106.1006



x1
Cube
Base Foot LH
106.1009



x1
Cube
Base Foot RH
106.1010

106.0013 Rotary Autodoor Pro Fixings

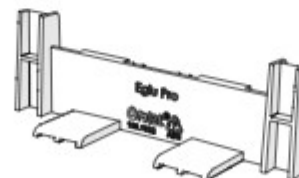
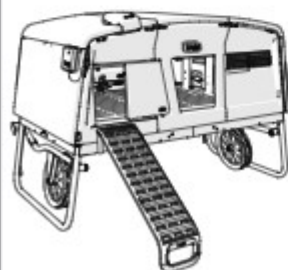

x1
Pro
Front Clip
106.1032



x1
Pro
Base Foot LH
106.1033



x1
Pro
Base Foot RH
106.1034

You will need...

DE Das brauchen Sie... • **FR** Vous aurez besoin de... • **NL** Wat u nodig heeft...
IT Avrai bisogno... • **ES** Necesitará... • **SE** Du behöver... • **DK** Du skal bruge...

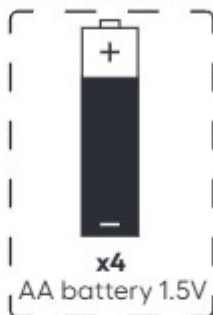

Optional

- **DE** Optional
- **FR** Facultative
- **NL** Optioneel
- **IT** Opzionale
- **ES** Opcional
- **SE** Frivillig
- **DK** Valgfri

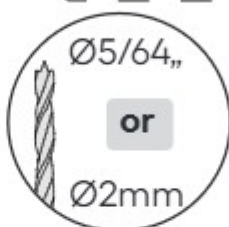

Do not use Power Drill to tighten screws.

- **DE** Verwenden Sie zum Anziehen der Schrauben keinen elektrischen Akkuschauber.
- **FR** N'utilisez pas une perceuse pour serrer les vis.
- **NL** Gebruik voor het aandraaien van schroeven nooit een boormachine.
- **IT** Non utilizzare un trapano per stringere le viti.
- **ES** No utilizar un taladro eléctrico para apretar los tornillos.
- **SE** Använd inte en elektrisk bormaskin för att dra åt skruvarna.
- **DK** Anvend ikke boremaskine til at stramme skruerne.

Cleaning equipment needed (for example alcohol wipes).



- **DE** Benötigte Reinigungsmittel (z. B. Alkoholtücher).
- **FR** Matériel de nettoyage requis (par exemple, lingettes alcoolisées).
- **NL** Benodigde schoonmaakmiddelen (bijvoorbeeld desinfecterende doekjes).
- **IT** Prodotti per la pulizia necessari (ad esempio, salviette imbevute di alcol).
- **ES** Productos de limpieza necesarios (por ejemplo, toallitas con alcohol).
- **SE** Behövlig rengöringsutrustning (till exempel alkoholservetter).
- **DK** Essentielt rengøringsudstyr (f.eks. spritservietter).

Optional Attachment Kits - sold separately

DE Optionale Anbausätze - separat erhältlich

FR Kits de fixation facultatives - vendues séparément

NL Optionele opzetkits - worden afzonderlijk verkocht

IT Kit di attacco opzionali - venduti separatamente

ES Kits de fijación opcionales - se venden por separado

SE Extra tillbehörssatser - säljs separat

DK Valgfri monteringsbeslag - sælges separat

014.0056 Control Panel Mounting Bracket Cube Mk2 & Pro House



x1

Control Panel Mounting Bracket
Cube Mk2 & Pro House
014.0054

Optional Accessories

DE Extra Zubehör - **FR** Accessoires en option - **NL** Optionele accessoires

IT Accessori opzionali - **ES** Accesorios opcionales - **SE** Valbara tillbehör

DK Valgfrit tilbehør



x1

Omlet Coop
Light
014.0062



x1

AD Replacement
Wire
014.0080



x1

12V Power
Adaptor UK
810.0530



x1

12V Power
Adaptor EU
810.0531



x1

12V Power
Adaptor USA
810.0532



x1

12V Power
Adaptor AUS
810.0533

Exploded Assembly

DE Montage – Explosionsansicht

FR Assemblage éclaté

NL Exploded view tekening

IT Assemblaggio esploso

ES Vista detallada del montaje

SE Montering översikt

DK Monteringsoversigt

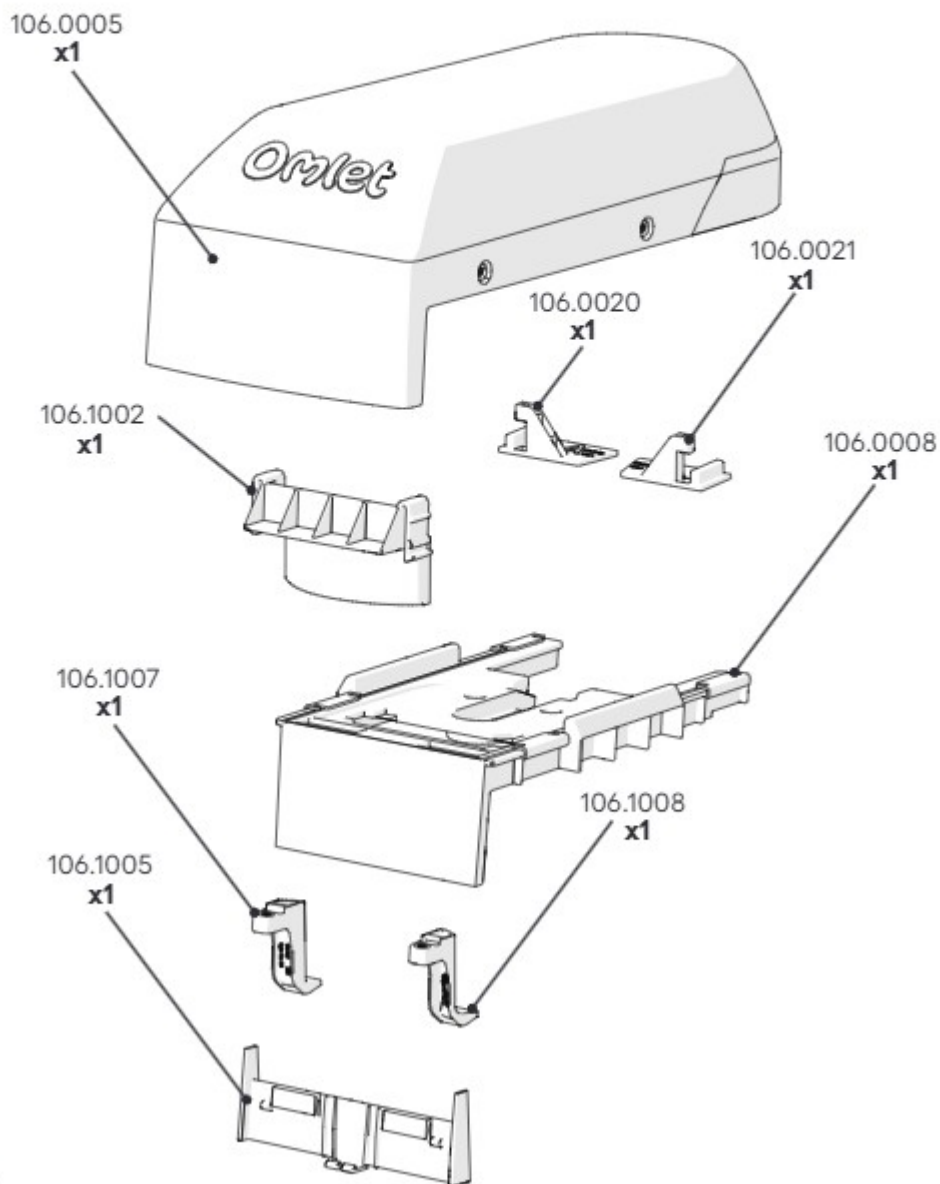

Exploded Assembly - Control Panel (107.0014)

DE Montage - Explosionsansicht - Control Panel (107.0014)

FR Assemblage éclaté - Control Panel (107.0014)

NL Exploded view tekening - Control Panel (107.0014)

IT Assemblaggio esploso - Control Panel (107.0014)

ES Vista detallada del montaje - Control Panel (107.0014)

SE Montering översikt - Control Panel (107.0014)

DK Monteringsoversigt - Control Panel (107.0014)

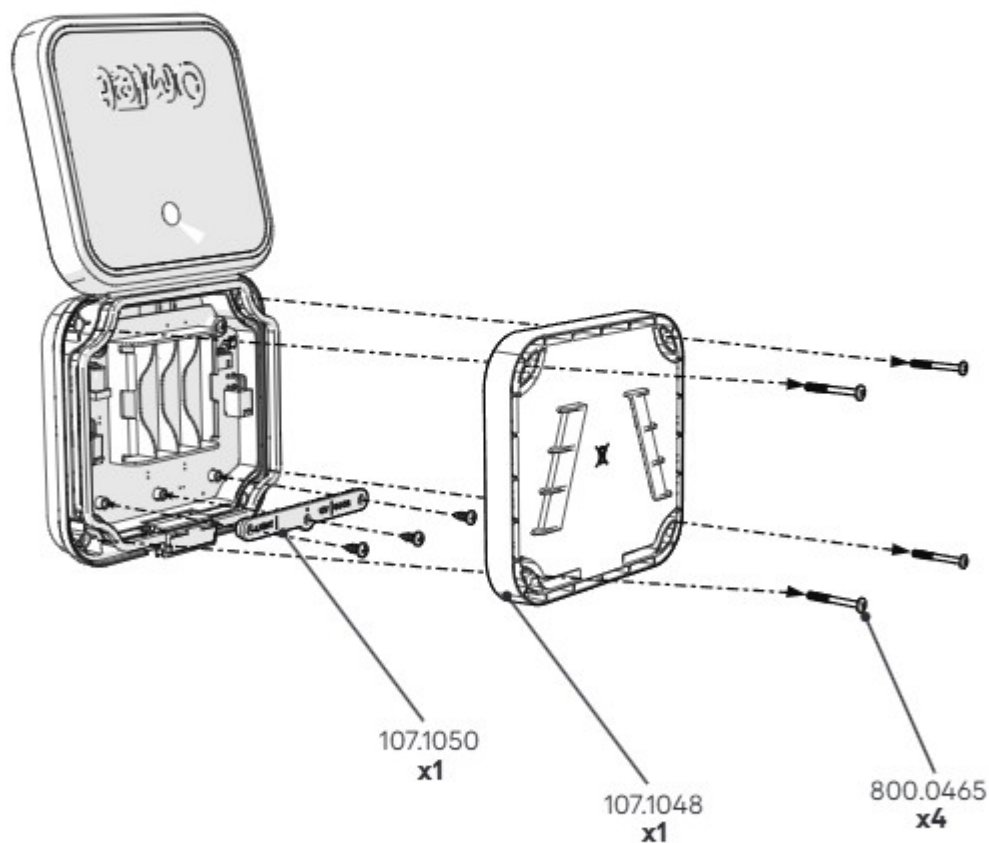

What coop are you attaching your Smart Rotary Eglu AutoDoor (106.0001) to?

DE An welchen Stall befestigen Sie Ihre **Smart Rotary Eglu AutoDoor (106.0001)**?

FR À quel poulailler attachez-vous votre **Smart Rotary Eglu AutoDoor (106.0001)** ?

NL Aan welk hok bevestigt u uw **Smart Rotary Eglu AutoDoor (106.0001)**?

IT A quale coop stai collegando il tuo **Smart Rotary Eglu AutoDoor (106.0001)**?

ES ¿A qué cooperativa vas a conectar tu **Smart Rotary Eglu AutoDoor (106.0001)**?

SE Vilken coop kopplar du din **Smart Rotary Eglu AutoDoor (106.0001)** till?

DK Hvilket coop knytter du din **Smart Rotary Eglu AutoDoor (106.0001)** til?

Eglu Go



Eglu Cube Mk2



Eglu Pro

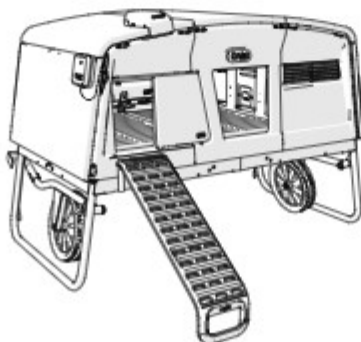

Attaching your Smart Rotary Eglu AutoDoor to an Eglu Go.

DE Die Befestigung der intelligenten, drehbaren Eglu Autodoor an einem Eglu Go.

FR Fixation de votre Porte Automatique intelligente rotative Eglu à un poulailler Eglu Go.

NL De Slimme, roterende Eglu Autodoor bevestigen aan een Eglu Go.

IT Collegare la Smart Autodoor girevole Eglu a un pollaio Eglu Go.

ES Cómo conectar su puerta automática inteligente giratoria a un Eglu Go.

SE Så montera du din smarta Autodörr till Eglu-hönshus på en Eglu Go.

DK Fastgørelse af din smarte, roterende Eglu AutoDoor til en Eglu Go.

1

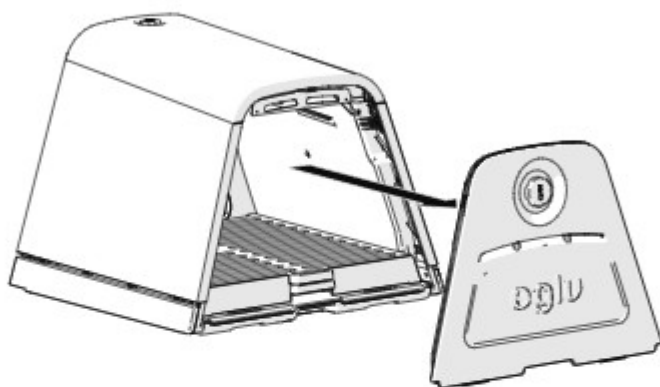

Optional: You can also remove the roof panel to make Steps 2-5 easier, but it must be replaced before you start Step 8.



- **DE** Optional: Sie können die Dachplatte abnehmen, um die Schritte 2 bis 5 zu vereinfachen. Sie muss aber wieder angebracht werden, bevor Sie mit Schritt 8 beginnen.
- **FR** Facultatif : Si vous le souhaitez, vous pouvez retirer le panneau de toit pour faciliter les étapes 2 à 5, mais vous devez le remettre en place avant de commencer l'étape 8.
- **NL** Optioneel: U kunt het dakpaneel verwijderen om stap 2-5 eenvoudiger te maken, maar deze moet opnieuw bevestigd worden voordat u met stap 8 begint.
- **IT** Facoltativo: Se lo si desidera, è possibile rimuovere il pannello del tetto per facilitare i punti 2-5, ma deve essere sostituito prima di iniziare il punto 8
- **ES** Opcional: Si lo desea, puede retirar el panel del tejado para facilitar los pasos 2-5, pero debe volver a colocarlo antes de iniciar el paso 8.
- **SE** Valfrritt: Du kan också ta bort takpanelen för att göra steg 2-5 enklare, men den måste bytas ut innan du börjar med steg 8.
- **DK** Valgfrit: Du kan også fjerne tagpanelet for at gøre trin 2-5 nemmere, men det skal udskiftes, før du starter Trin 8.

2

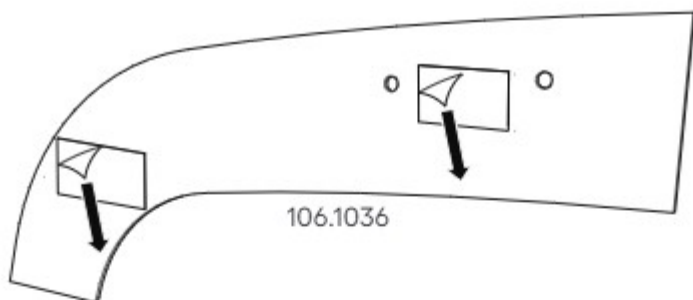

3

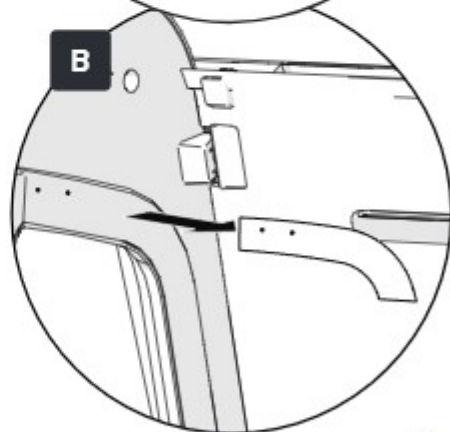
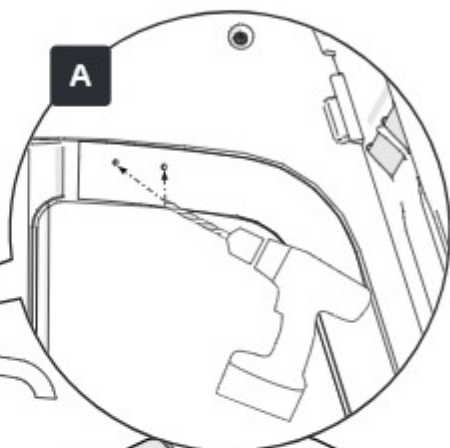
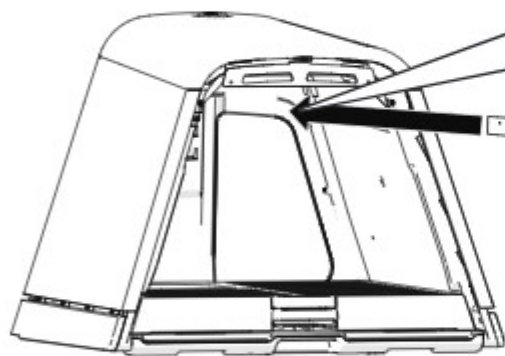

Only drill through the first inside layer of the panel. 

- **DE** Bohren Sie nur durch die erste Innenschicht der Platte.
- **FR** Ne percez que la première couche intérieure du panneau.
- **NL** Boor allen door de eerste binnenlaag van het paneel
- **IT** Forare solo il primo strato interno del pannello.
- **ES** Perfore únicamente la primera capa interior del panel.
- **SE** Borra endast genom det första inre lagret av panelen
- **DK** Bor kun gennem det første indvendige lag af panelet.

4

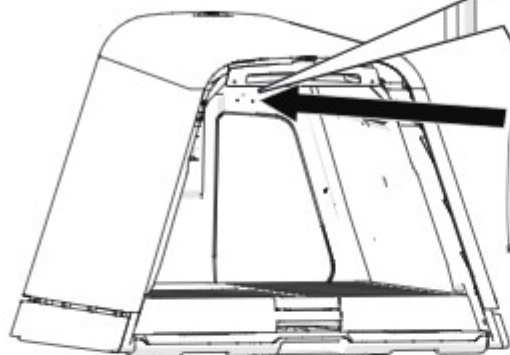
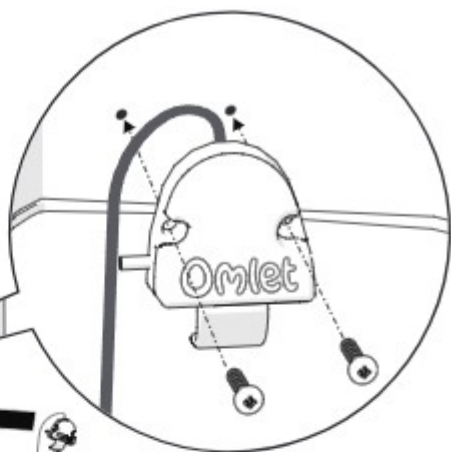

106.0017

5

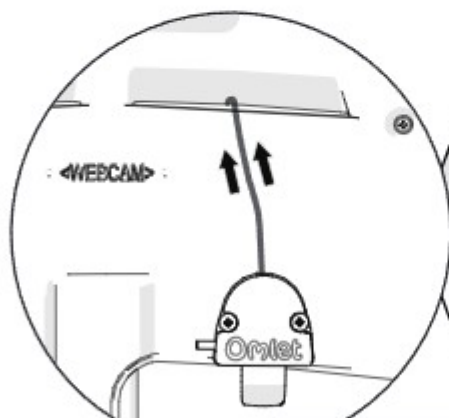
Feed wire through the vent.

- **DE** Führen Sie das Kabel durch die Öffnung.
- **FR** Faites passer le câble par l'ouverture.
- **NL** Leid de kabel door de opening.
- **IT** Far passare il cavo attraverso la ventola
- **ES** Pase el cable por la abertura.
- **SE** Mata sladden genom ventilen.
- **DK** Før ledningen gennem ventilen.



You can now reattach your back panel.



- **DE** Sie können nun die Rückwand wieder anbringen.
- **FR** Vous pouvez maintenant refixer votre panneau arrière.
- **NL** U kunt het achterpaneel nu opnieuw bevestigen.
- **IT** Ora è possibile reinstallare il pannello posteriore.
- **ES** Ahora puede volver a colocar el panel trasero.
- **SE** Du kan nu sätta tillbaka panelen på baksidan.

6

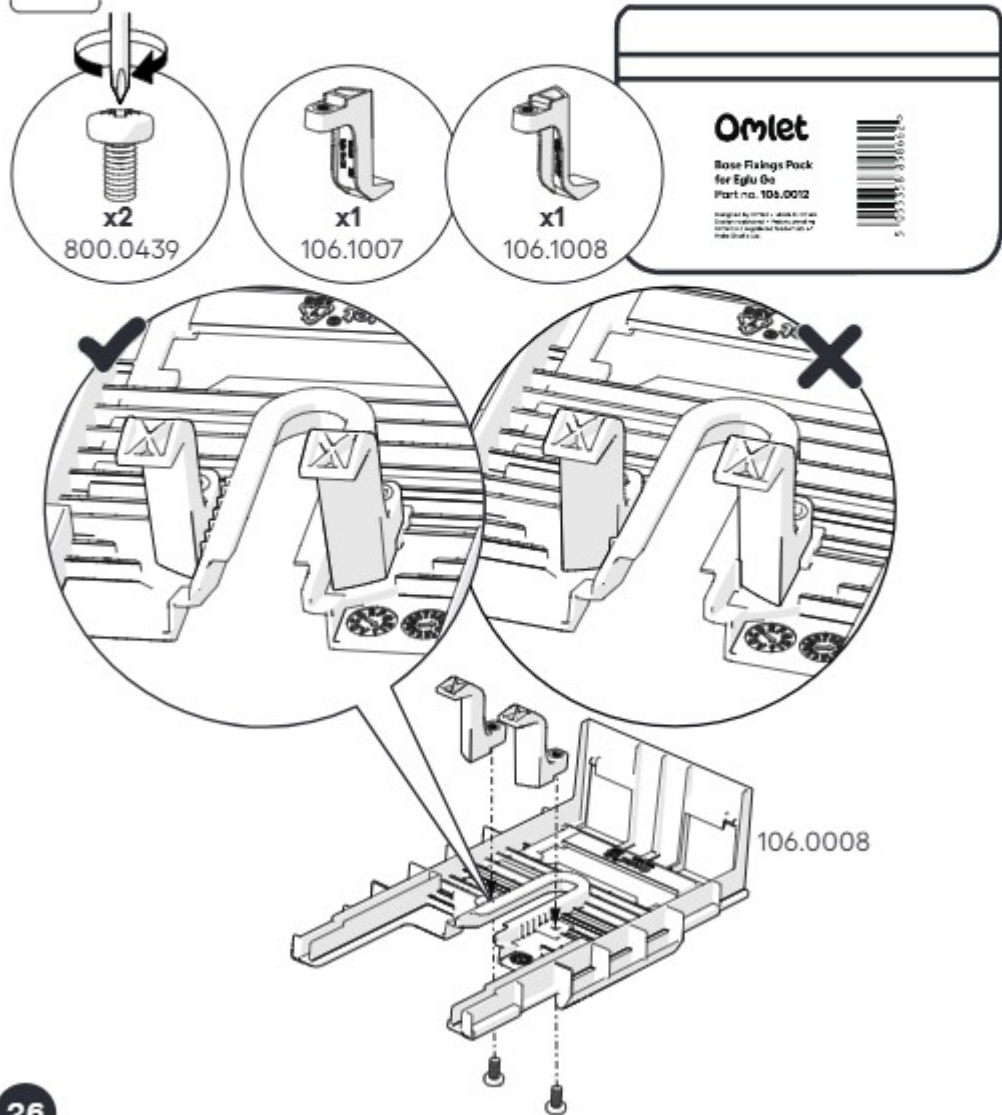

7



x1
106.1005

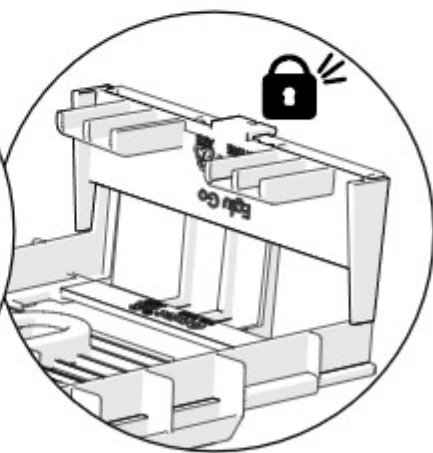
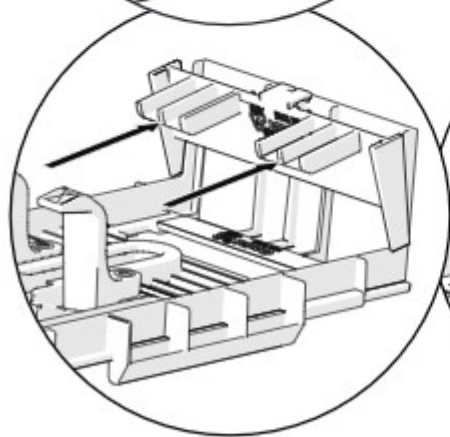
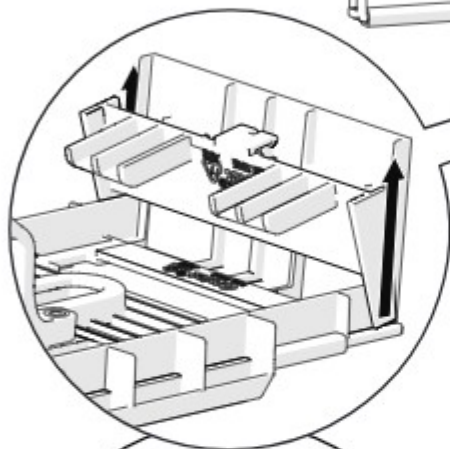
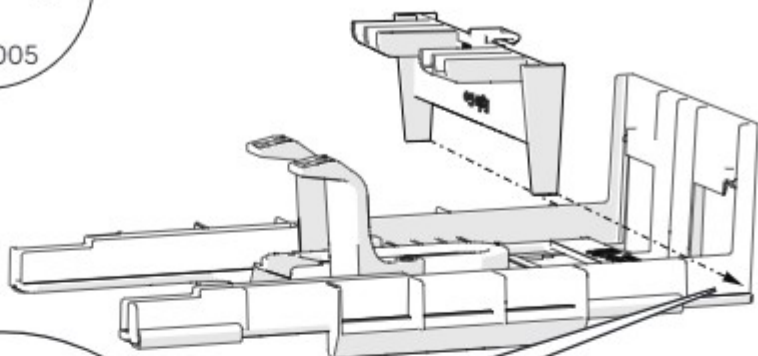

8

Make sure the area around your T-handle is clean and dry so your **Base Supports (106.0020, 106.0021)** can stick to it easily.



DE Stellen Sie sicher, dass der Bereich um den T-Griff sauber und trocken ist, damit die **Base Supports (106.0020, 106.0021)** leicht daran haften können.

FR Assurez-vous que la zone autour de votre poignée en T est propre et sèche afin que votre **Base Supports (106.0020, 106.0021)** puisse adhérer facilement.

NL Zorg dat het gebied rond de T-handgreep schoon en droog is, zodat de **Base Supports (106.0020, 106.0021)** gemakkelijk kan worden bevestigd.

IT Assicurarsi che l'area intorno all'impugnatura a T sia asciutta e pulita in modo che il **Base Supports (106.0020, 106.0021)** possa aderire facilmente.

ES Asegúrese de que la zona alrededor del tirador en T esté limpia y seca para que el **Base Supports (106.0020, 106.0021)** pueda adherirse fácilmente.

SE Se till att området runt ditt T-handtag är rent och torrt så att din **Base Supports (106.0020, 106.0021)** lätt kan fästa vid det.

DK Sørg for, at området omkring dit T-håndtag er rent og tørt, så din **Base Supports (106.0020, 106.0021)** nemt kan klæbe sig fast til det.

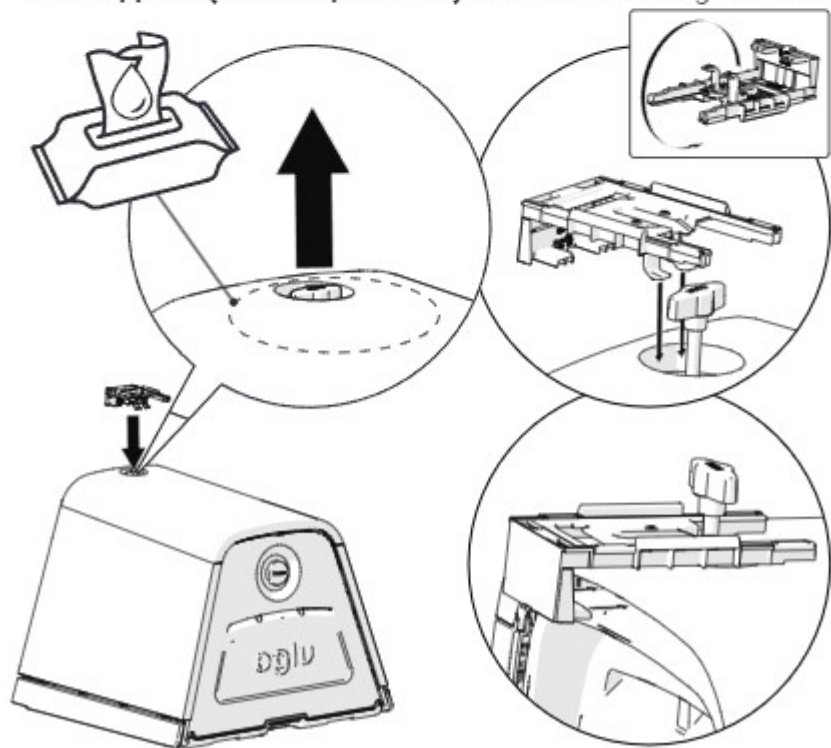

9

Push Base 106.0008 firmly against coop whilst marking out positions of 106.0020 and 106.0021.



DE Drücken Sie die Basis **106.0008** fest gegen den Stall, während Sie die Positionen von **106.0020** und **106.0021** markieren.

FR Appuyez fermement la base **106.0008** contre le poulailler tout en marquant les positions des pièces **106.0020** et **106.0021**.

NL Druk basis **106.0008** stevig tegen het hok terwijl je de posities van **106.0020** en **106.0021** markeert.

IT Spingere con fermezza la base **106.0008** contro il pollaio, contrassegnando al contempo le posizioni di **106.0020** e **106.0021**.

ES Empuje la base **106.0008** firmemente contra el gallinero mientras marca las posiciones de **106.0020** y **106.0021**.

SE Håll fast basen **106.0008** mot höns huset när du markerar positionerna för **106.0020** och **106.0021**.

DK Skub base **106.0008** fast mod kabinettet, mens du markerer positionerne for **106.0020** og **106.0021**.

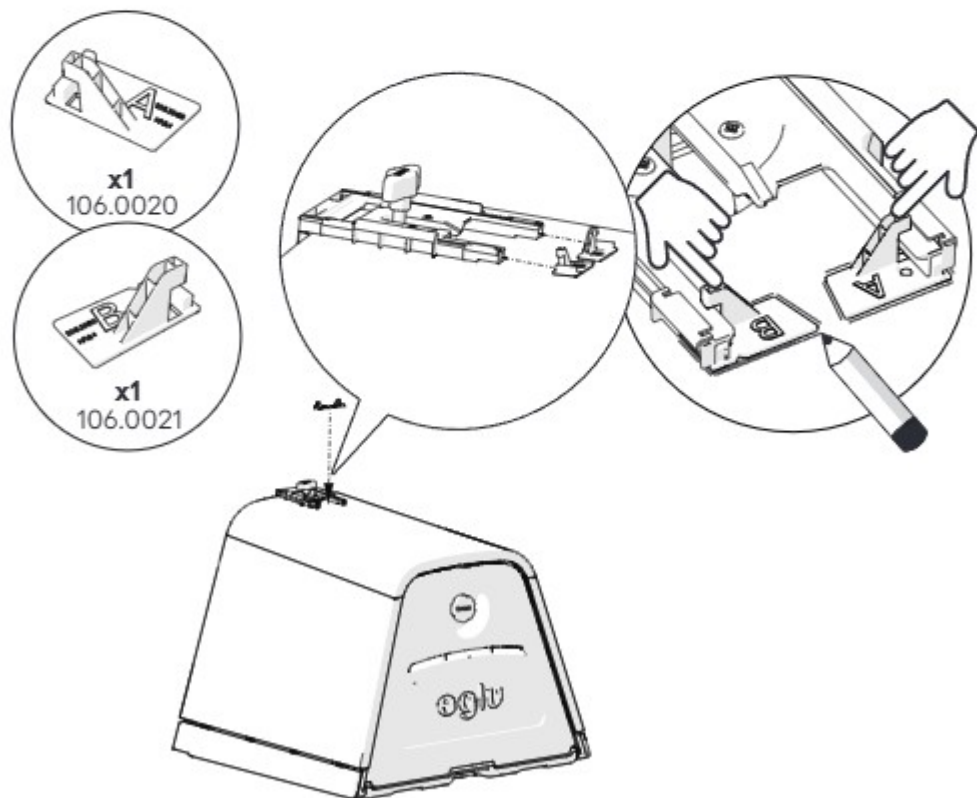

10

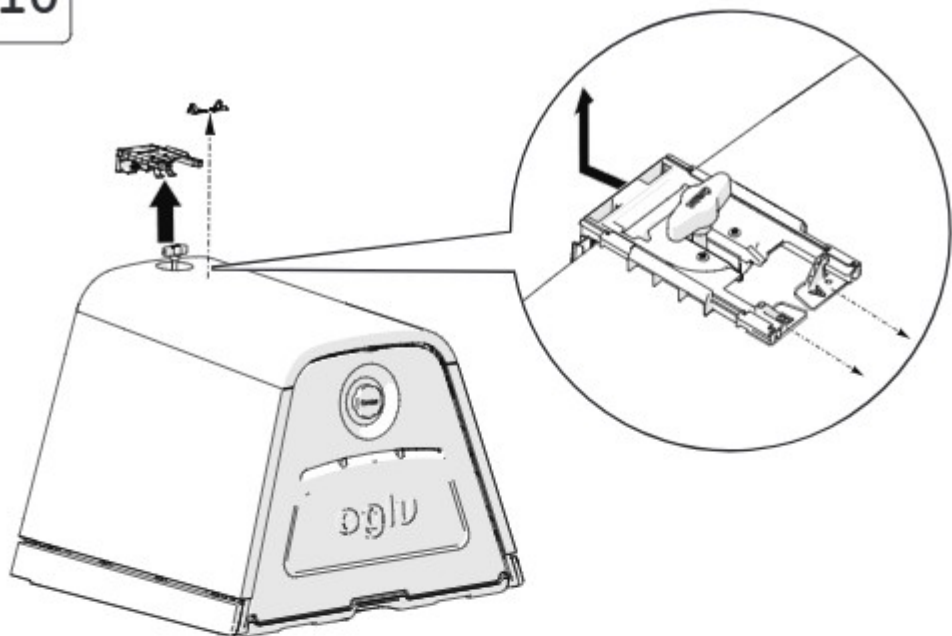

11

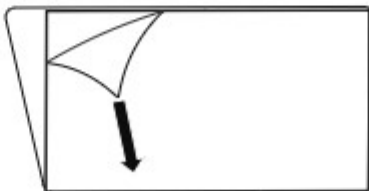

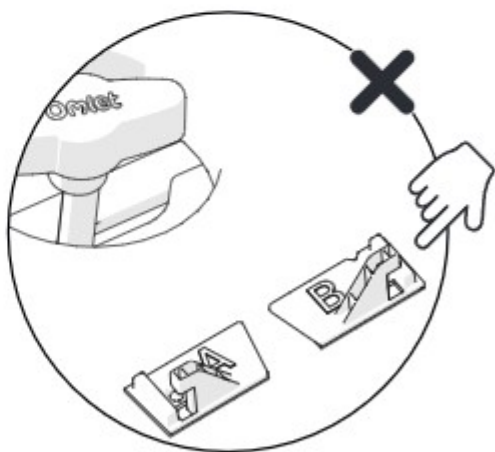
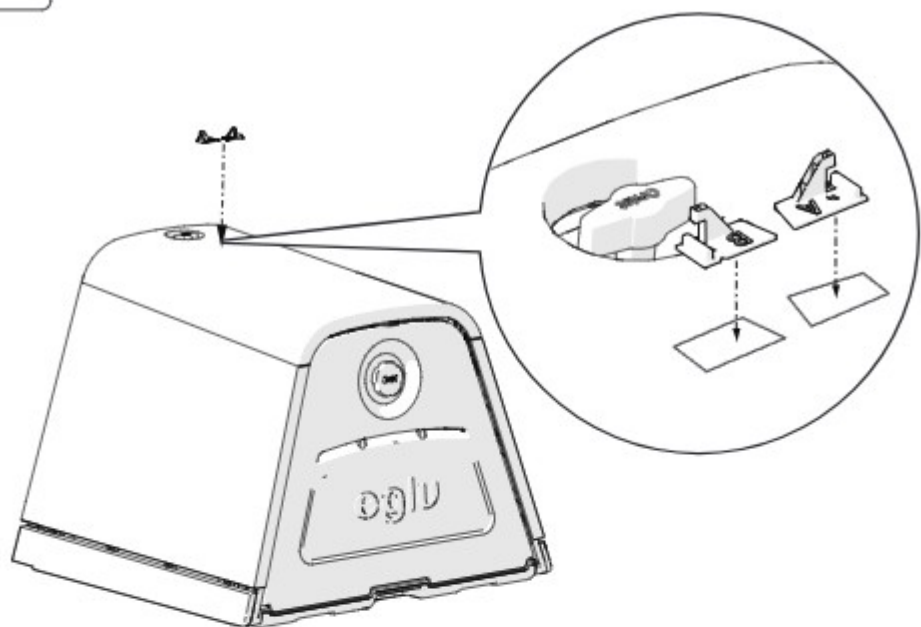

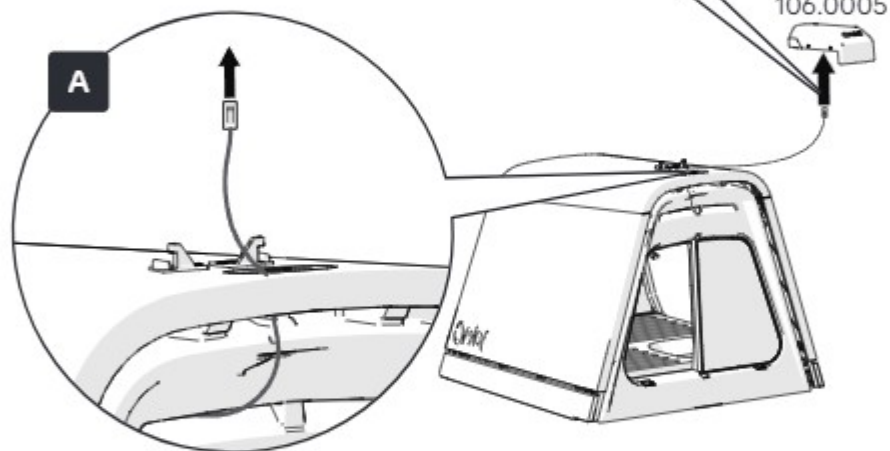
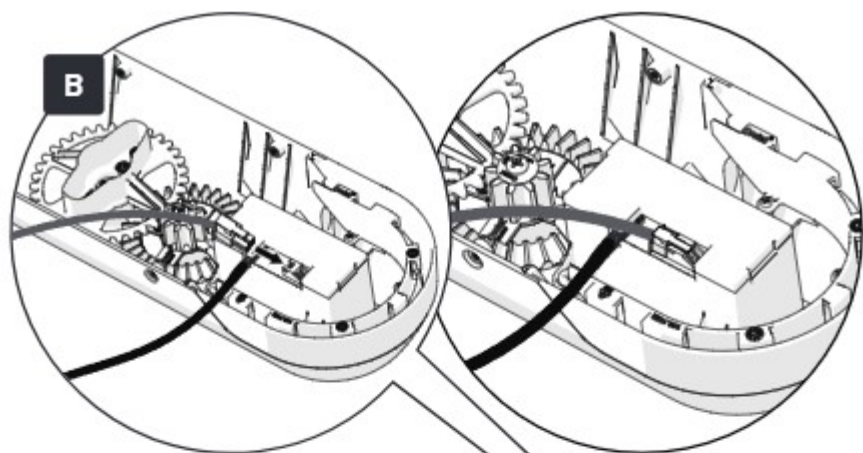

13

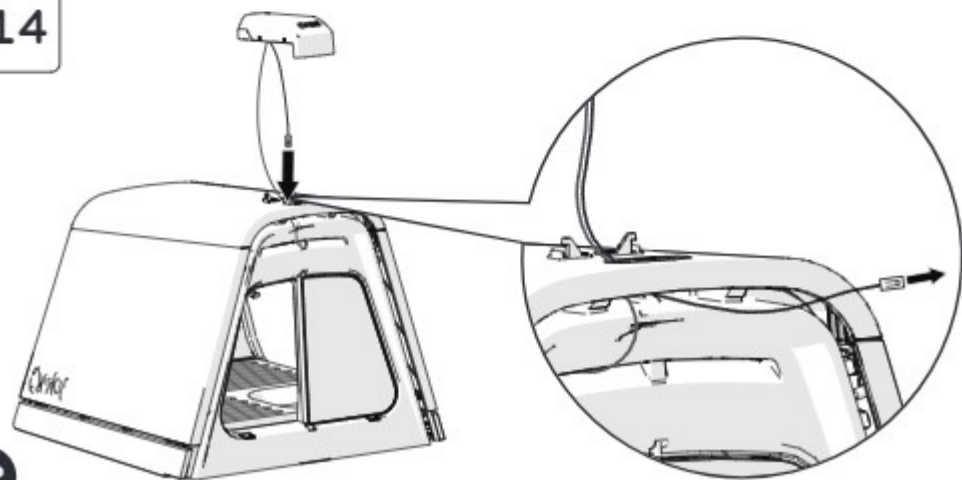

14

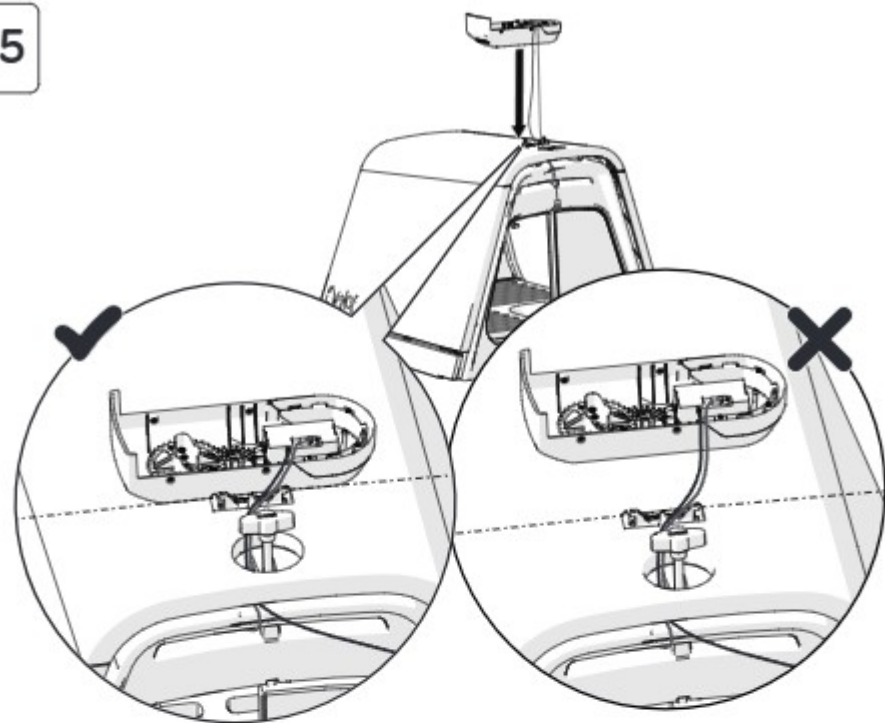



It is very important to position the gear case (106.0005) correctly on top of your coop to ensure wires will be the correct length during the next step. 

- **DE** Es ist äußerst wichtig, das Getriebegehäuse (106.0005) richtig auf dem Stall zu positionieren, damit die Kabel beim nächsten Schritt die richtige Länge haben.
- **FR** Il est très important de positionner correctement le boîtier d'engrenages (106.0005) sur le dessus de votre poulailler pour que les câbles soient de la bonne longueur lors de l'étape suivante.
- **NL** Het is uiterst belangrijk dat de gear case (106.0005) correct op het hok te plaatsen, zodat de kabels de juiste lengte hebben tijdens de volgende stap.
- **IT** È molto importante posizionare la centralina (106.0005) nella maniera corretta sul pollaio in modo che i cavi siano della lunghezza adeguata nello step successivo.
- **ES** Es muy importante colocar correctamente la caja de engranajes (106.0005) en la parte superior del gallinero para que los cables tengan la longitud adecuada para el siguiente paso.
- **SE** Det är mycket viktigt att placera gear case (106.0005) korrekt ovanpå ditt höns hus för att se till att kablarna har rätt längd under nästa steg.
- **DK** Det er meget vigtigt at placere gearkassen (106.0005) korrekt oven på dit høns hus for at sikre, at ledningerne har den korrekte længde under næste trin.

16

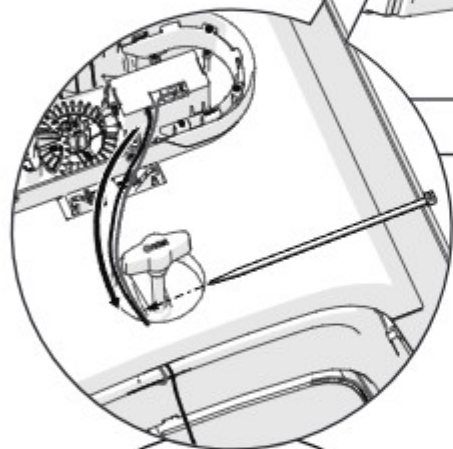
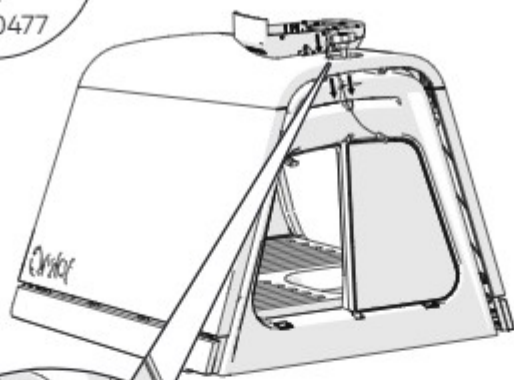

Pull wires tight.

- **DE** Ziehen Sie die Kabel fest an.
- **FR** Tirez sur les câbles pour les serrer.
- **NL** Trek de kabels strak aan.
- **IT** Tirare i cavi per stringerli.
- **ES** Tense los cables.
- **SE** Dra åt kablarna.
- **DK** Træk ledningerne stramt.

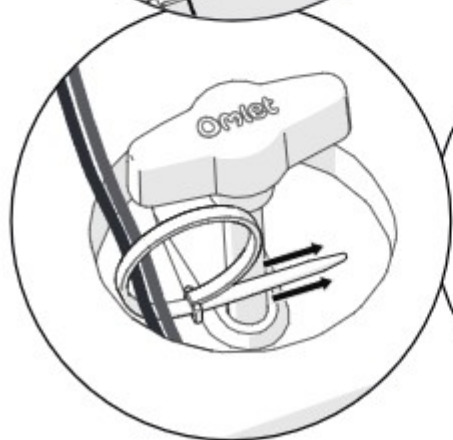

17

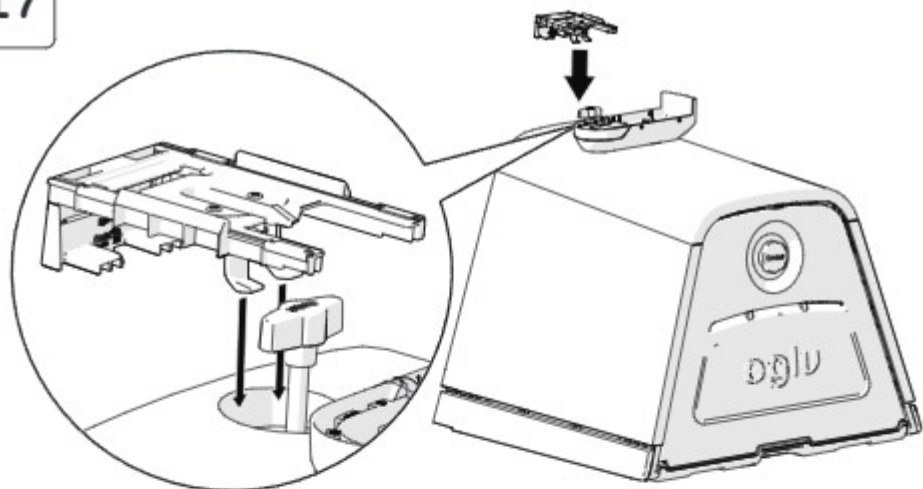

18

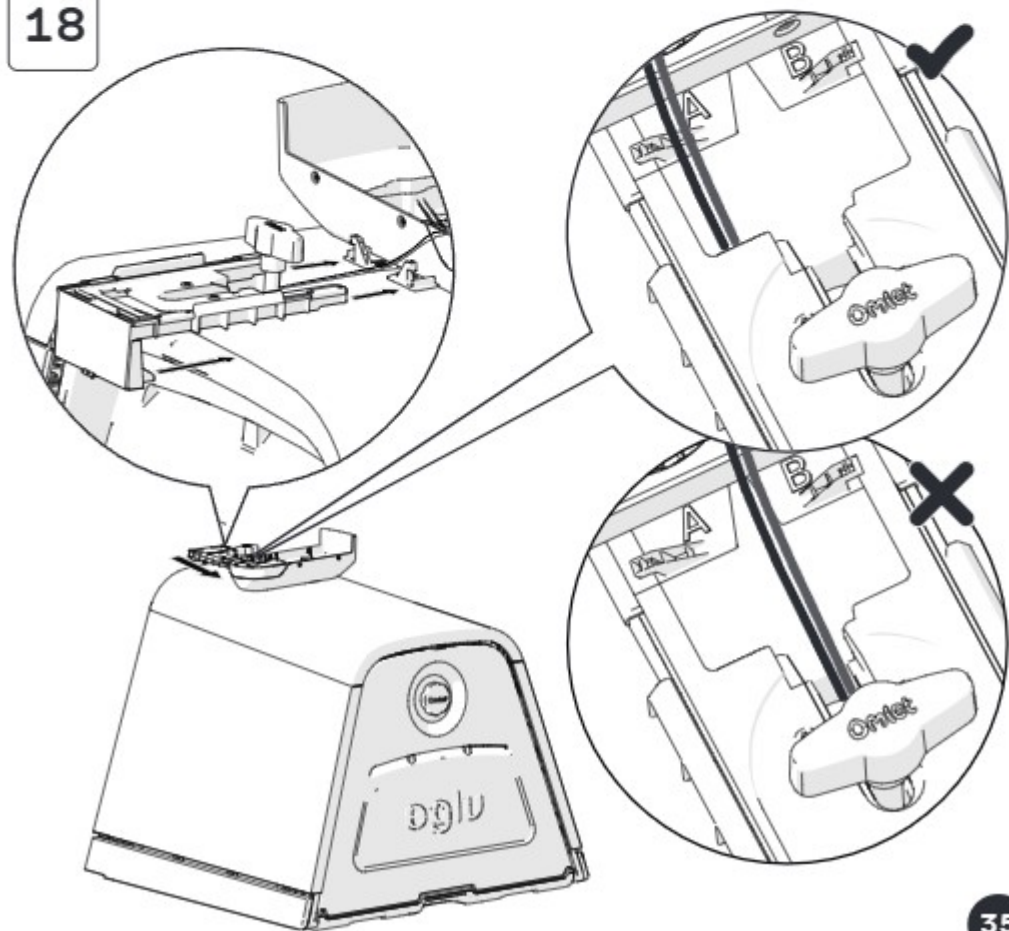

19

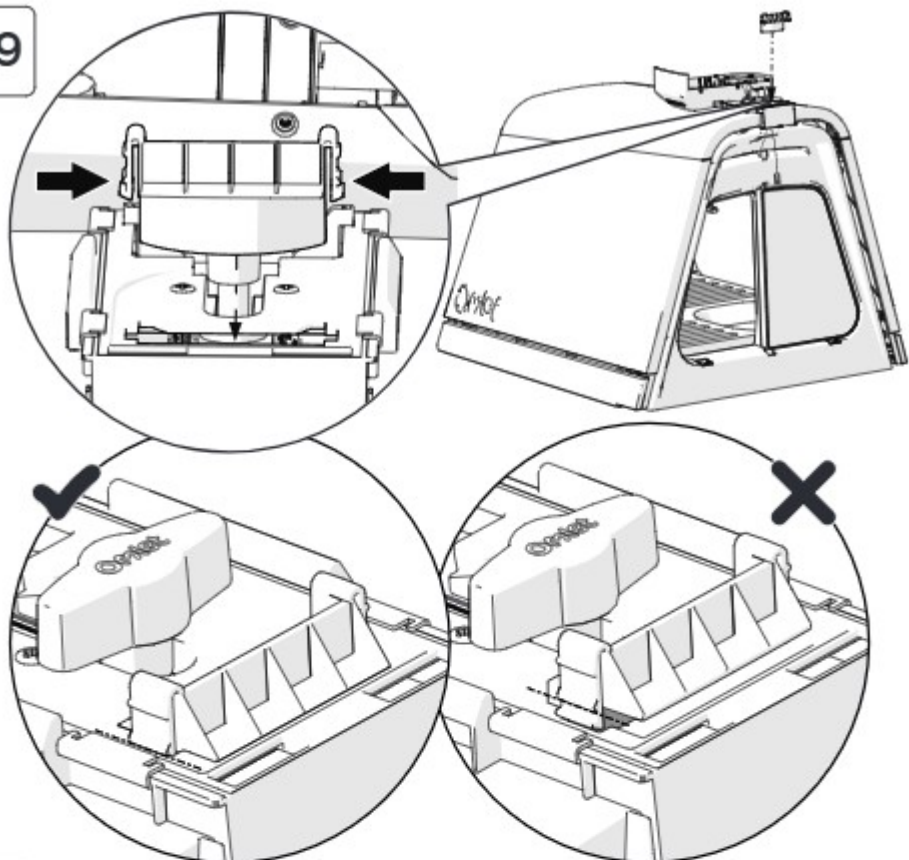

20

Pull wires tight.



- **DE** Ziehen Sie die Kabel fest an.
- **FR** Tirez sur les câbles pour les serrer.
- **NL** Trek de kabels strak aan.
- **IT** Tirare i cavi per stringerli.
- **ES** Tense los cables.
- **SE** Dra åt kablarna.
- **DK** Træk ledningerne stramt.

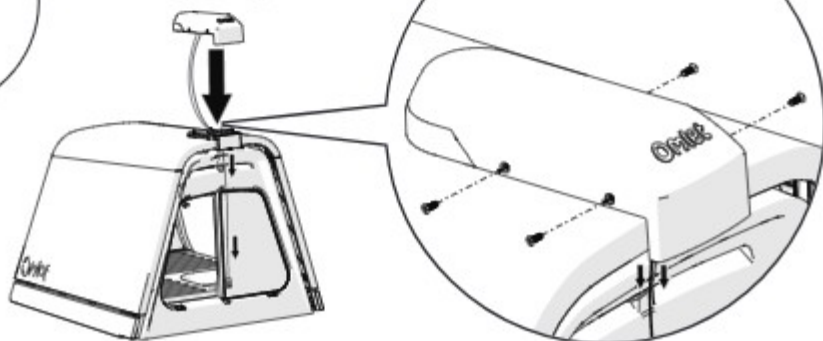

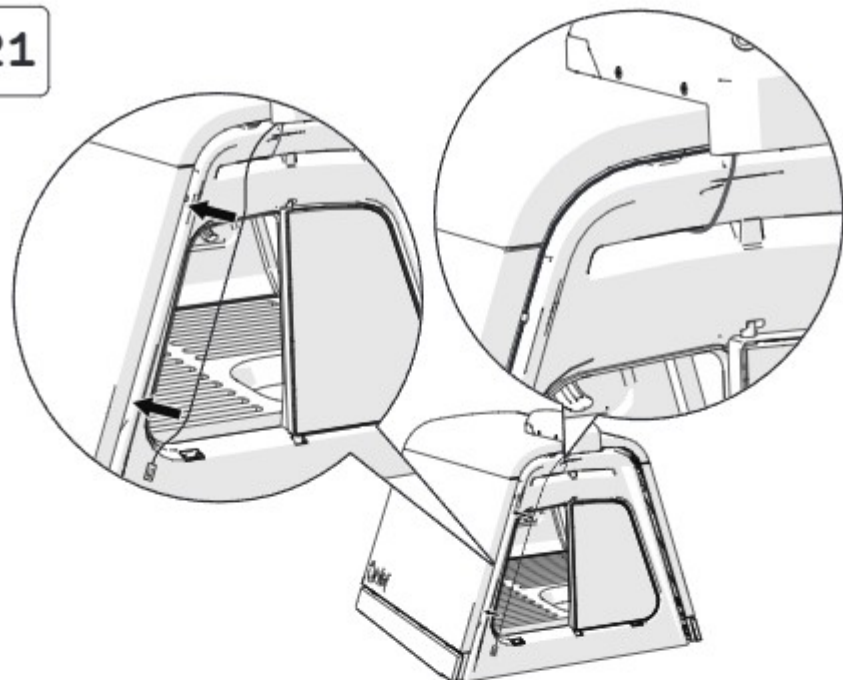

If you are attaching your coop to a Walk In Run Connection Kit.

DE Wenn Sie an Ihrem Stall einen Verbindungsbausatz für das Walk In Run – Begehbare Hühnergehege anbringen.

FR Si vous fixez votre poulailler à un kit de raccordement pour Grand Enclos.

NL Als u het kippenhok koppelt met een Verbindingsset voor Inloopren.

IT Se il pollaio viene collegato al kit di collegamento del recinto Walk-In.

ES Si va a acoplar su gallinero a un kit de conexión para recintos Walk In.

SE Om du ansluter ditt höns hus till ett sammanfogningskit för walk in-gårdar.

DK Hvis du fastgør dit hønses hus til et forbindelsessæt til en walk-in løbegård.



To Assemble the Control Panel (107.0014)

DE Zur Montage der **Steuereinheit (107.0014)**

FR Assemblage du **boîtier de contrôle (107.0014)**

NL Om het **Control Panel (107.0014)** te monteren

IT Per assemblare il **pannello di comando (107.0014)**

ES Ensamblar el **panel de control (107.0014)**

SE Montera **kontrollpanelen (107.0014)**

DK For at montere **kontrolpanelet (107.0014)**



Attaching your Smart Rotary Eglu Autodoor to an Eglu Cube.

DE Die Befestigung der intelligenten, drehbaren Eglu Autodoor an einem Eglu Cube.

FR Fixation de votre Porte Automatique intelligente rotative Eglu à un poulailler Eglu Cube.

NL De Slimme, roterende Eglu Autodoor bevestigen aan een Eglu Cube.

IT Collegare la Smart Autodoor girevole Eglu a un pollaio Eglu Cube.

ES Cómo conectar su puerta automática inteligente giratoria a un Eglu Cube.

SE Så montera du din smarta Autodörr till Eglu-hönshus på en Eglu Cube.

DK Fastgørelse af din smarte, roterende Eglu AutoDoor til en Eglu Cube.

22 Keep the Parts safe until Step 28.



- **DE** Legen Sie die Teile bis Schritt 28 beiseite.
- **FR** Mettez ces pièces de côté pour l'étape 28.
- **NL** Leg de onderdelen opzij tot stap 28.
- **IT** Mettere da parte fino al Punto 28.
- **ES** Guarde la pieza hasta el paso 28.
- **SE** Lägg undan delarna till steg 28.
- **DK** Læg delene til side indtil trin 28.

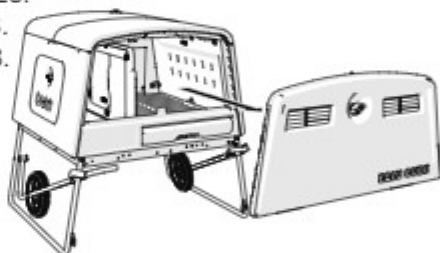

23 Keep the part safe until Step 28.



- **DE** Legen Sie das Teile bis Schritt 28 beiseite.
- **FR** Mettez cette pièce de côté pour l'étape 28.
- **NL** Leg het onderdeel opzij tot stap 28.
- **IT** Mettere da parte fino al Punto 28.
- **ES** Lägg undan delen till steg 28.
- **SE** Lägg undan delen till steg 28.
- **DK** Læg delen til side indtil trin 28.



24

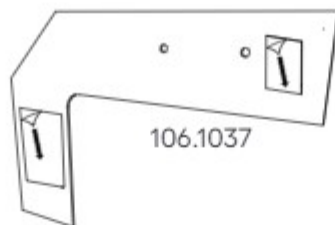

25

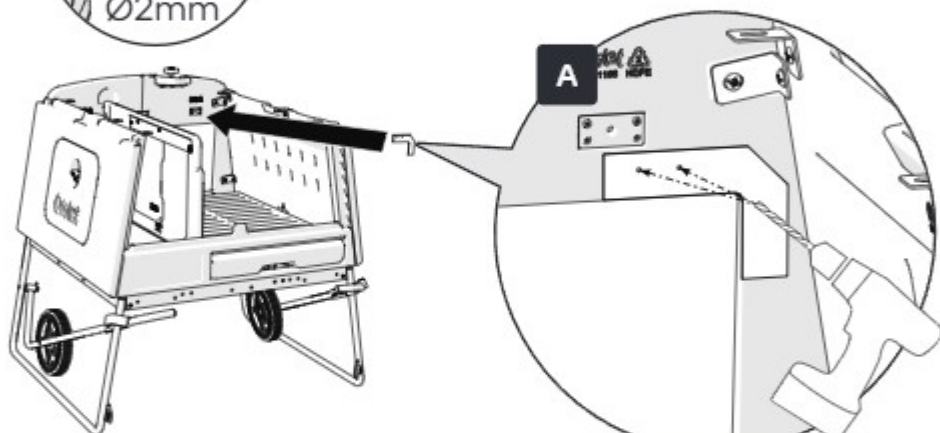

Only drill through the first inside layer of the panel.



- **DE** Bohren Sie nur durch die erste Innenschicht der Platte.
- **FR** Ne percez que la première couche intérieure du panneau.
- **NL** Boor allen door de eerste binnenlaag van het paneel.
- **IT** Forare solo il primo strato interno del pannello.
- **ES** Perfore únicamente la primera capa interior del panel.
- **SE** Borra endast genom det första inre lagret av panelen.
- **DK** Bor kun gennem det første indvendige lag af panelet.

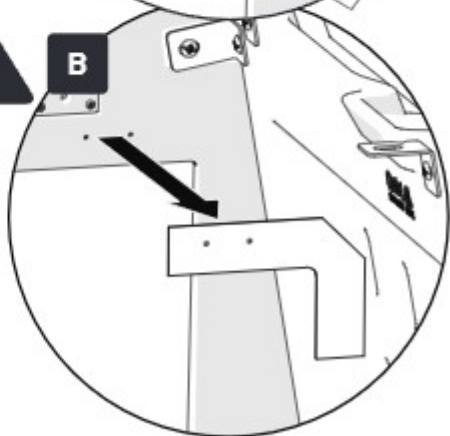

26

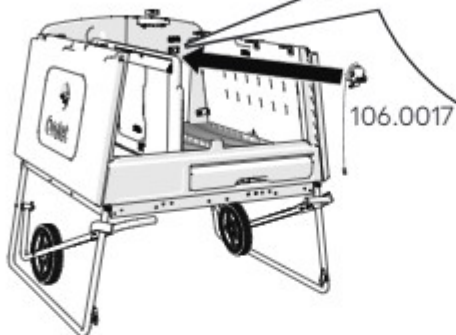
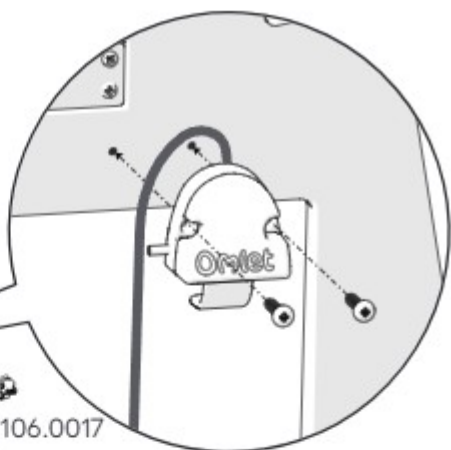

27

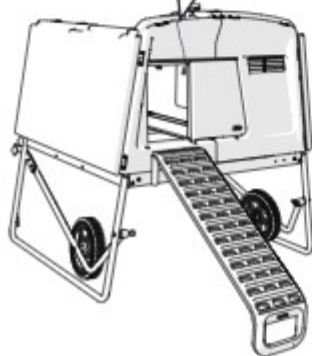
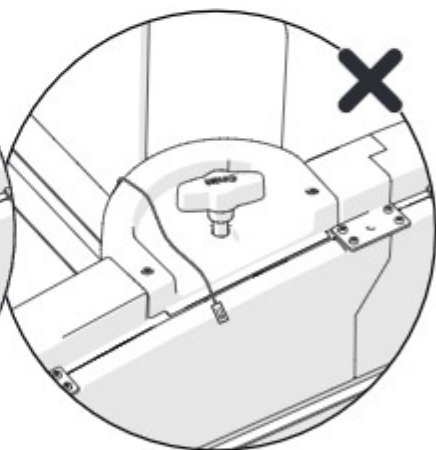
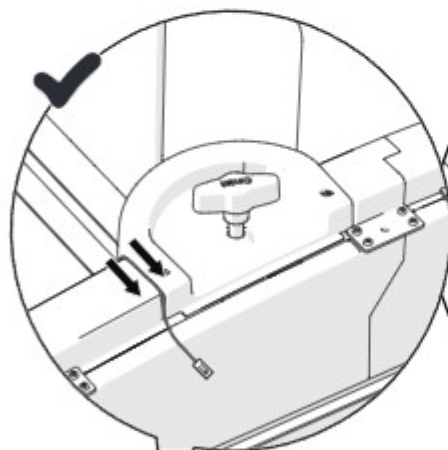

28



29

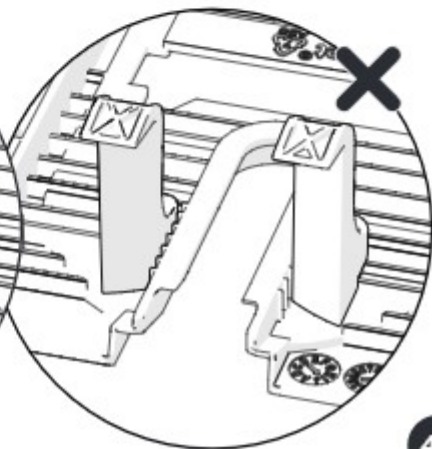
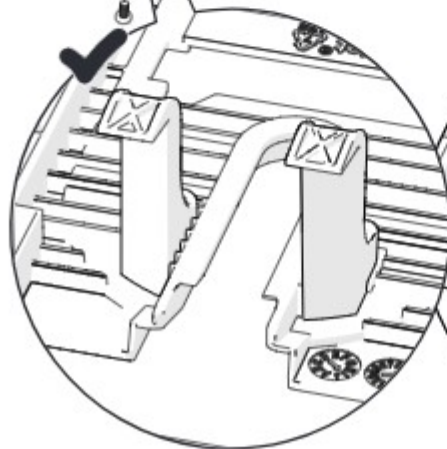
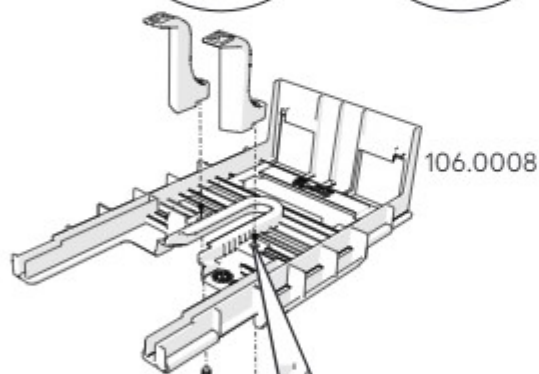
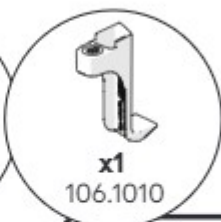

30

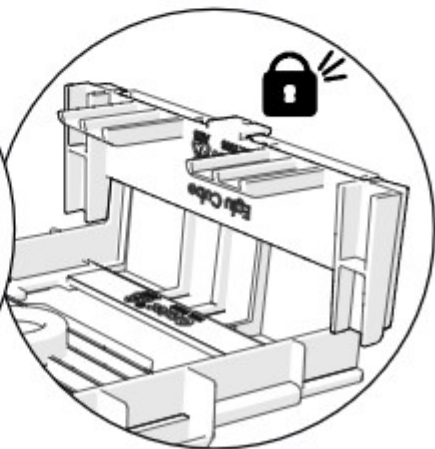
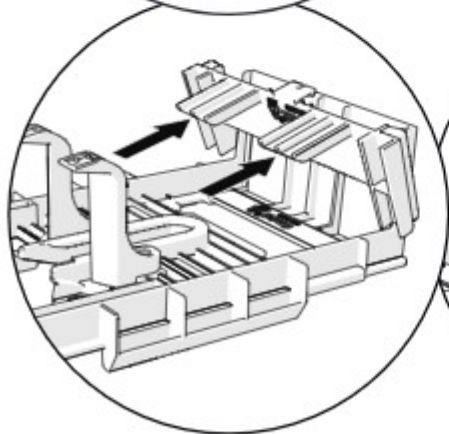
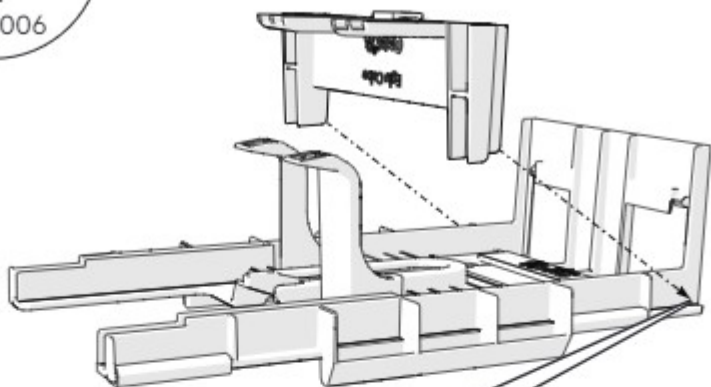
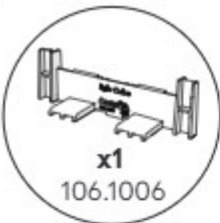

31

Make sure the area around your T-handle is clean and dry so your Base Supports (106.0020, 106.0021) can stick to it easily.



DE Stellen Sie sicher, dass der Bereich um den T-Griff sauber und trocken ist, damit die **Base Supports (106.0020, 106.0021)** leicht daran haften können.

FR Assurez-vous que la zone autour de votre poignée en T est propre et sèche afin que votre **Base Supports (106.0020, 106.0021)** puisse adhérer facilement.

NL Zorg dat het gebied rond de T-handgreep schoon en droog is, zodat de **Base Supports (106.0020, 106.0021)** gemakkelijk kan worden bevestigd.

IT Assicurarsi che l'area intorno all'impugnatura a T sia asciutta e pulita in modo che il **Base Supports (106.0020, 106.0021)** possa aderire facilmente.

ES Asegúrese de que la zona alrededor del tirador en T esté limpia y seca para que el **Base Supports (106.0020, 106.0021)** pueda adherirse fácilmente.

SE Se till att området runt ditt T-handtag är rent och torrt så att din **Base Supports (106.0020, 106.0021)** lätt kan fästa vid det.

DK Sørg for, at området omkring dit T-håndtag er rent og tørt, så din **Base Supports (106.0020, 106.0021)** nemt kan klæbe sig fast til det.

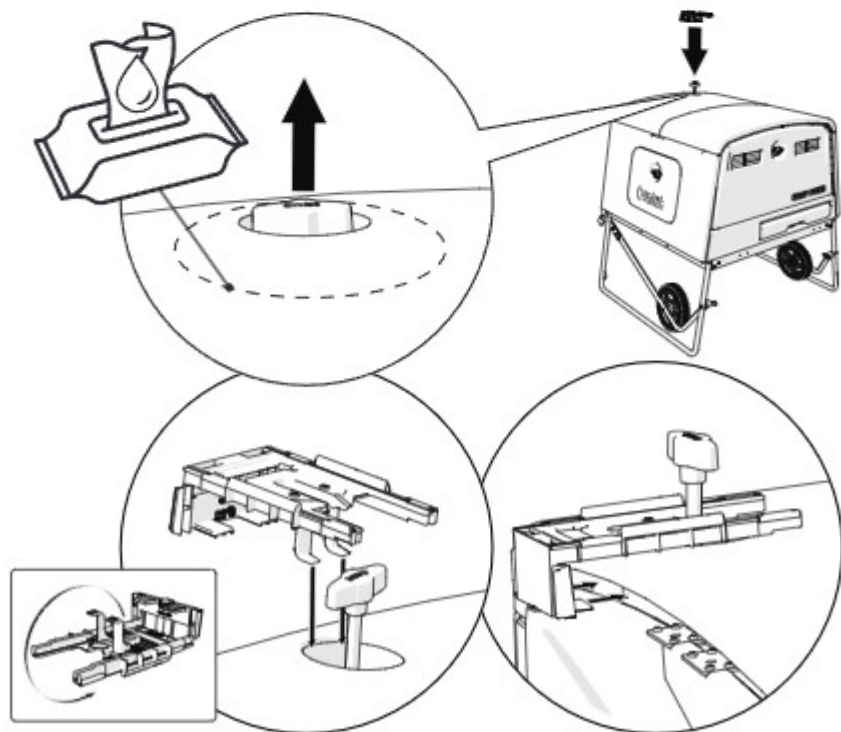

Push Base 106.0008 firmly against coop whilst marking out positions of 106.0020 and 106.0021.



DE Drücken Sie die Basis **106.0008** fest gegen den Stall, während Sie die Positionen von **106.0020** und **106.0021** markieren.

FR Appuyez fermement la base **106.0008** contre le poulailler tout en marquant les positions des pièces **106.0020** et **106.0021**.

NL Druk basis **106.0008** stevig tegen het hok terwijl je de posities van **106.0020** en **106.0021** markeert.

IT Spingere con fermezza la base **106.0008** contro il pollaio, contrassegnando al contempo le posizioni di **106.0020** e **106.0021**.

ES Empuje la base **106.0008** firmemente contra el gallinero mientras marca las posiciones de **106.0020** y **106.0021**.

SE Håll fast basen **106.0008** mot höns huset när du markerar positionerna för **106.0020** och **106.0021**.

DK Skub base **106.0008** fast mod kabinettet, mens du markerer positionerne for **106.0020** og **106.0021**.

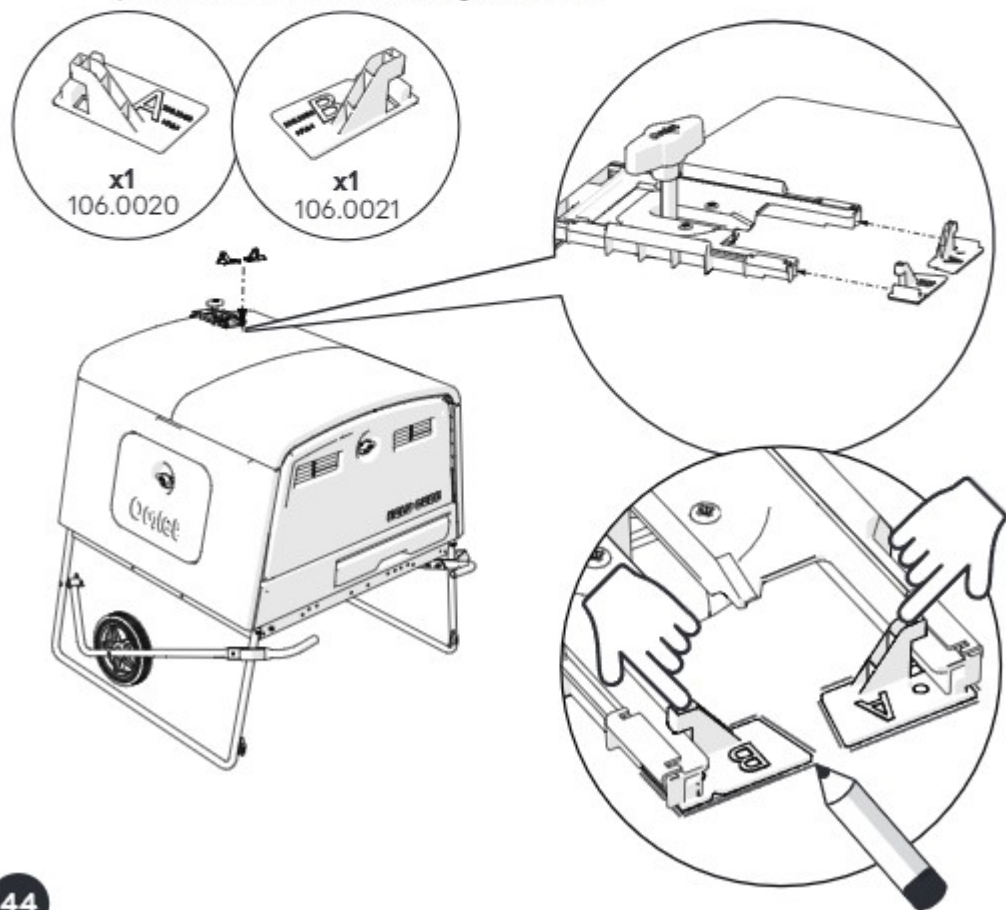

33

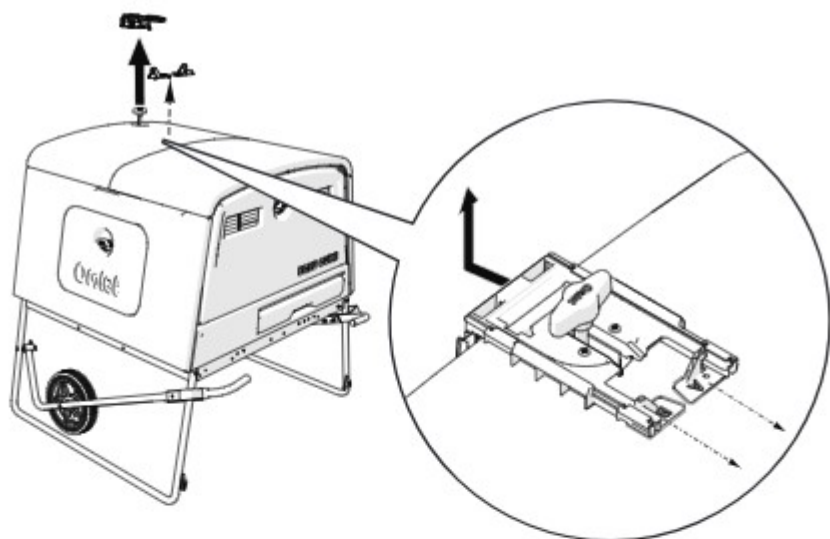

34

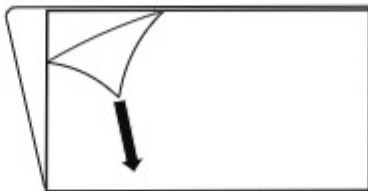
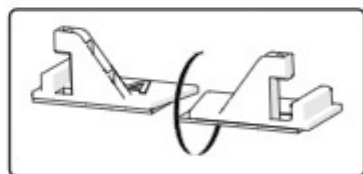

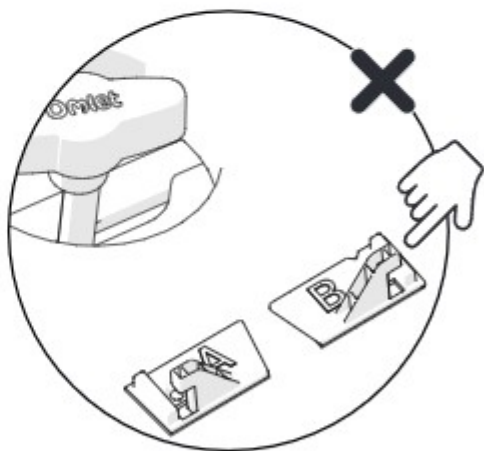
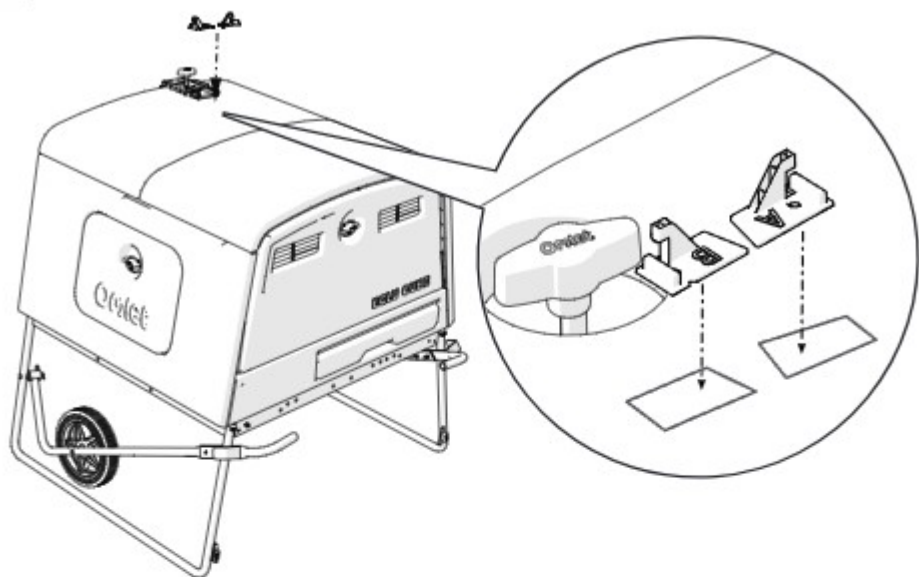

36

B

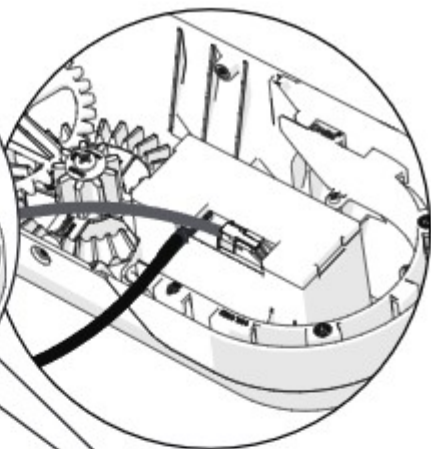
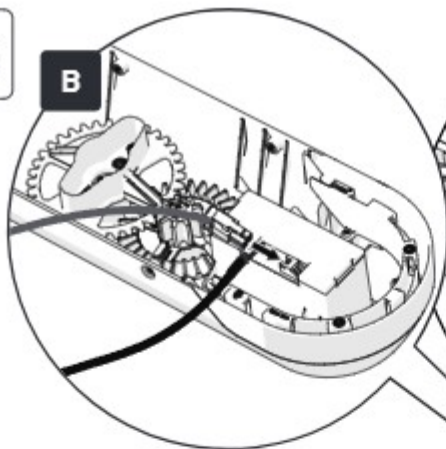

A

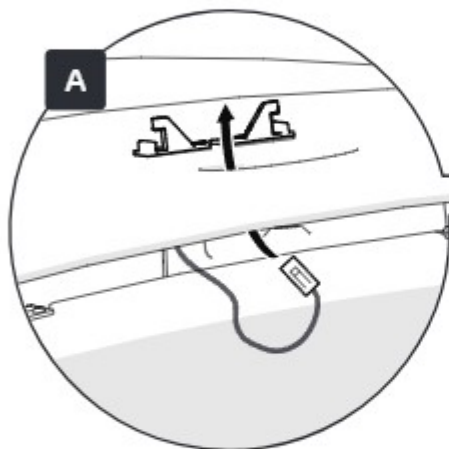

106.0005

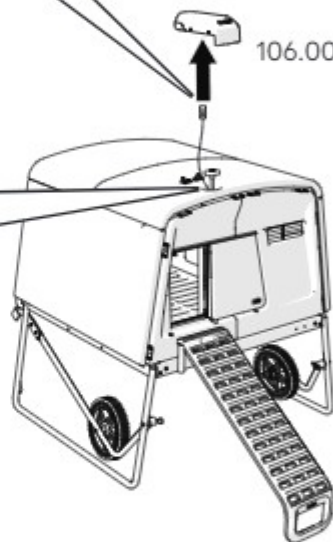

37

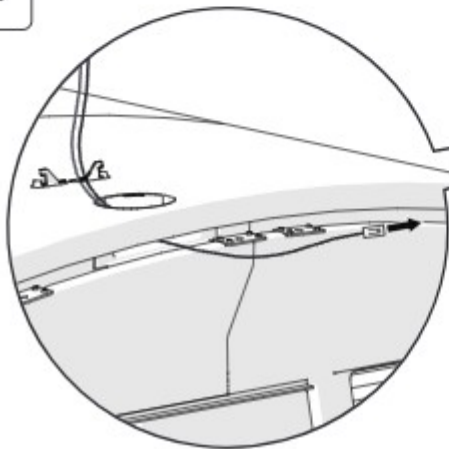

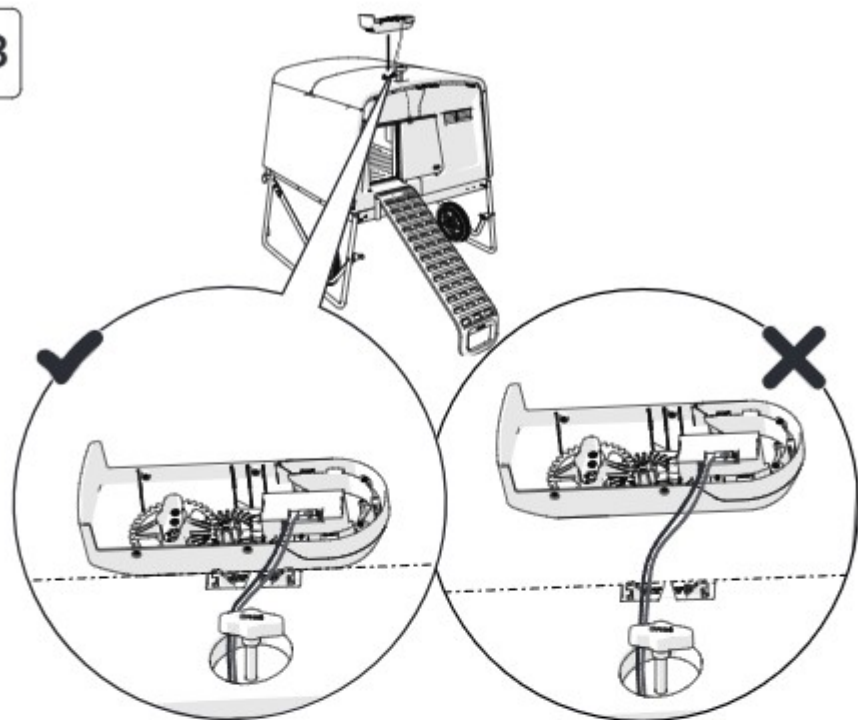

It is very important to position the gear case (106.0005) correctly on top of your coop to ensure wires will be the correct length during the next step. 

- **DE** Es ist äußerst wichtig, das Getriebegehäuse (106.0005) richtig auf dem Stall zu positionieren, damit die Kabel beim nächsten Schritt die richtige Länge haben.
- **FR** Il est très important de positionner correctement le boîtier d'engrenages (106.0005) sur le dessus de votre poulailler pour que les câbles soient de la bonne longueur lors de l'étape suivante.
- **NL** Het is uiterst belangrijk dat de gear case (106.0005) correct op het hok te plaatsen, zodat de kabels de juiste lengte hebben tijdens de volgende stap.
- **IT** È molto importante posizionare la centralina (106.0005) nella maniera corretta sul pollaio in modo che i cavi siano della lunghezza adeguata nello step successivo.
- **ES** Es muy importante colocar correctamente la caja de engranajes (106.0005) en la parte superior del gallinero para que los cables tengan la longitud adecuada para el siguiente paso.
- **SE** Det är mycket viktigt att placera gear case (106.0005) korrekt ovanpå ditt höns hus för att se till att kablarna har rätt längd under nästa steg.
- **DK** Det er meget vigtigt at placere gearkassen (106.0005) korrekt oven på dit hønsehus for at sikre, at ledningerne har den korrekte længde under næste trin.

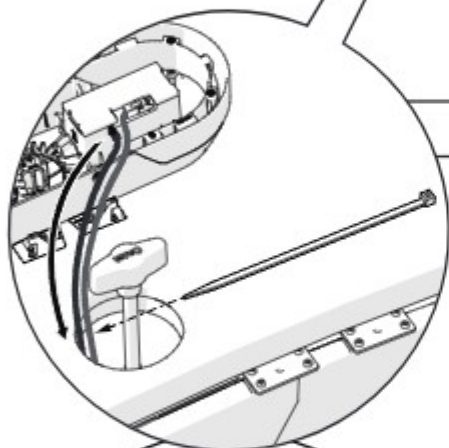
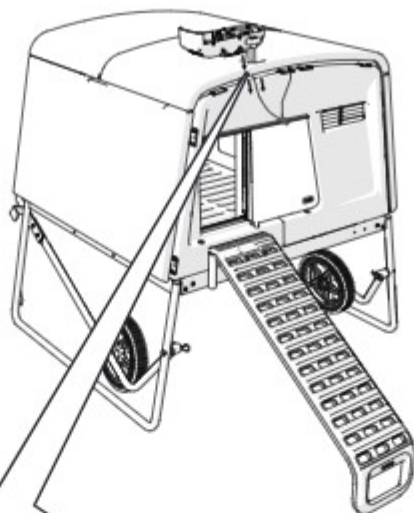
39

Pull wires tight.

- **DE** Ziehen Sie die Kabel fest an.
- **FR** Tirez sur les câbles pour les serrer.
- **NL** Trek de kabels strak aan.
- **IT** Tirare i cavi per stringerli.
- **ES** Tense los cables.
- **SE** Dra åt kablarna.
- **DK** Træk ledningerne stramt.

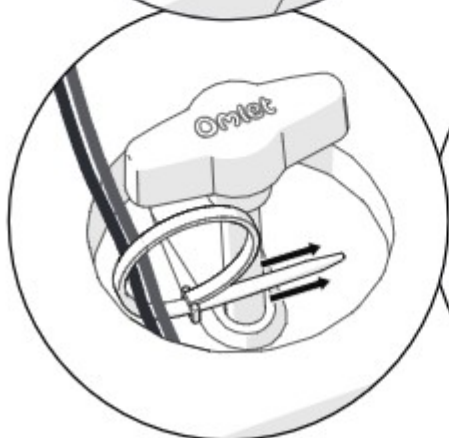

40

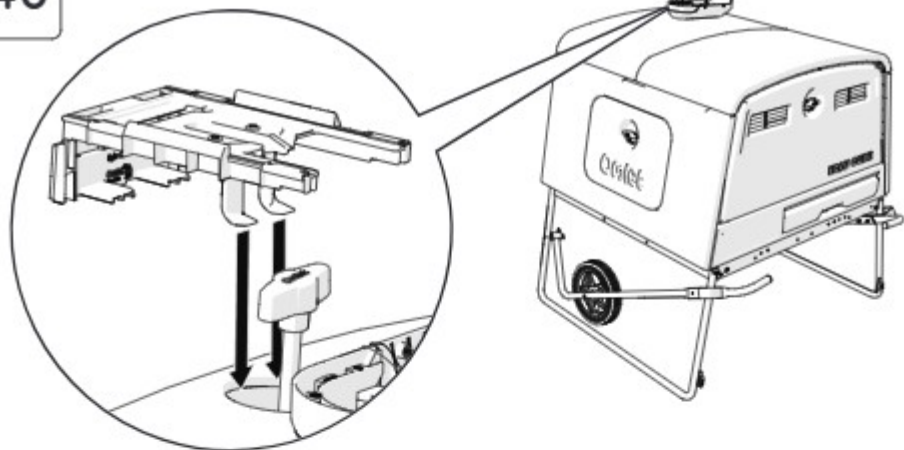

41

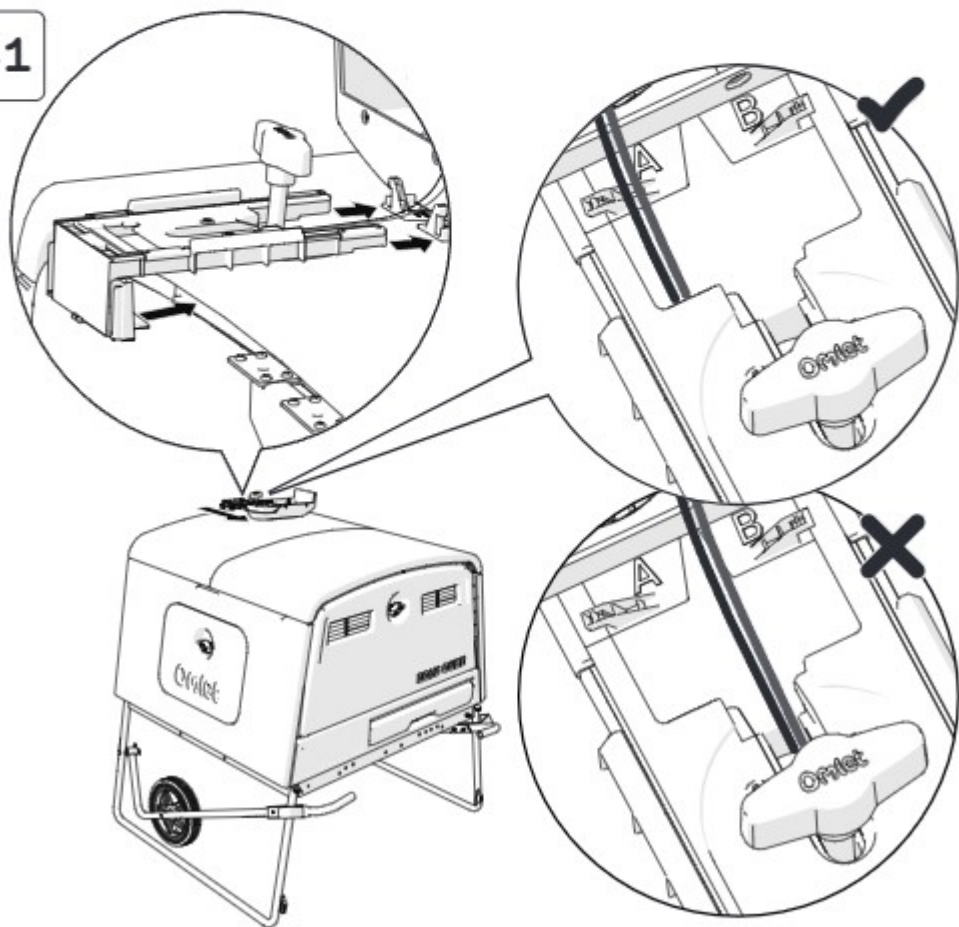

42

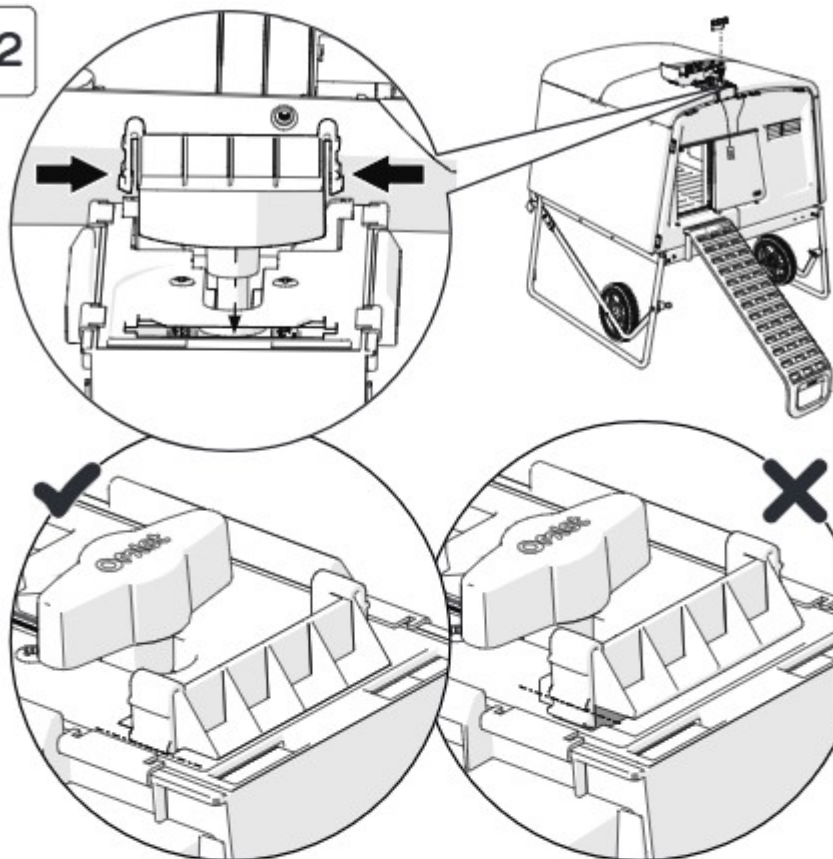

43

Pull wires tight.

- **DE** Ziehen Sie die Kabel fest an.
- **FR** Tirez sur les câbles pour les serrer.
- **NL** Trek de kabels strak aan.
- **IT** Tirare i cavi per stringerli.
- **ES** Tense los cables.
- **SE** Dra åt kablarna.
- **DK** Træk ledningerne stramt.

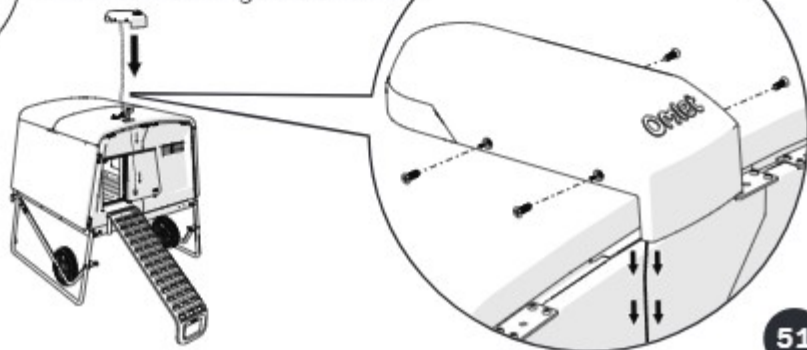

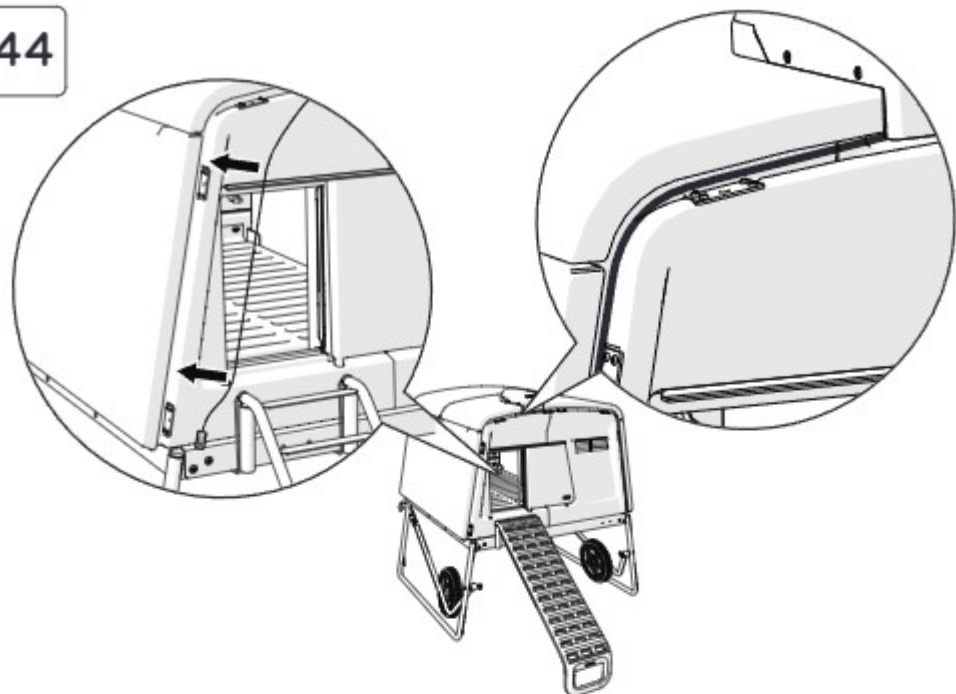

If you are attaching your coop to a Walk In Run Connection Kit.

DE Wenn Sie an Ihrem Stall einen Verbindungsbausatz für das Walk In Run – Begehbare Hühnergehege anbringen.

FR Si vous fixez votre poulailler à un kit de raccordement pour Grand Enclos.

NL Als u het kippenhok koppelt met een Verbindingsset voor Inloopen.

IT Se il pollaio viene collegato al kit di collegamento del recinto Walk-In.

ES Si va a acoplar su gallinero a un kit de conexión para recintos Walk In.

SE Om du ansluter ditt höns hus till ett sammanfogningskit för walk in-gårdar.

DK Hvis du fastgør dit hønses hus til et forbindelsessæt til en walk-in løbegård.



To Assemble the Control Panel (107.0014)

DE Zur Montage der **Steuereinheit (107.0014)**

FR Assemblage du **boîtier de contrôle (107.0014)**

NL Om het **Control Panel (107.0014)** te monteren

IT Per assemblare il **pannello di comando (107.0014)**

ES Ensamblar el **panel de control (107.0014)**

SE Montera **kontrollpanelen (107.0014)**

DK For at montere **kontrolpanelet (107.0014)**



Attaching your Smart Rotary Eglu Autodoor to an Eglu Pro.

DE Die Befestigung der intelligenten, drehbaren Eglu Autodoor an einem Eglu Pro.

FR Fixation de votre Porte Automatique intelligente rotative Eglu à un poulailler Eglu Pro.

NL De Slimme, roterende Eglu Autodoor bevestigen aan een Eglu Pro.

IT Collegare la Smart Autodoor girevole Eglu a un pollaio Eglu Pro.

ES Cómo conectar su puerta automática inteligente giratoria a un Eglu Pro.

SE Så montera du din smarta Autodörr till Eglu-hönshus på en Eglu Pro.

DK Fastgørelse af din smarte, roterende Eglu AutoDoor til en Eglu Pro.

45 Keep the Parts safe until Step 51.

- **DE** Legen Sie die Teile bis Schritt 51 beiseite.
- **FR** Mettez ces pièces de côté pour l'étape 51.
- **NL** Leg de onderdelen opzij tot stap 51.
- **IT** Mettere da parte fino al Punto 51.
- **ES** Guarde la pieza hasta el paso 51.
- **SE** Lägg undan delarna till steg 51.
- **DK** Læg delene til side indtil trin 51.

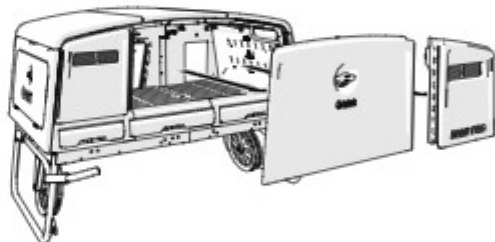

46 Keep the part safe until Step 51.

- **DE** Legen Sie das Teile bis Schritt 51 beiseite.
- **FR** Mettez cette pièce de côté pour l'étape 51.
- **NL** Leg het onderdeel opzij tot stap 51.
- **IT** Mettere da parte fino al Punto 51.
- **ES** Lägg undan delen till steg 51.
- **SE** Lägg undan delen till steg 51.
- **DK** Læg delen til side indtil trin 51.

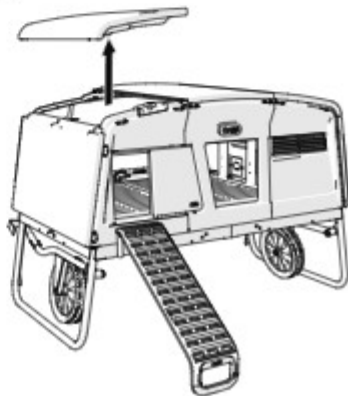

47

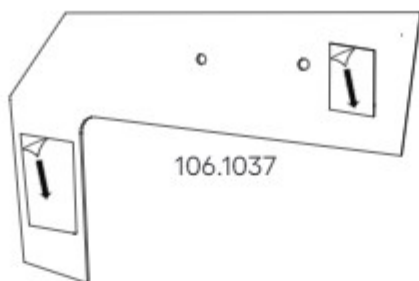

48

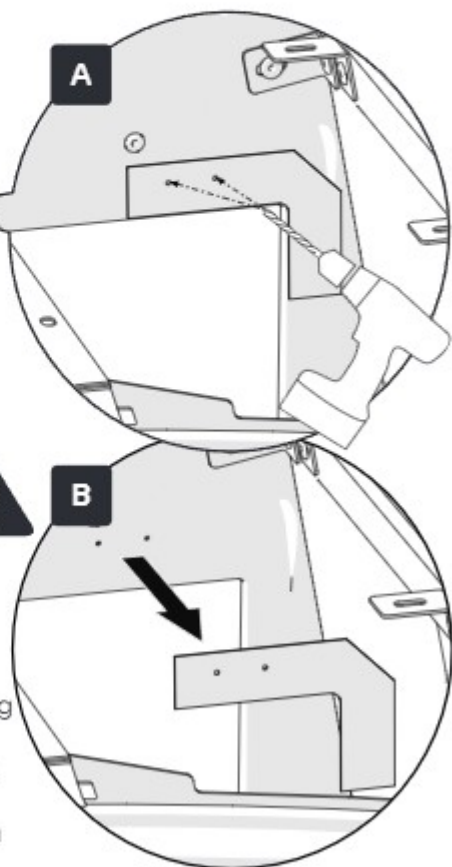
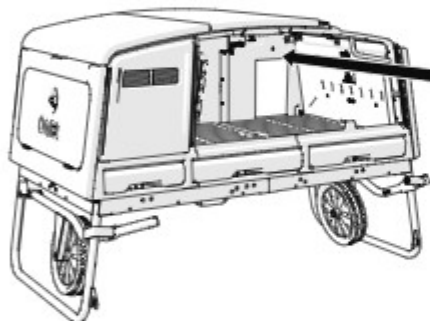

Only drill through the first inside layer of the panel.

- **DE** Bohren Sie nur durch die erste Innenschicht der Platte.
- **FR** Ne percez que la première couche intérieure du panneau.
- **NL** Boor allen door de eerste binnenlaag van het paneel.
- **IT** Forare solo il primo strato interno del pannello.
- **ES** Perfore únicamente la primera capa interior del panel.
- **SE** Borra endast genom det första inre lagret av panelen.
- **DK** Bor kun gennem det første indvendige lag af panelet.

49

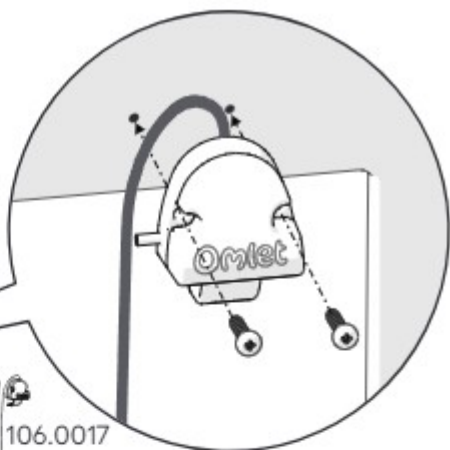
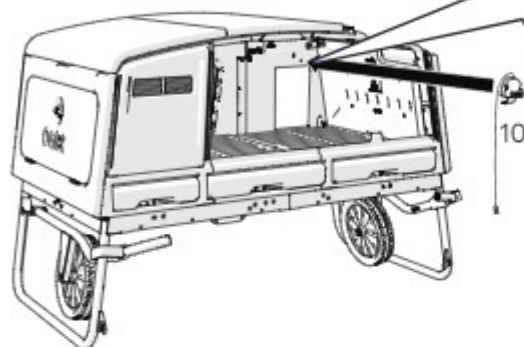

50

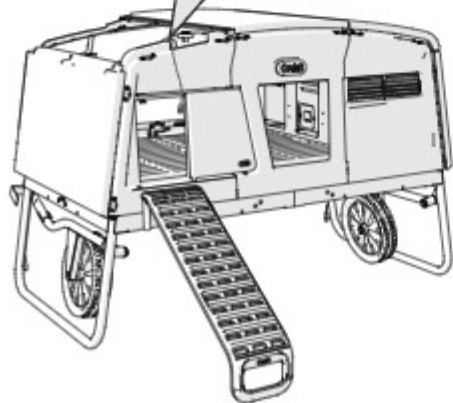
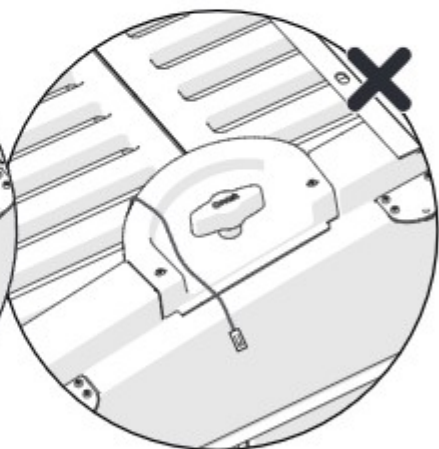
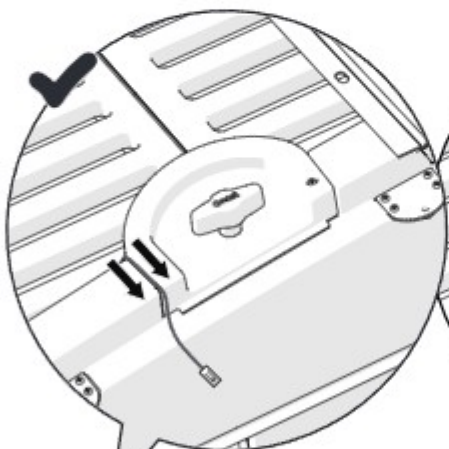

51

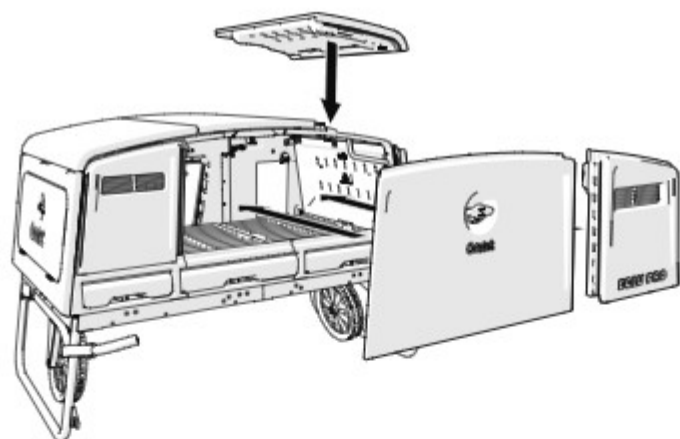

52

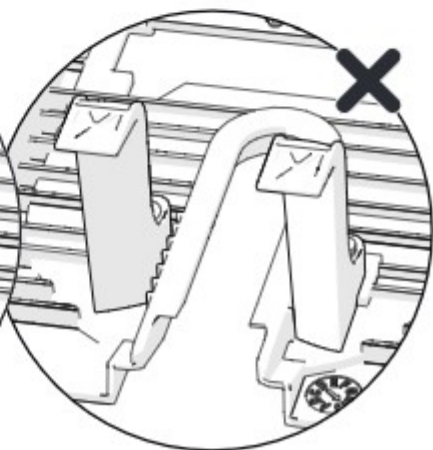
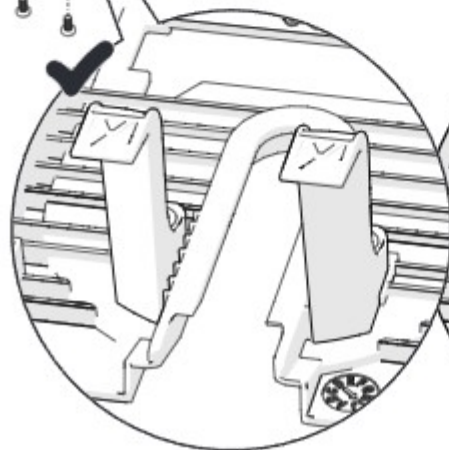
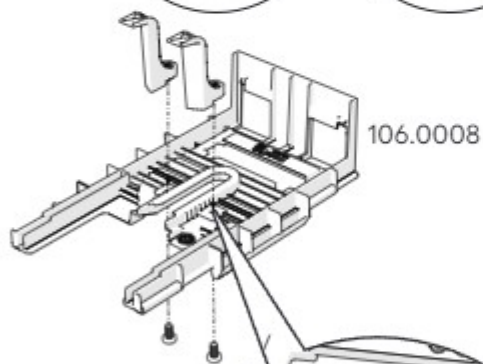
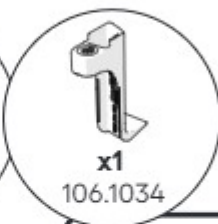
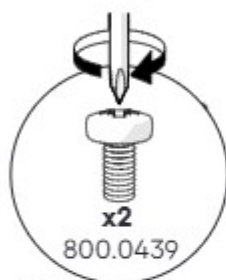

56

53

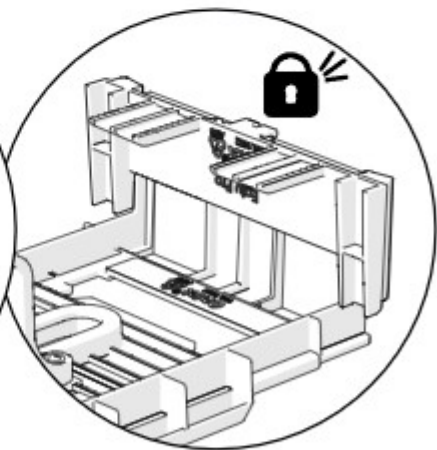
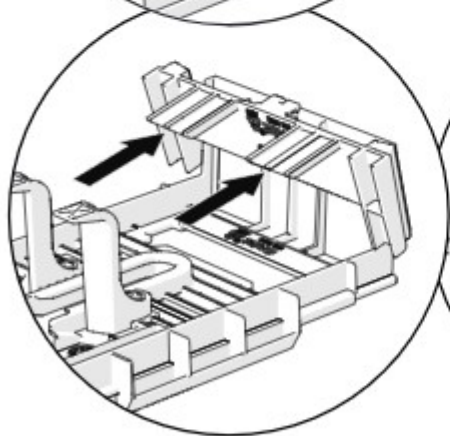
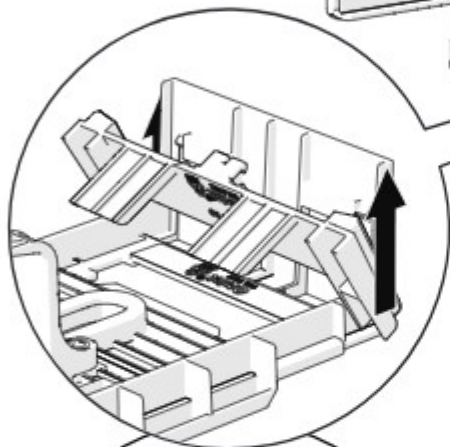
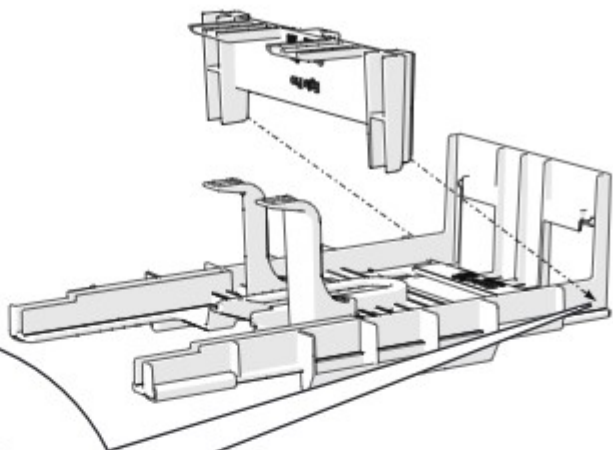
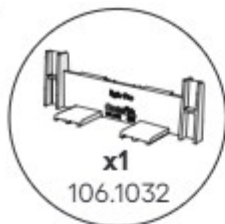

Make sure the area around your T-handle is clean and dry so your **Base Supports (106.0020, 106.0021)** can stick to it easily.



DE Stellen Sie sicher, dass der Bereich um den T-Griff sauber und trocken ist, damit die **Base Supports (106.0020, 106.0021)** leicht daran haften können.

FR Assurez-vous que la zone autour de votre poignée en T est propre et sèche afin que votre **Base Supports (106.0020, 106.0021)** puisse adhérer facilement.

NL Zorg dat het gebied rond de T-handgreep schoon en droog is, zodat de **Base Supports (106.0020, 106.0021)** gemakkelijk kan worden bevestigd.

IT Assicurarsi che l'area intorno all'impugnatura a T sia asciutta e pulita in modo che il **Base Supports (106.0020, 106.0021)** possa aderire facilmente.

ES Asegúrese de que la zona alrededor del tirador en T esté limpia y seca para que el **Base Supports (106.0020, 106.0021)** pueda adherirse fácilmente.

SE Se till att området runt ditt T-handtag är rent och torrt så att din **Base Supports (106.0020, 106.0021)** lätt kan fästa vid det.

DK Sørg for, at området omkring dit T-håndtag er rent og tørt, så din **Base Supports (106.0020, 106.0021)** nemt kan klæbe sig fast til det.

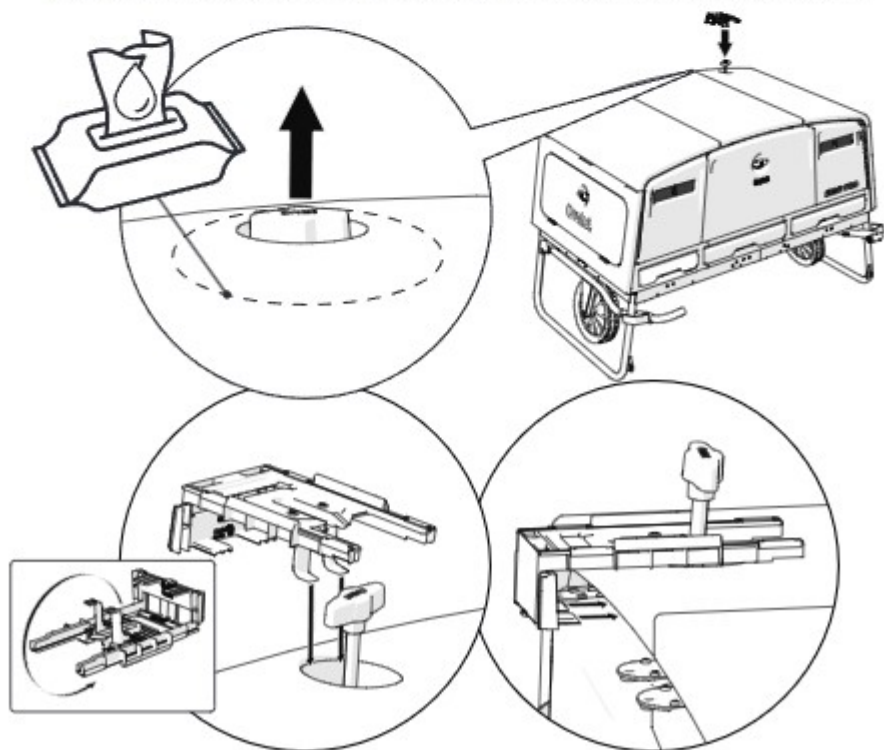

55

Push Base 106.0008 firmly against coop whilst marking out positions of 106.0020 and 106.0021.



DE Drücken Sie die Basis **106.0008** fest gegen den Stall, während Sie die Positionen von **106.0020** und **106.0021** markieren.

FR Appuyez fermement la base **106.0008** contre le poulailler tout en marquant les positions des pièces **106.0020** et **106.0021**.

NL Druk basis **106.0008** stevig tegen het hok terwijl je de posities van **106.0020** en **106.0021** markeert.

IT Spingere con fermezza la base **106.0008** contro il pollaio, contrassegnando al contempo le posizioni di **106.0020** e **106.0021**.

ES Empuje la base **106.0008** firmemente contra el gallinero mientras marca las posiciones de **106.0020** y **106.0021**.

SE Håll fast basen **106.0008** mot hönshuset när du markerar positionerna för **106.0020** och **106.0021**.

DK Skub base **106.0008** fast mod kabinettet, mens du markerer positionerne for **106.0020** og **106.0021**.

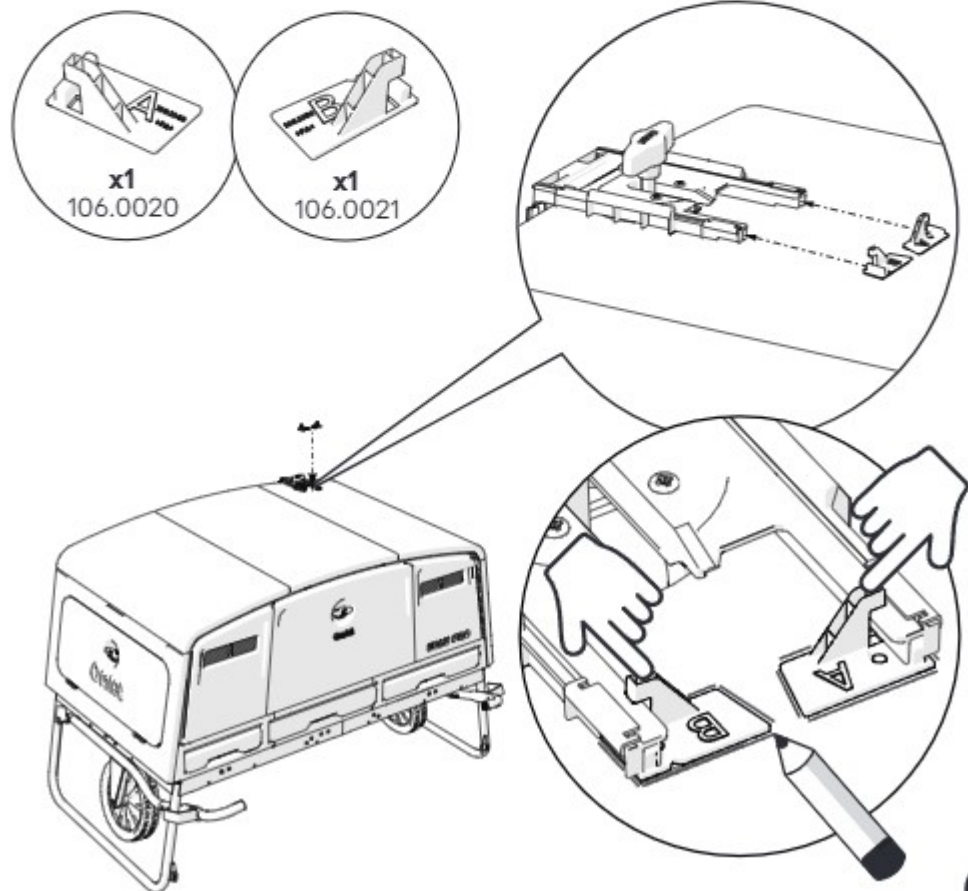

56

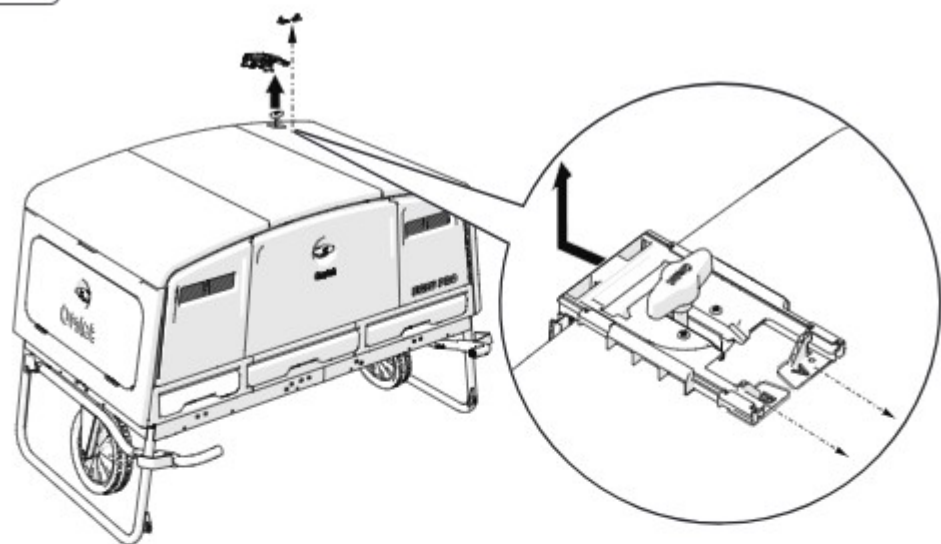

57

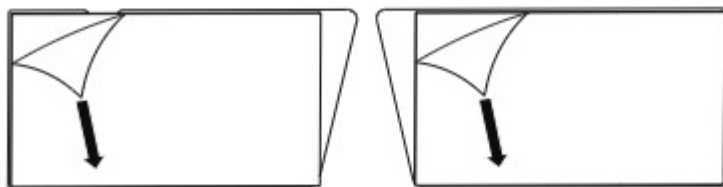

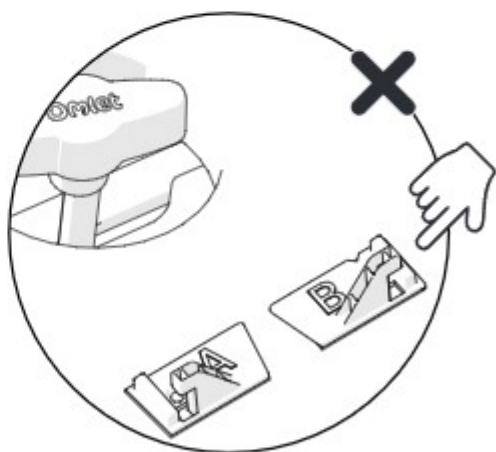
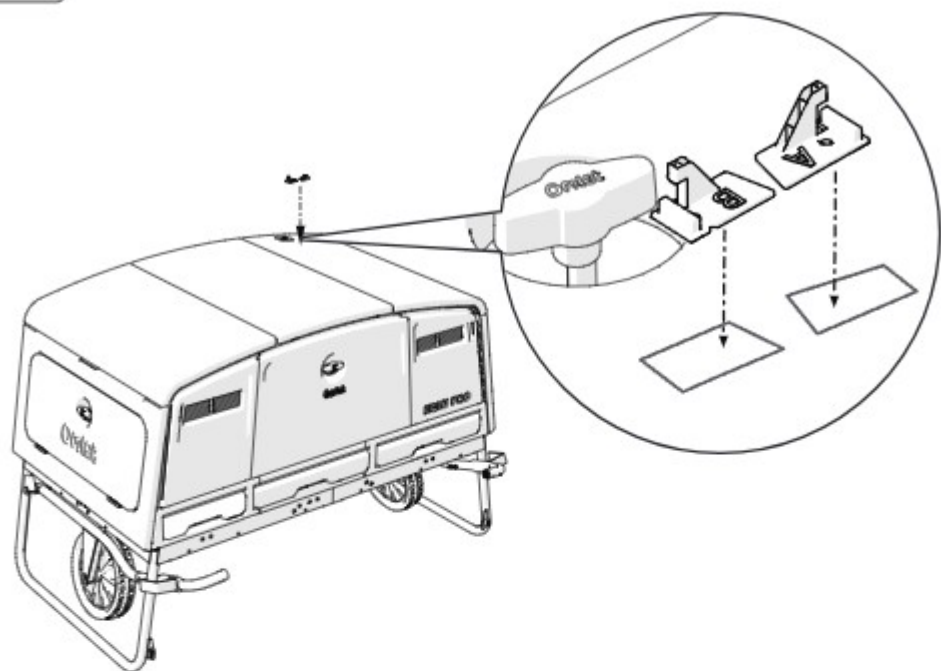

59

B

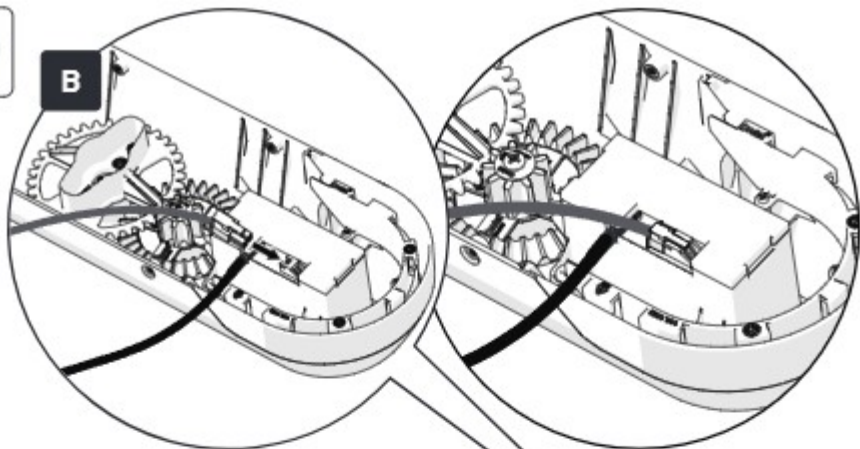

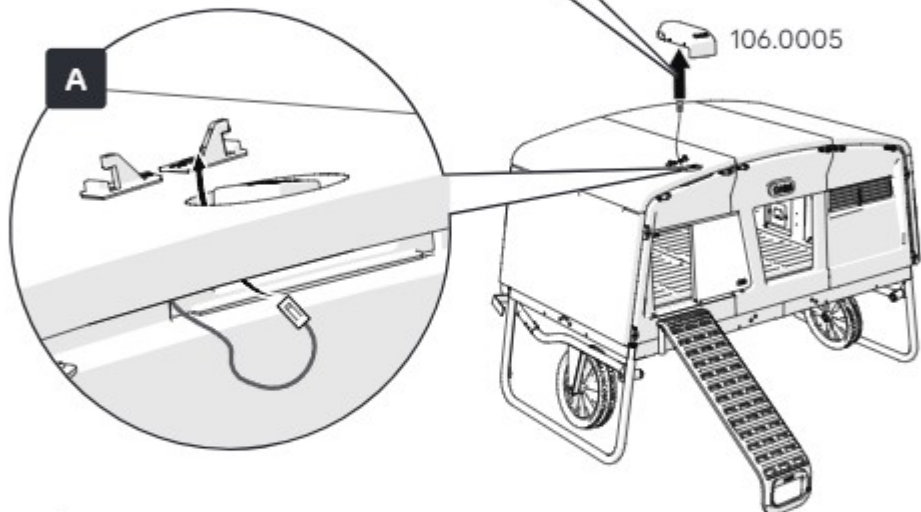

A

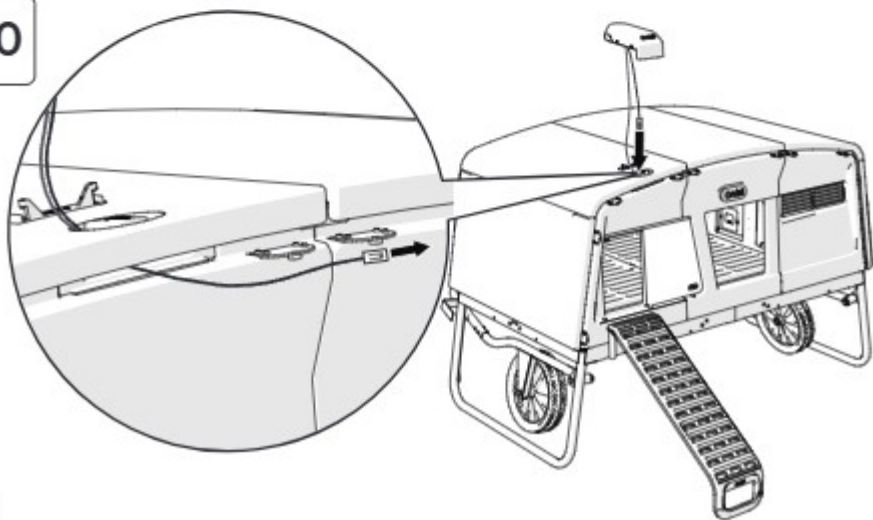

60

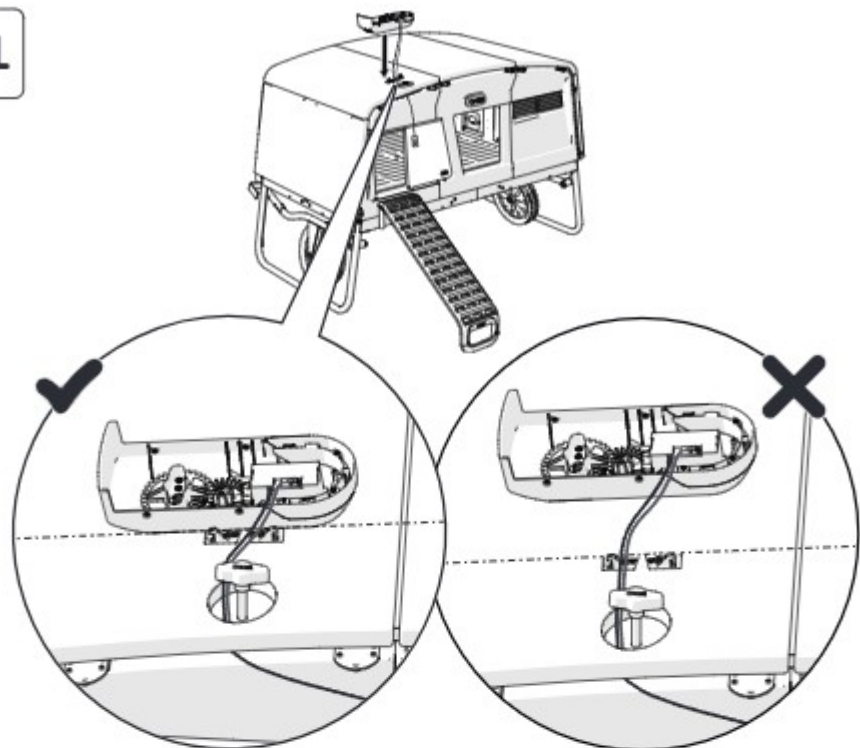



It is very important to position the gear case (106.0005) correctly on top of your coop to ensure wires will be the correct length during the next step. 

- **DE** Es ist äußerst wichtig, das getriebegehäuse (106.0005) richtig auf dem Stall zu positionieren, damit die Kabel beim nächsten Schritt die richtige Länge haben.
- **FR** Il est très important de positionner correctement le boîtier d'engrenages (106.0005) sur le dessus de votre poulailler pour que les câbles soient de la bonne longueur lors de l'étape suivante.
- **NL** Het is uiterst belangrijk dat de gear case (106.0005) correct op het hok te plaatsen, zodat de kabels de juiste lengte hebben tijdens de volgende stap.
- **IT** È molto importante posizionare la centralina (106.0005) nella maniera corretta sul pollaio in modo che i cavi siano della lunghezza adeguata nello step successivo.
- **ES** Es muy importante colocar correctamente la caja de engranajes (106.0005) en la parte superior del gallinero para que los cables tengan la longitud adecuada para el siguiente paso..
- **SE** Det är mycket viktigt att placera gear case (106.0005) korrekt ovanpå ditt höns hus för att se till att kablarna har rätt längd under nästa steg.
- **DK** Det er meget vigtigt at placere gearkassen (106.0005) korrekt oven på dit høns hus for at sikre, at ledningerne har den korrekte længde under næste trin.

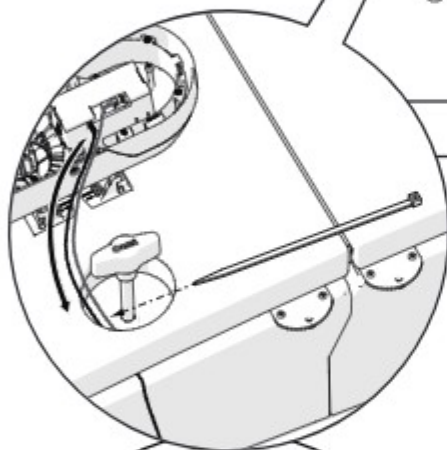
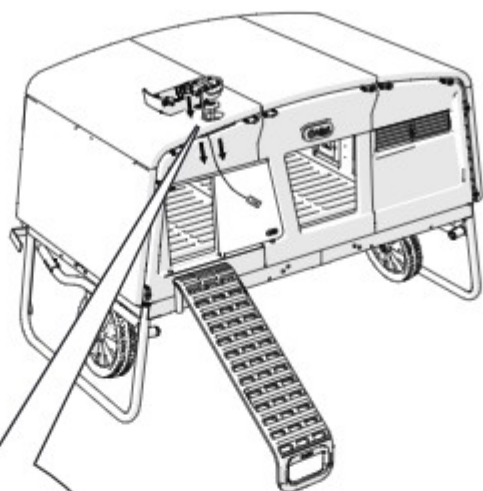

Pull wires tight.

- **DE** Ziehen Sie die Kabel fest an.
- **FR** Tirez sur les câbles pour les serrer.
- **NL** Trek de kabels strak aan.
- **IT** Tirare i cavi per stringerli.
- **ES** Tense los cables.
- **SE** Dra åt kablarna.
- **DK** Træk ledningerne stramt.

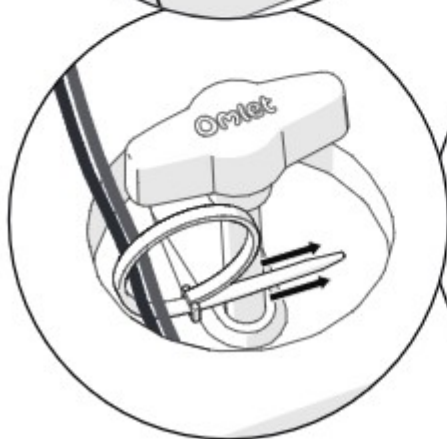

63

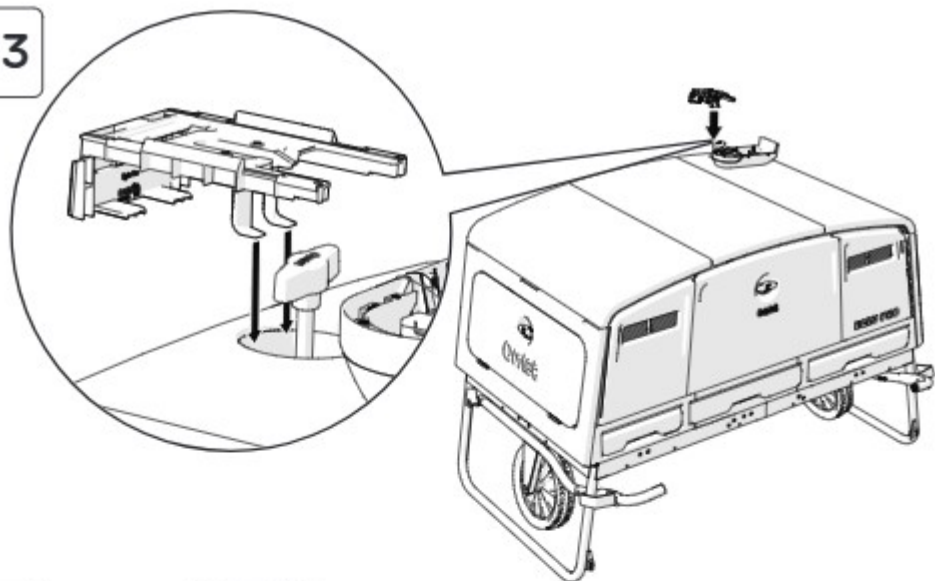

64

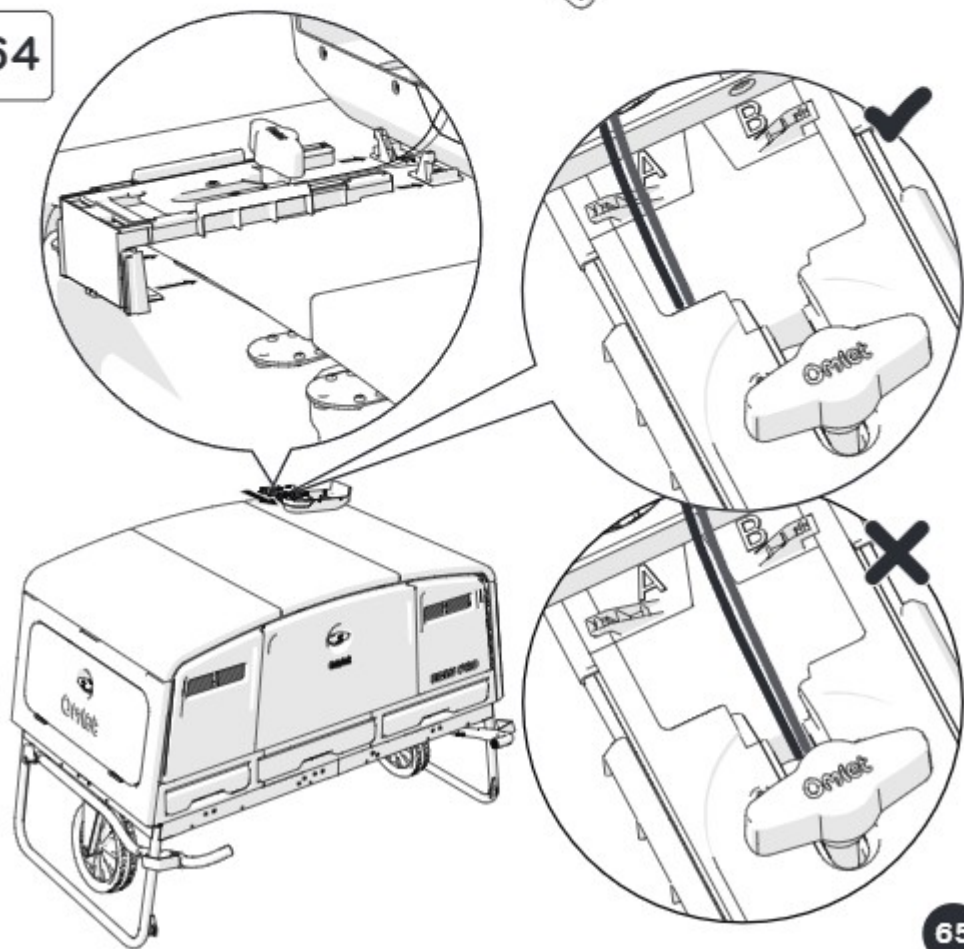

65

65

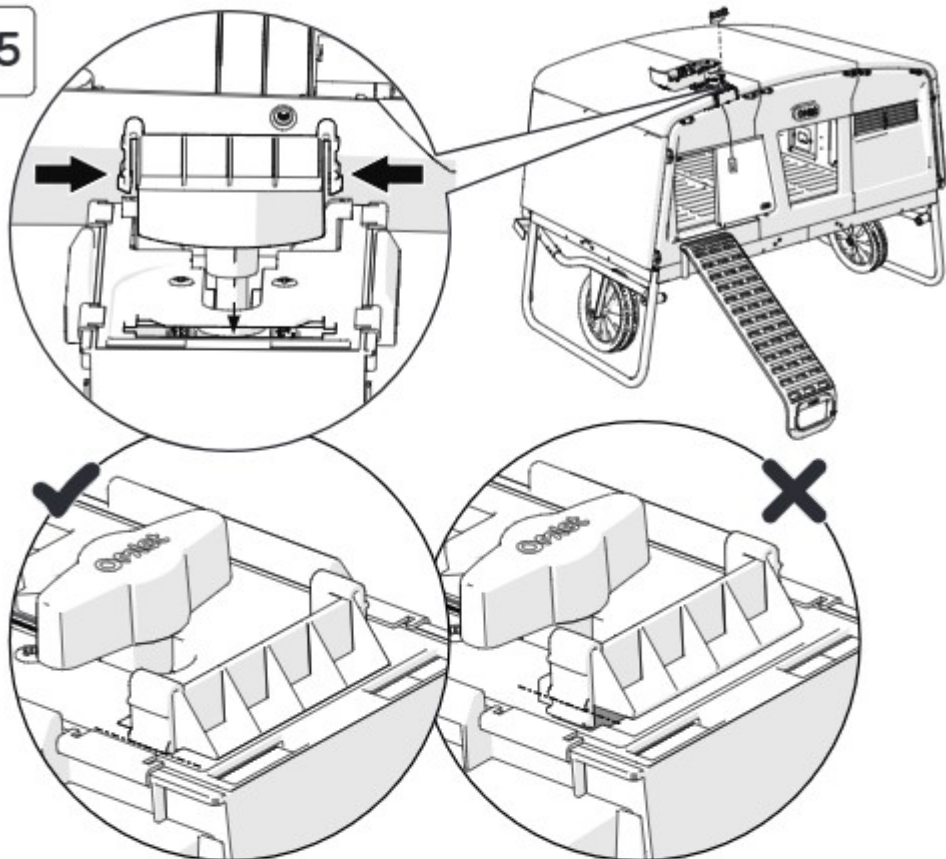

66

Pull wires tight.



- **DE** Ziehen Sie die Kabel fest an.
- **FR** Tirez sur les câbles pour les serrer.
- **NL** Trek de kabels strak aan.
- **IT** Tirare i cavi per stringerli.
- **ES** Tense los cables.
- **SE** Dra åt kablar.
- **DK** Træk ledningerne stramt.

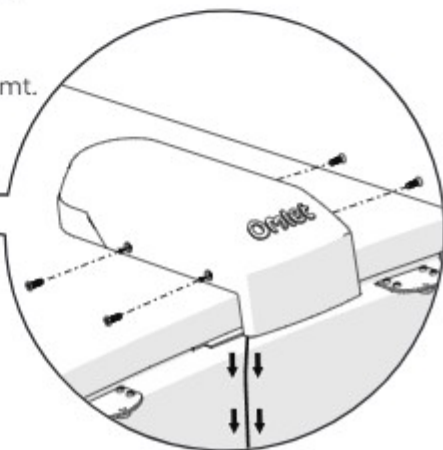
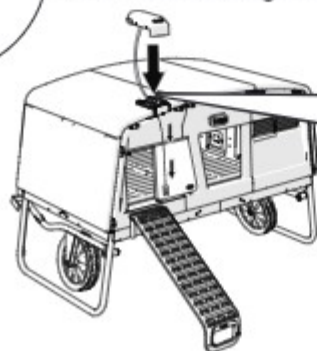

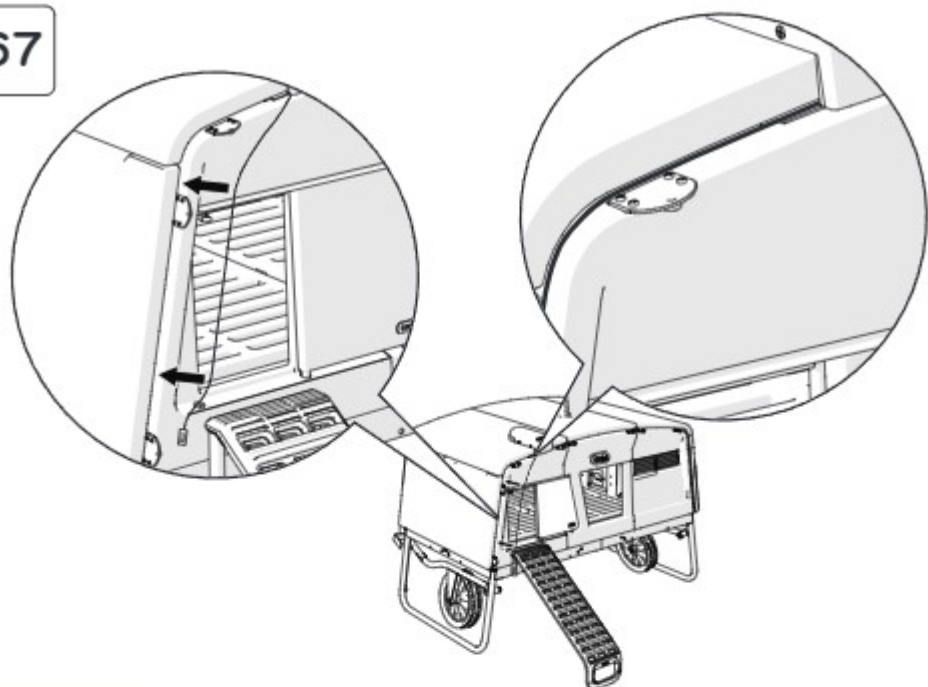

If you are attaching your coop to a Walk In Run Connection Kit.

DE Wenn Sie an Ihrem Stall einen Verbindungsbausatz für das Walk In Run – Begehbare Hühnergehege anbringen.

FR Si vous fixez votre poulailler à un kit de raccordement pour Grand Enclos.

NL Als u het kippenhok koppelt met een Verbindingsset voor Inloopren.

IT Se il pollaio viene collegato al kit di collegamento del recinto Walk-In.

ES Si va a acoplar su gallinero a un kit de conexión para recintos Walk In.

SE Om du ansluter ditt höns hus till ett sammanfogningskit för walk in-gårdar.

DK Hvis du fastgør dit hønsehus til et forbindelsessæt til en walk-in løbegård.



68

To Assemble the Control Panel (107.0014)

DE Zur Montage der **Steuereinheit (107.0014)**

FR Assemblage du **boîtier de contrôle (107.0014)**

NL Om het **Control Panel (107.0014)** te monteren

IT Per assemblare il **pannello di comando (107.0014)**

ES Ensamblar el **panel de control (107.0014)**

SE Montera **kontrollpanelen (107.0014)**

DK For at montere **kontrolpanelet (107.0014)**



70

Setup with Walk In Run Connection Kit.

DE Installation am Walk In Run – Begehbaren Gehege Verbindungsbausatz.

FR Installation sur un Grand Enclos avec kit de raccordement.

NL Bevestigen op de Inloopren Verbindingsset.

IT Installazione a un recinto Walk-In con kit di collegamento.

ES Puesta en marcha en un recinto Walk In con kit de conexión.

SE Installation med ett sammanfogningskit för walk-in gårdar.

DK Opsætning med en walk-in løbegård forbindelsessæt.

68

Eglu Go

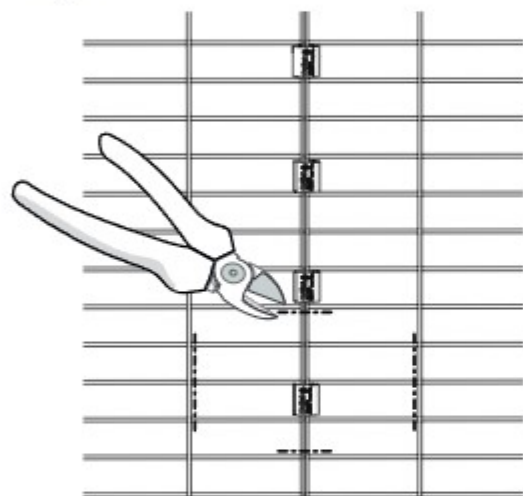

Eglu Cube Mk2

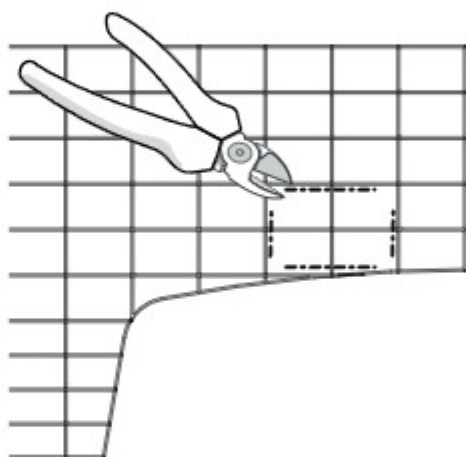

Eglu Pro

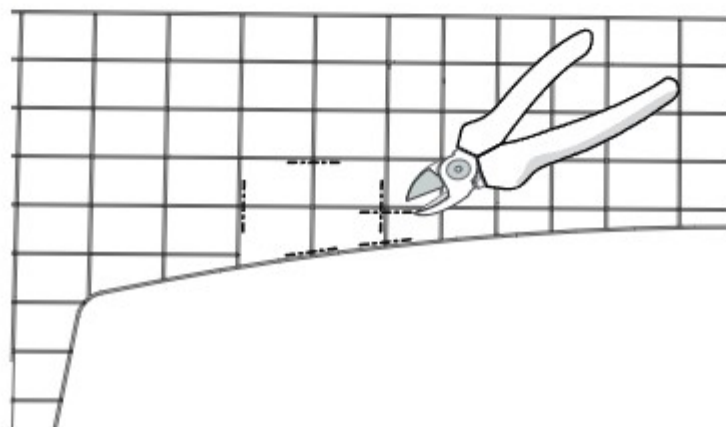

Eglu Go

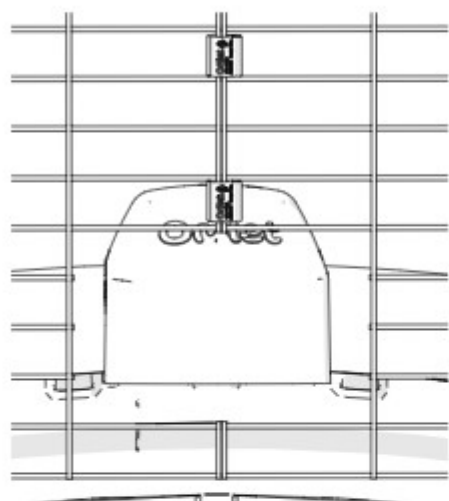

Eglu Cube Mk2

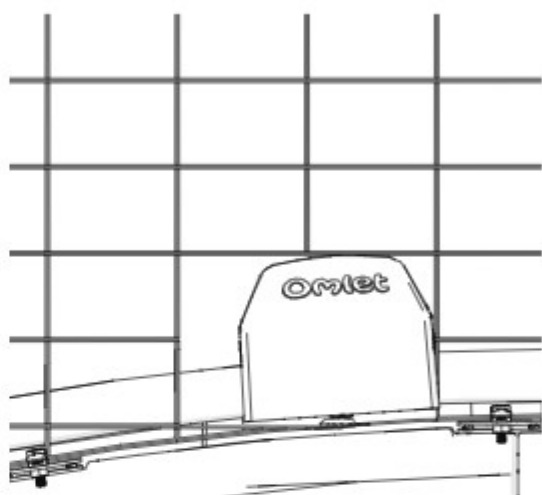

Eglu Pro

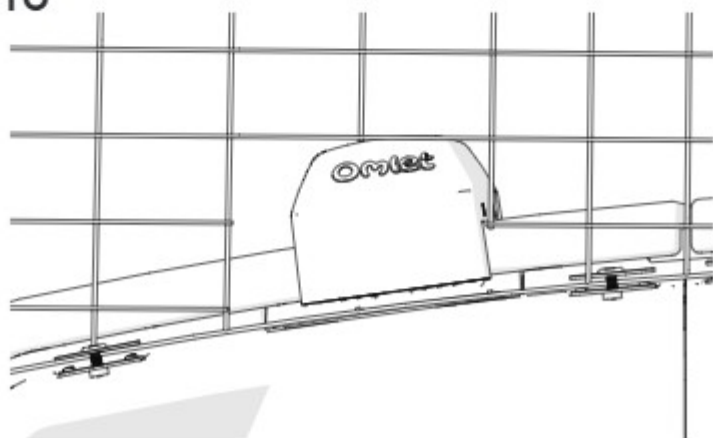

Assemble the control panel

DE Die Steuerungseinheit anschließen · **FR** Assemblage du tableau de bord
NL Het bedieningspaneel monteren · **IT** Assemblare il Pannello di Controllo
ES Ensablaje del panel de control · **SE** Sätt ihop kontrollpanelen
DK Saml kontrolpanelet

70

Keep the Parts safe until Steps 72-73. 

- **DE** Legen Sie die Teile bis Schritte 72 & 73 beiseite.
- **FR** Mettez ces pièces de côté pour les étapes 72-73.
- **NL** Leg de onderdelen opzij tot stap 72-73.
- **IT** Mettere da parte fino ai Punti 72-73.
- **ES** Guarde la pieza hasta los pasos 72-73.
- **SE** Lägg undan delarna till Steg 72-73.
- **DK** Læg delene til side indtil trin 72-73.

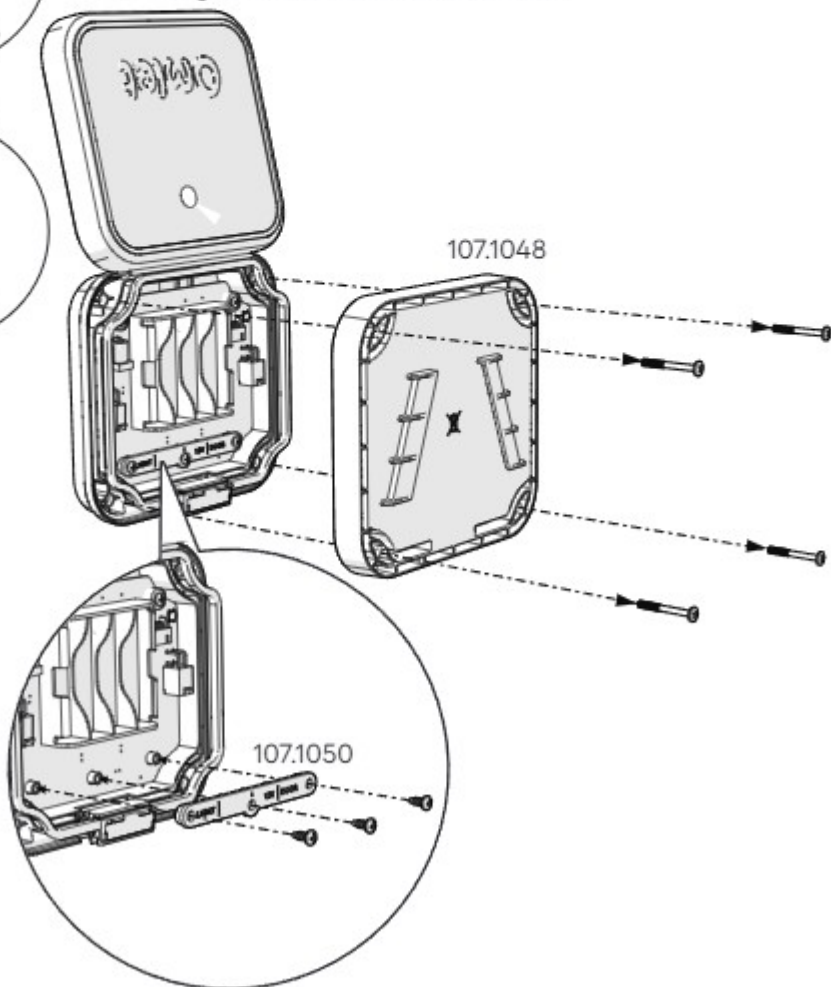

To power your Control Panel you can use batteries or the Omlet Power Adaptor. The power supply is required to enable responsive mode when connected to Wifi. Do not use both options simultaneously.



- **DE** Für die Stromversorgung Ihrer Steuereinheit können Sie Batterien oder den Omlet Netzadapter verwenden. Der Netzadapter ist erforderlich, um bei bestehender Wi-Fi-Verbindung den Modus „Empfangsbereit“ zu aktivieren. Verwenden Sie nicht beide Optionen gleichzeitig.
- **FR** Pour alimenter votre boîtier de contrôle, vous pouvez utiliser des piles ou l'adaptateur secteur Omlet. L'alimentation électrique est nécessaire pour activer le mode réactif lorsque le boîtier est connecté au Wi-Fi. N'utilisez pas simultanément les piles et l'adaptateur secteur.
- **NL** Om je bedieningspaneel van stroom te voorzien kun je batterijen of de Omlet stroomadapter gebruiken. De stroomadapter is nodig om de responsieve modus in te schakelen wanneer je verbonden bent met Wifi. Gebruik beide opties niet tegelijkertijd.
- **IT** Per alimentare il Pannello di Comando, potete utilizzare le batterie o l'alimentatore di Omlet.
L'alimentazione è necessaria per attivare la modalità responsive quando il pannello di comando è collegato al Wi-Fi. Non utilizzare entrambe le opzioni di alimentazione contemporaneamente.
- **ES** Para alimentar el panel de control, puede usar pilas o el adaptador de corriente Omlet. La fuente de alimentación es necesaria para activar el modo de respuesta al conectarse a la red wifi. No utilice ambas opciones simultáneamente.
- **SE** Du kan driva din kontrollpanel med batterier eller med Omlets nätadapter. Kontrollpanelen måste vara ansluten via nätadapter för att du ska kunna använda alla funktioner när du är ansluten till WiFi. Använd inte båda alternativen samtidigt.
- **DK** For at strømforsyne dit kontrolpanel kan du bruge batterier eller Omlets strømadapter. Strømforsyningen er nødvendig for at aktivere responsiv tilstand, når den er forbundet til wi-fi. Brug ikke begge muligheder samtidigt.

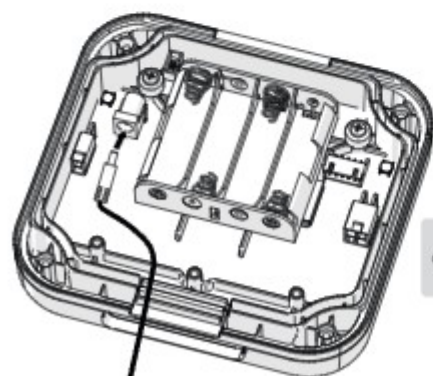

Omlet 12V Power
Supply
x1

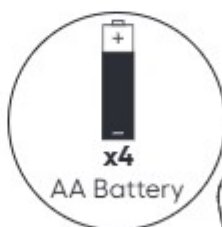

x4
AA Battery

OR

oder · ou ·
of · oppure o ·
eller · lub

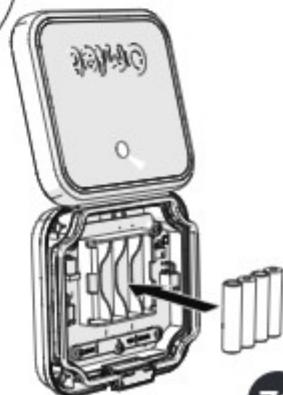

Check your batteries every 3 months. Always use 4 batteries of the same brand and energy level.



- **DE** Überprüfen Sie Ihre Batterien alle 3 Monate. Verwenden Sie immer 4 Batterien der gleichen Marke und des gleichen Energieniveaus.
- **FR** Vérifiez les piles tous les 3 mois. Utilisez toujours 4 piles de même marque et de même niveau d'énergie.
- **NL** Controleer de batterijen elke drie maanden. Gebruik vier batterijen van hetzelfde merk en voltage.
- **IT** Controllate le batterie ogni 3 mesi. Usate sempre 4 batterie della stessa marca e di livello energetico.
- **ES** Revise sus pilas cada 3 meses. Utilice siempre 4 pilas de la misma marca y nivel de energía.
- **SE** Kontrollera batterierna var tredje månad. Använd alltid fyra batterier av samma märke och energinivå.
- **DK** Tjek dine batterier hver 3. måned. Brug altid 4 batterier af samme mærke og energiniveau.

If you have a Coop Light, refer to Coop Light instruction manual now or scan the code or visit: omlet.co.uk/support



- **DE** Wenn Sie ein Stall-Licht besitzen, folgen Sie nun bitte der Anleitung für das Stall-Licht oder scannen Sie den Code bzw. besuchen Sie: www.omlet.de/support/
- **FR** Si vous disposez d'une veilleuse, veuillez consulter le manuel d'instructions de la veilleuse. Vous pouvez aussi scanner le code ou cliquer sur le lien ci-dessous: <https://www.omlet.fr/support/>
- **NL** Indien u een kippenhoklamp heeft, raadpleeg dan de gebruiksaanwijzing van de kippenhoklamp. U kan ook de code scannen of deze site bezoeken: www.omlet.nl/support/
- **IT** Se avete una Luce per pollai, fate riferimento al manuale d'istruzioni per Luce da pollai o scansionate il codice o visitate: <https://www.omlet.it/support/>
- **ES** Si tiene una luz para gallinero, consulte ahora el manual de instrucciones de la luz para gallinero, escanee el código o visite la web: www.omlet.es/support/
- **SE** Om du har en hönslyslampa hittar du instruktionerna i bruksanvisningen som tillhör den. Du kan också skanna koden eller besöka: <https://www.omlet.se/support/>
- **DK** Hvis du har en hønselyslampe så se venligst brugsanvisningen til denne nu, scan koden eller besøg: www.omlet.dk/support/

72

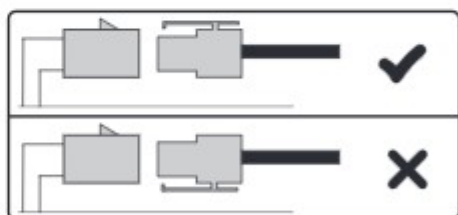
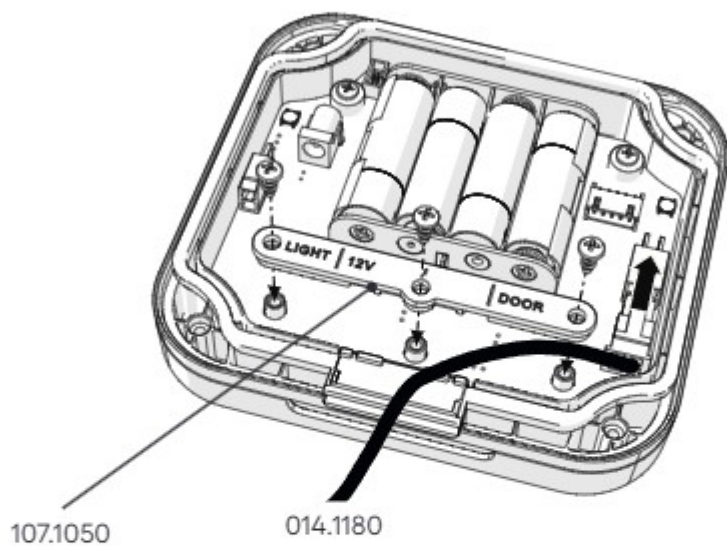

73

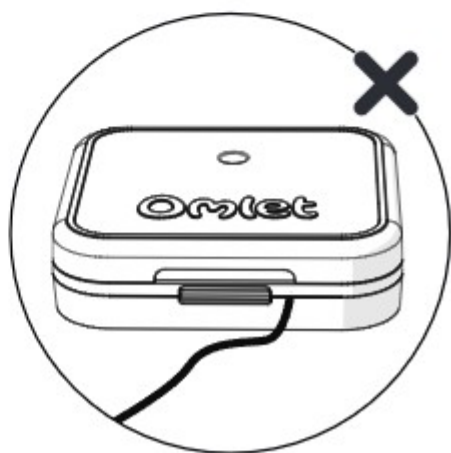
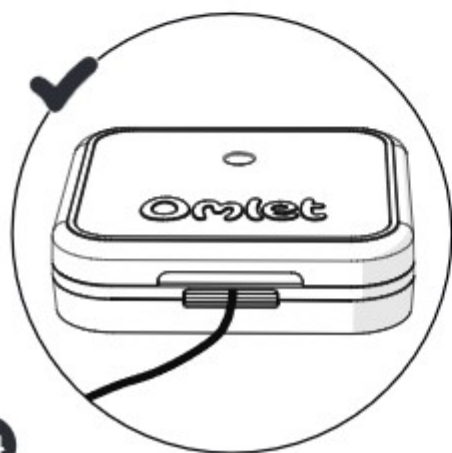
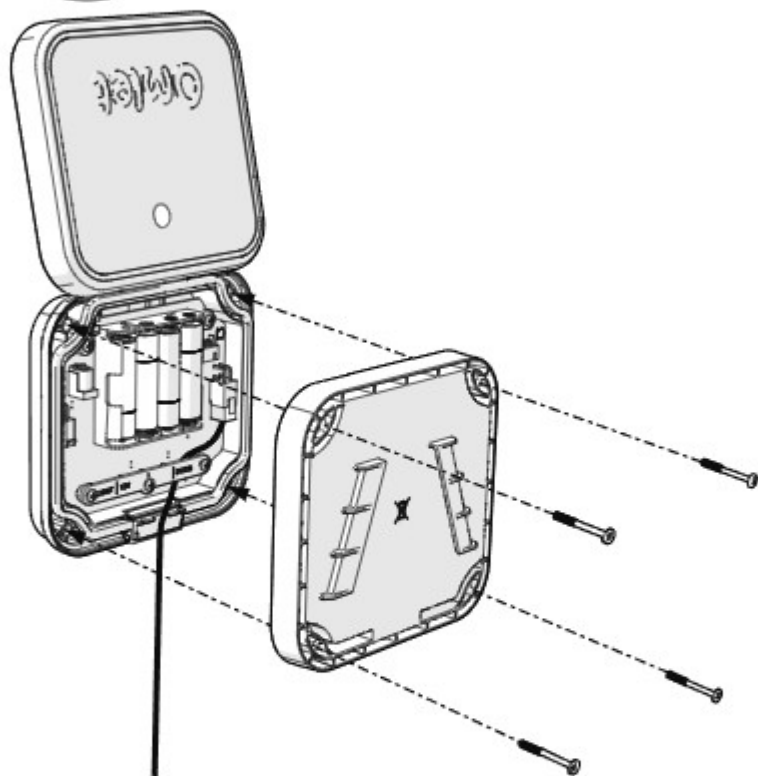

74

DE Die Steuerungseinheit anbringen · **FR** Assemblage du tableau de
NL Het bedieningspaneel monteren · **IT** Assemblare il Pannello di
ES Montaje del panel de control · **SE** Sätt ihop kontrollpanelen
DK Saml kontrolpanelet

Mount the Control Panel so that the Light Sensor can receive natural light throughout the day.

DE Bringen Sie die Steuerungseinheit so an, dass der Lichtsensor den Tag über natürliches Licht empfangen kann.

FR Lorsque vous fixez le tableau de bord, assurez-vous que le capteur soit bien exposé à la lumière.

NL Plaats het bedieningspaneel zo dat de lichtsensor gedurende de dag natuurlijk licht kan opvangen.

IT Montare il Pannello di Controllo facendo attenzione che il Sensore di Luminosità riceva sempre luce naturale durante tutto il giorno.

ES Monte el panel de control de forma que el sensor de luz pueda recibir luz natural durante todo el día.

SE Sätt kontrollpanelen så att ljussensorn kan få naturligt ljus under hela dagen.

DK Monter kontrolpanelet, så lyssensoren kan modtage dagslys hele dagen.



Light Sensor

- **DE** Lichtsensor
- **FR** Capteur de lumière
- **NL** Lichtsensor
- **IT** Sensore Luminosità
- **ES** Sensor de luz
- **SE** Ljussensor
- **DK** Lyssensor

Do not put the Control Panel under cover. Be aware, weather conditions, orientation, seasonal light levels and artificial lights around the house and garden can also significantly affect the light reading.



- **DE** Decken Sie die Steuerungseinheit nicht ab. Beachten Sie auch, dass die Wetterbedingungen, die Ausrichtung, die jahreszeitlich bedingten Lichtverhältnisse und künstliche Beleuchtung am Haus und im Garten die Lichtanzeige erheblich beeinflussen können.
- **FR** Ne recouvrez jamais le tableau de bord. Attention : l'orientation du capteur et les conditions climatiques peuvent grandement affecter le capteur de lumière.
- **NL** Bedek het bedieningspaneel niet. Houd er rekening mee dat ook weersomstandigheden, oriëntatie, verandering van het lichtniveau per seizoen en kunstlicht rond het huis en in de tuin de lichtsensor kunnen beïnvloeden.
- **IT** Non coprite mai il pannello di controllo. Fate attenzione perché le condizioni meteo, l'orientamento, i livelli di luce stagionali e le luci artificiali vicino a casa e al giardino possono compromettere la lettura della luce.
- **ES** No cubra el panel de control. Tenga en cuenta que las condiciones meteorológicas, la orientación, los niveles de luz estacionales y las luces artificiales de la casa y el jardín también pueden afectar significativamente a la sensibilidad para detectar la luz.
- **SE** Sätt inte kontrollpanelen på en täckt plats. Uppmärksamma att väder, placering, olika ljusnivåer beroende på säsong och ljus från andra ljuskällor i hörnhuset och trädgården också märkbart kan påverka avläsningen av ljuset.
- **DK** Undlad at sætte kontrolpanelet på et overdækket område. Vær opmærksom på at vejrforhold, orientering, årstidernes varierende lys og kunstig belysning også kan påvirke lysmålingen betydeligt.

Eglu Go



Eglu Cube Mk2



Eglu Pro



75 Mounting to the Eglu Go

DE Montage am Eglu Go • **FR** Montage sur le poulailler Eglu Go

NL Monteren op Eglu Go • **IT** Montaggio su Eglu Go

ES Montaje en el Eglu Go • **SE** Montering på Eglu Go

DK Montering på Eglu Go

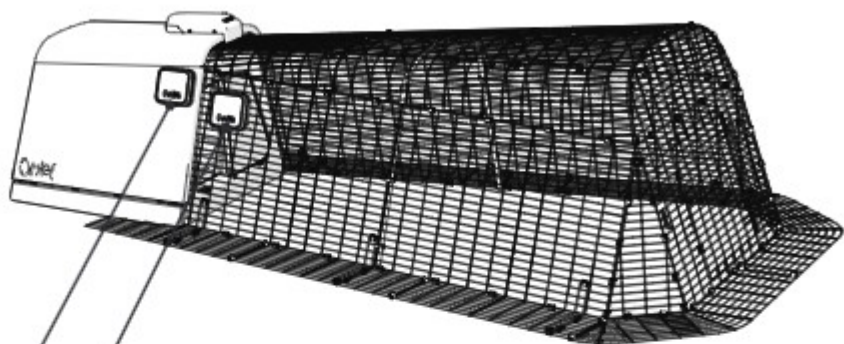

→ 76

→ 80

76

106.1047

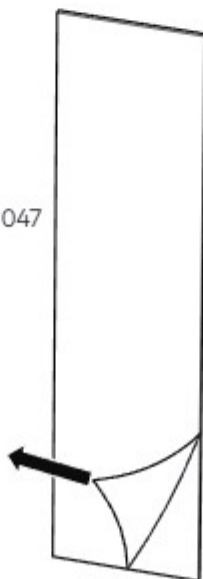

77

Make sure the coop's and bracket's surfaces are clean and dry before sticking. Do not try to adjust or remove the mount once it has been stuck in position.



- **DE** Stellen Sie sicher, dass die Oberflächen des Hühnerstalls und der Halterung sauber und trocken sind, bevor Sie sie festkleben. Versuchen Sie nicht, die Halterung anzupassen oder zu entfernen, nachdem sie befestigt wurde.
- **FR** Assurez-vous que les surfaces du poulailler et du support sont propres et sèches avant de coller le support. N'essayez pas de bouger ou de retirer le support une fois qu'il a été collé.
- **NL** Zorg ervoor dat de oppervlakken van het hok en de beugel schoon en droog zijn voordat je begint met vastplakken. Probeer niet om de bevestiging aan te passen of te verwijderen als deze eenmaal op zijn plaats is geplakt.
- **IT** Assicurarsi che le superfici del pollaio e del supporto siano asciutte e pulite prima di collocare il supporto. Non tentare di spostare o rimuovere il supporto una volta applicato.
- **ES** Asegúrese de que las superficies del gallinero y del soporte estén limpias y secas antes de pegarlo. No intente ajustar ni retirar el soporte una vez fijado.
- **SE** Se till att ytorna både på hönshuset och fästet är rena och torra innan du börjar. Försök inte justera eller ta bort fästet efter att du har fäst det.
- **DK** Sørg for, at hønsehusets og beslagets overflader er rene og tørre, før du sætter dem fast. Forsøg ikke at justere eller fjerne beslaget, når det er sat fast.

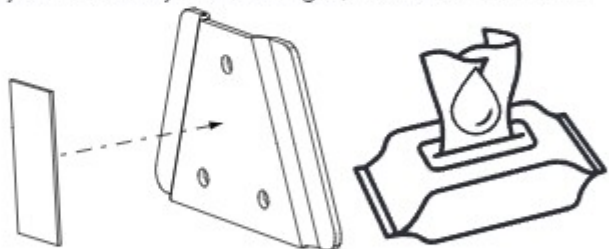

78

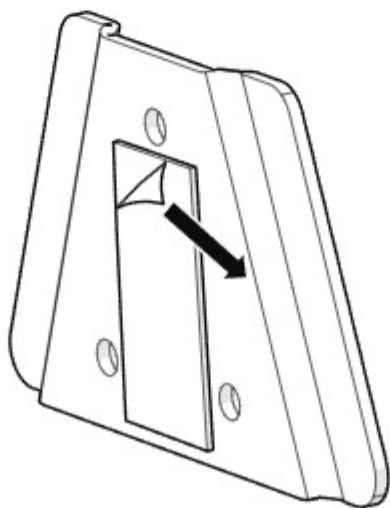

79

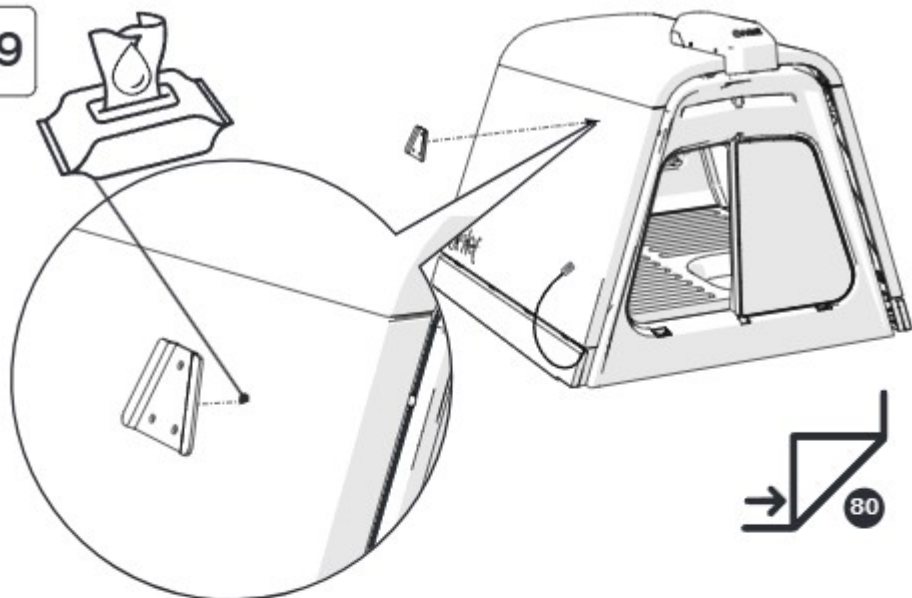

80

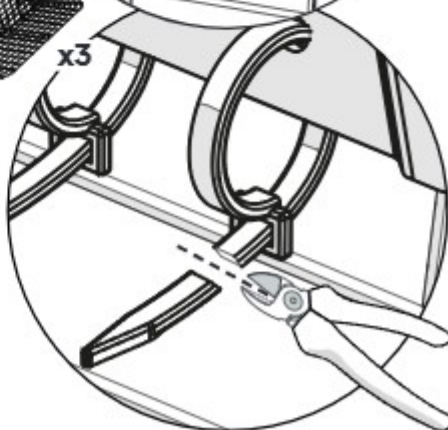
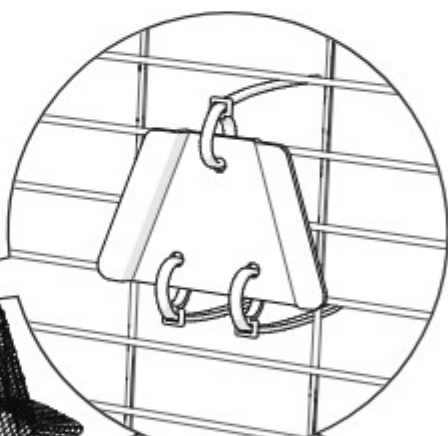
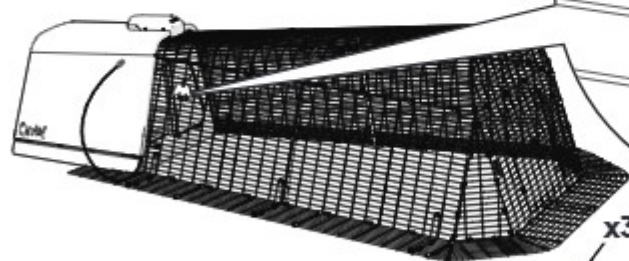
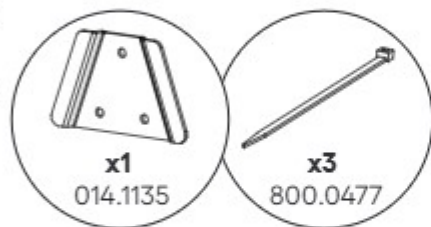

79

81



or

oder · ou ·
of · oppure o ·
eller · lub

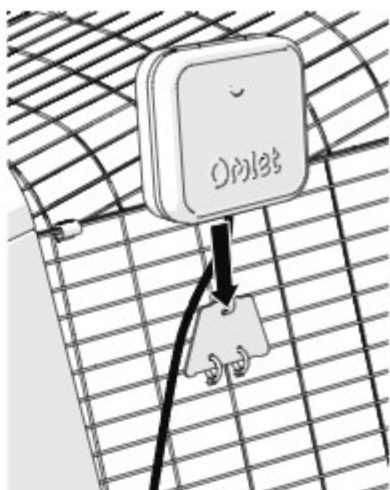

82 Optional



- DE Optional
- FR Facultatif
- NL Optioneel
- IT Opzionali
- SE Valfri
- DK Valgfri



x1

or

oder · ou ·
of · oppure o ·
eller · lub

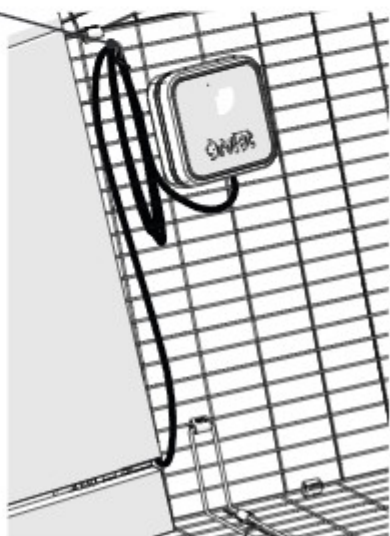
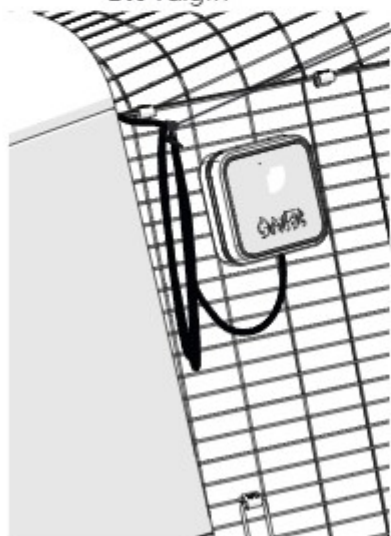

83 Mounting to the Cube

DE Montage am Eglu Cube • **FR** Montage sur le poulailler Eglu Cube
NL Monteren op Cube • **IT** Sistema di apertura di emergenza
ES Montaje en el Cube • **SE** Montering på Cube
DK Montering på Cube

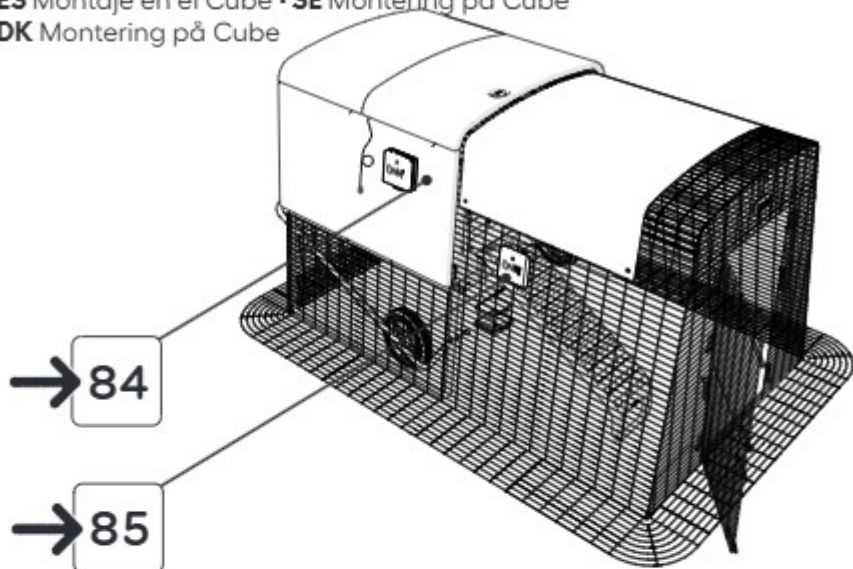

If you haven't removed the roof, you can remove one bolt at the front and pull the corner up to slide the bracket on.



- **DE** Wenn Sie das Dach nicht entfernt haben, können Sie eine Schraube an der Vorderseite des Daches entfernen und die Ecke nach oben ziehen, damit die Halterung aufgeschoben werden kann.
- **FR** Si vous n'avez pas retiré le toit, vous pouvez retirer un boulon à l'avant du toit et tirer le coin vers le haut pour permettre au support de glisser.
- **NL** Als u het dak niet hebt verwijderd, kunt u één bout aan de voorkant van het dak verwijderen en de hoek naar boven trekken zodat de beugel kan schuiven.
- **IT** Se non hai rimosso il tetto, puoi rimuovere un bullone nella parte anteriore del tetto e tirare l'angolo verso l'alto per far scorrere la staffa.
- **ES** Si no ha quitado el tejado, puede quitar un tornillo de la parte delantera y tirar de la esquina hacia arriba para deslizar el soporte.
- **SE** Om du inte har tagit av taket kan du istället ta bort en bult på takets framsida och lyfta upp hörnet för att skjuta in fästet.
- **DK** Hvis du ikke har fjernet taget, kan du fjerne en bolt på forsiden af taget og trække hjørnet op, så beslaget glider på.

84

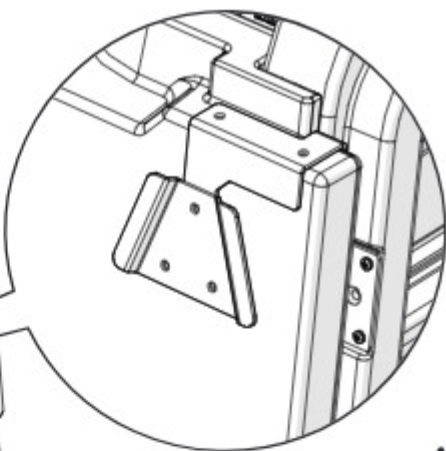
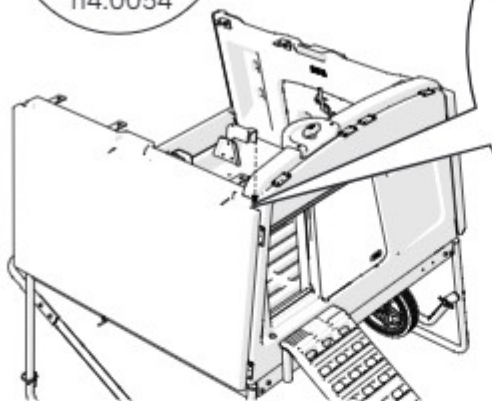

85

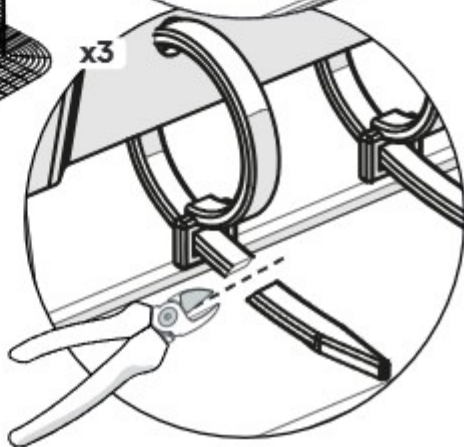
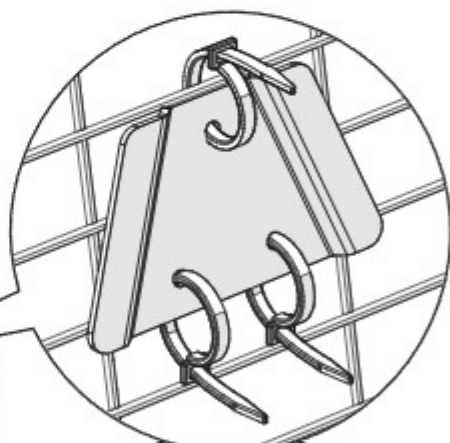
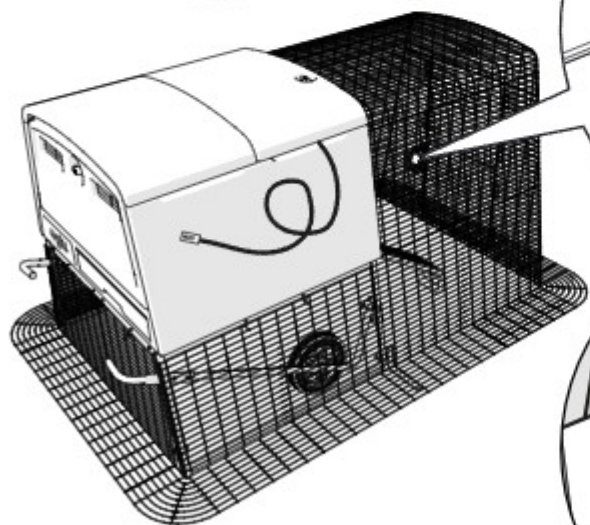

86

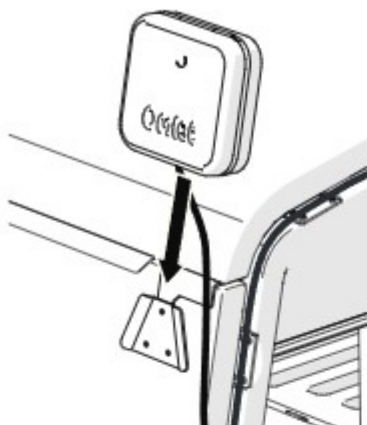

or

oder · ou ·
of · oppure o ·
eller · lub

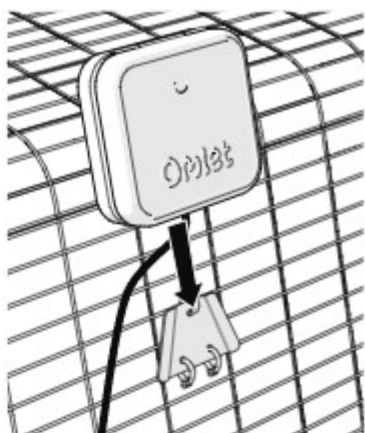

87 Optional



- DE Optional
- FR Facultatif
- NL Optioneel
- IT Opzionali
- SE Valfri
- DK Valgfri



x1

or

oder · ou ·
of · oppure o ·
eller · lub

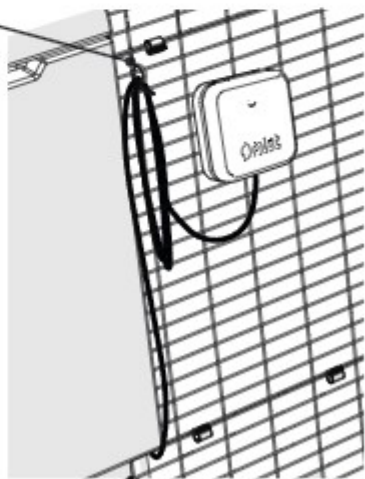
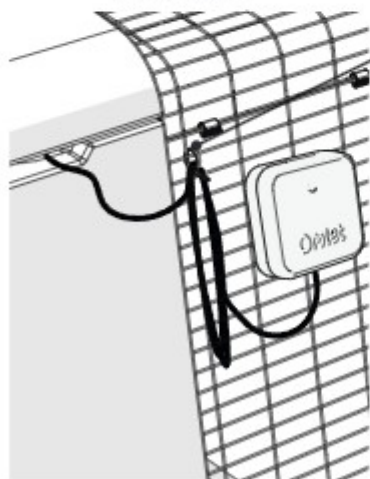

87

83

88 Mounting to the Pro

DE Montage am Eglu Pro • **FR** Montage sur le poulailler Eglu Pro
NL Monteren op Pro • **IT** Montaggio su Eglu Pro • **ES** Montaje en el Pro
SE Montering på Pro • **DK** Montering på Pro

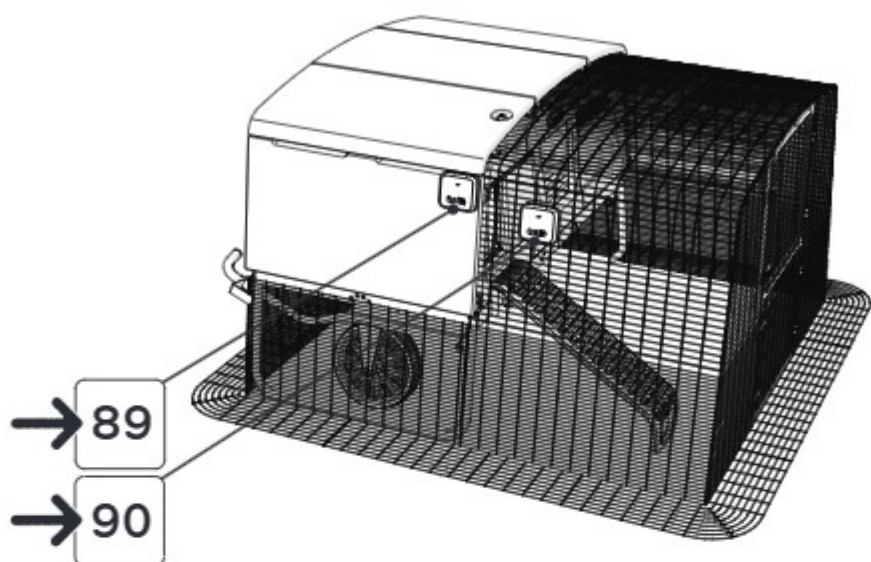

If you haven't removed the roof, you can remove one bolt at the front and pull the corner up to slide the bracket on.



- **DE** Wenn Sie das Dach nicht entfernt haben, können Sie eine Schraube an der Vorderseite des Daches entfernen und die Ecke nach oben ziehen, damit die Halterung aufgeschoben werden kann.
- **FR** Si vous n'avez pas retiré le toit, vous pouvez retirer un boulon à l'avant du toit et tirer le coin vers le haut pour permettre au support de glisser.
- **NL** Als u het dak niet hebt verwijderd, kunt u één bout aan de voorkant van het dak verwijderen en de hoek naar boven trekken zodat de beugel kan schuiven.
- **IT** Se non hai rimosso il tetto, puoi rimuovere un bullone nella parte anteriore del tetto e tirare l'angolo verso l'alto per far scorrere la staffa.
- **ES** Si no ha quitado el tejado, puede quitar un tornillo de la parte delantera y tirar de la esquina hacia arriba para deslizar el soporte.
- **SE** Om du inte har tagit av taket kan du istället ta bort en bult på takets framsida och lyfta upp hörnet för att skjuta in fästet.
- **DK** Hvis du ikke har fjernet taget, kan du fjerne en bolt på forsiden af taget og trække hjørnet op, så beslaget glider på.

89



x1
114.0054

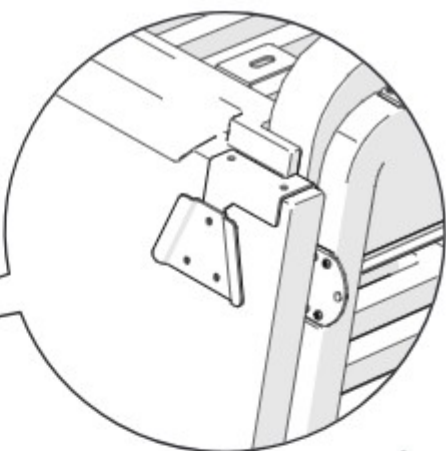
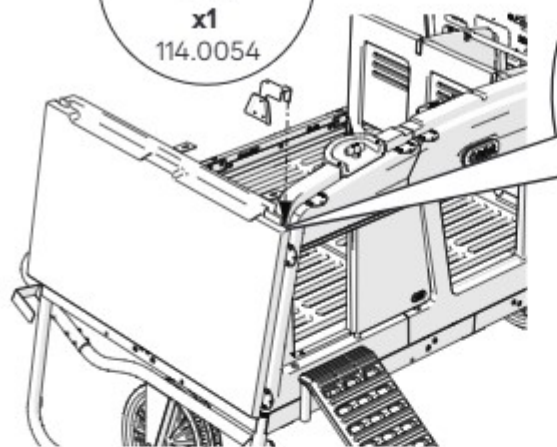

90



x1
014.1135



x3
800.0477

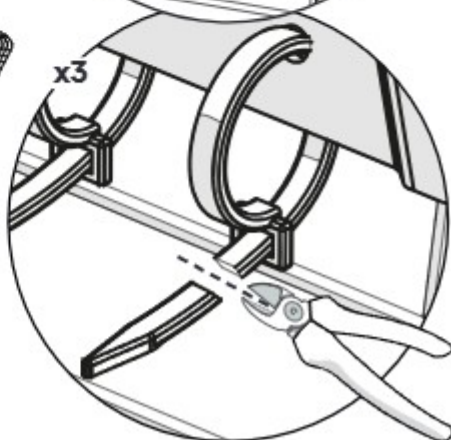
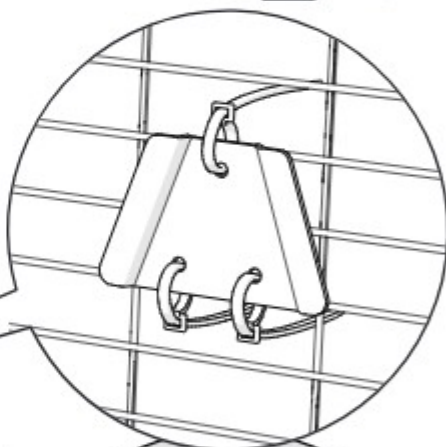
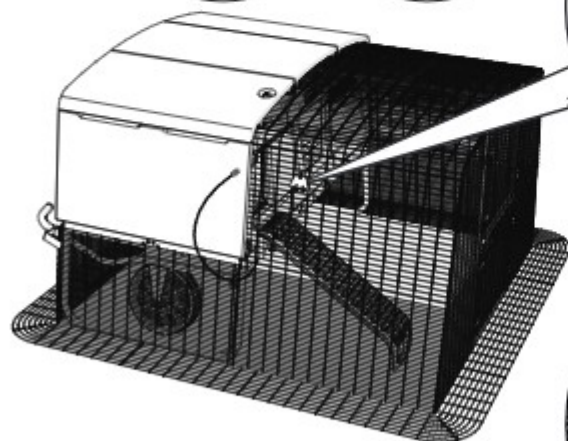

85

91

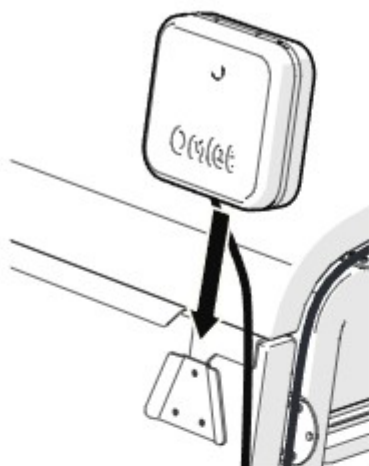

or

oder · ou ·
of · oppure o ·
eller · lub

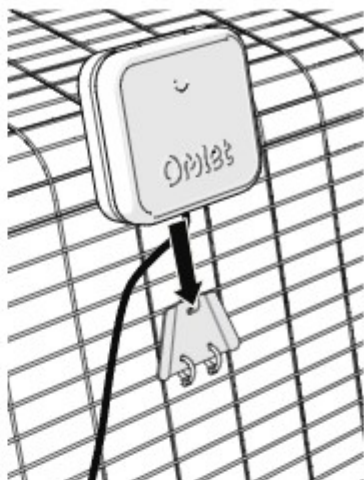

92 Optional



- DE Optional
- FR Facultatif
- NL Optioneel
- IT Opzionali
- SE Valfri
- DK Valgfri

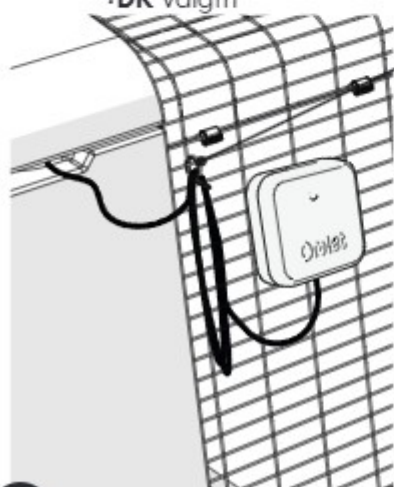

or

oder · ou ·
of · oppure o ·
eller · lub

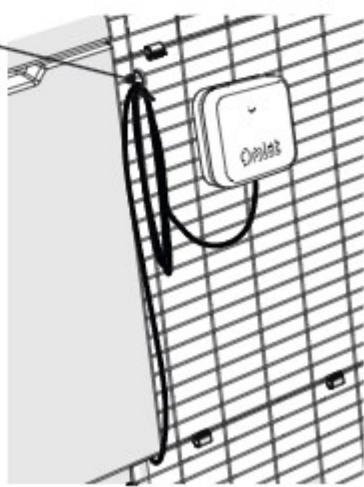

DE Schnellstart-Anleitung • **FR** Guide de démarrage rapide
NL Snelstart handleiding • **IT** Guida Rapida • **ES** Guía rápida de inicio
SE Snabbguide • **DK** Hurtig startvejledning

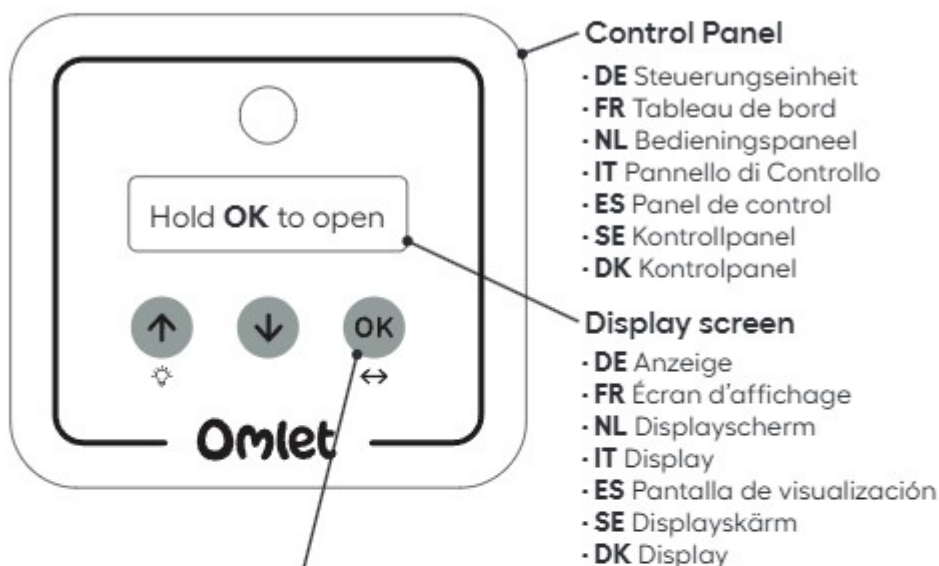
**Control Panel**

- **DE** Steuerungseinheit
- **FR** Tableau de bord
- **NL** Bedieningspaneel
- **IT** Pannello di Controllo
- **ES** Panel de control
- **SE** Kontrollpanel
- **DK** Kontrolpanel

Display screen

- **DE** Anzeige
- **FR** Écran d'affichage
- **NL** Displayscherm
- **IT** Display
- **ES** Pantalla de visualización
- **SE** Displayskärm
- **DK** Display

OK Select / OK button

↔ **Press & Hold to open/
close door**

- **DE** Auswählen / OK Taste; Drücken und gedrückt halten, um die Tür zu öffnen / schließen
- **FR** Bouton SÉLECTION / OK; Appuyez et maintenez pour ouvrir ou fermer la porte
- **NL** Selecteer / OK knop; Houd ingedrukt om de deur te openen/sluiten
- **IT** Seleziona/OK; Tenere premuto per aprire/chiudere la porta
- **ES** Seleccionar / Mantenga pulsado para abrir/cerrar la puerta
- **SE** Välj / OK-knapp; Tryck och håll ner för att öppna/stänga dörren
- **DK** Vælg / OK-knap; Tryk og hold inde for at åbne / lukke døren

Light sensor

- **DE** Lichtsensor
- **FR** Capteur de lumière
- **NL** Lichtsensor
- **IT** Sensore Luminosità
- **ES** Sensor de luz
- **SE** Ljussensor
- **DK** Lyssensor

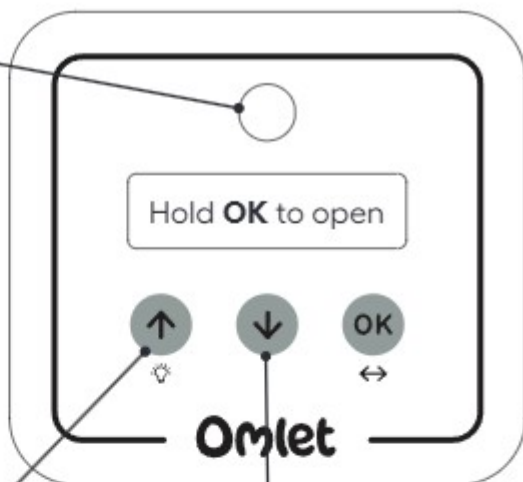

↑ Scroll UP button

💡 Press & Hold to turn optional light on/off

- **DE** Taste zum NACH OBEN scrollen; Drücken und gedrückt halten, um optionales Licht an-/abzuschalten
- **FR** Bouton défiler VERS LE HAUT; Appuyez et maintenez pour allumer ou éteindre l'éclairage optionnel
- **NL** Scroll OMHOOG knop; Houd ingedrukt om de verlichting aan/uit te zetten
- **IT** Pulsante Scorrimento in Alto; Tenere premuto per accendere/spagnere la luce opzionale
- **ES** Botón de desplazamiento hacia ARRIBA; Pulse y mantenga pulsado para encender/apagar la luz opcional
- **SE** UPP-knapp; Tryck och håll ner för att sätta på/stänga av valbart ljus
- **DK** OP-knap; Tryk og hold inde for at tænde / slukke valgfrit lys

↓ Scroll DOWN button

- **DE** Taste zum NACH UNTEN scrollen
- **FR** Bouton DÉFILER VERS LE BAS
- **NL** Scroll OMLAAG-knop
- **IT** Pulsante Scorri in BASSO
- **ES** Botón de desplazamiento hacia ABAJO
- **SE** NEDÅT-knapp
- **DK** NED-knap

DE Steuerung der intelligenten, drehbaren Eglu Autodoor

FR Contrôle de votre Porte Automatique intelligente rotative Eglu

NL Bedienen van de Slimme, roterende Eglu Autodoor

IT Controllare la Smart Autodoor girevole Eglu

ES Manejo de la puerta automática inteligente giratoria Eglu

SE Styr din smarta Autodörr till Eglu-hönshus

DK Styring af din smarte, roterende Eglu Autodoor

EN



page

90

DE



Seite

94

FR



page

102

NL



bladzijde

108

IT



pagina

114

ES



página

120

SE



sida

126

DK



side

132

When connecting to Wi-Fi for smart features or system updates, scan a QR below to download the Omlet App.

DE Wenn Sie eine Verbindung zu Wi-Fi herstellen, um Smart-Funktionen oder Systemupdates zu nutzen, scannen Sie unten einen QR-Code, um die Omlet-App herunterzuladen.

FR Lors de la connexion au Wi-Fi pour des fonctionnalités intelligentes ou des mises à jour système, scannez un QR ci-dessous pour télécharger l'application Omlet.

NL Wanneer u verbinding maakt met wifi voor slimme functies of systeemupdates, scant u een QR-code hieronder om de Omlet-app te downloaden.

IT Quando ti connetti al Wi-Fi per funzionalità intelligenti o aggiornamenti di sistema, scansiona il QR qui sotto per scaricare l'app Omlet.

ES Al conectarse a Wi-Fi para funciones inteligentes o actualizaciones del sistema, escanee el código QR a continuación para descargar la aplicación Omlet.

SE När du ansluter till Wi-Fi för smarta funktioner eller systemuppdateringar, skanna en QR nedan för att ladda ner Omlet-appen.

DK Når du opretter forbindelse til Wi-Fi for at få smarte funktioner eller systemopdateringer, skal du scanne en QR nedenfor for at downloade Omlet-appen.



For Apple



For Android

95 Calibration

When you plug your Smart Rotary Eglu AutoDoor in for the first time, it will need to detect the door position. Press & Hold button. **OK**

The Smart Rotary Eglu AutoDoor will automatically calibrate itself by moving the door once in each direction. Please ensure the Smart Rotary Eglu AutoDoor is not blocked during calibration.

During Calibration the control panel will read:

Calibrating...

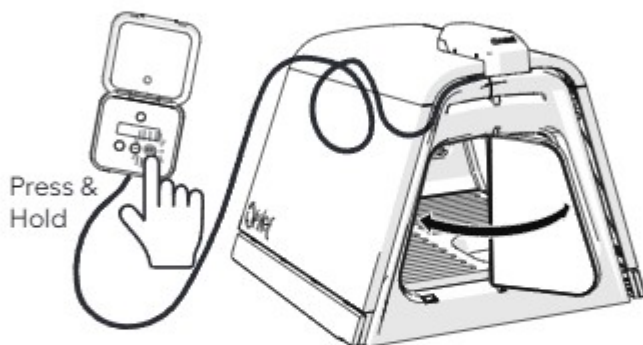

96 Optional: Change Language

1. Press the **↓** button to scroll through the menu until you reach this screen:

Language: En

2. Press & Hold **OK** to enable changing the language. The current language will flash

Language: **En**

3. Use **↑** or **↓** to scroll through the languages until you reach the desired language

Language: **En**

4. Press and hold **OK** to confirm the language update

--Saved--

97 Selecting your Smart Rotary Eglu AutoDoor mode

The Smart Rotary Eglu AutoDoor has 3 modes:

• **MANUAL** - The door will open and close if you Press & Hold  button.

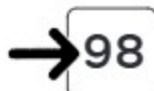



• **TIME** - You can set the Smart Rotary Eglu AutoDoor to open and close at specific times of the day. If you Press & Hold the  button the door will open manually.

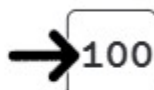

• **LIGHT** - This is the default mode. The Smart Rotary Eglu AutoDoor will open using the light sensor. If you Press & Hold the  button the door will open manually.





98 Manual Mode

Press any of the three buttons    and the screen will read:

Hold to Open

Hold to Close

Hold the  button to either open or close the door.

To proceed through the menu press   to scroll up & down through the menu items.

In the Manual Mode menu you see the following:

Hold to Open

This displays the battery charge level.

Battery: 100%

This displays the current Mode setting.

1. Mode: Manual

This gives you the option to reset the Control Pack back to its default settings following any changes you make.

5. Factory Reset

99 Time Mode

The Automatic Door uses the 24-hour clock, to prevent any ambiguity. The time is reset when the batteries are removed or a power outage occurs during mains operation. If the door is not connected to the Wi-Fi, it automatically switches to light mode. The mode and time must then be reset manually.



Setting the Mode

1. Press for a short time to scroll through the options until you reach the mode
2. Press & Hold to enable changing the value. The current mode will flash
3. Use to scroll through the modes
4. Press & Hold to confirm the value change

1. Mode: Manual

1. Mode: Manual

1. Mode: Manual

1. Mode: Time

--Saved--

Setting the Current Time

1. Press for a short time to scroll through the options until you reach the mode menu item
2. Press & Hold until the minutes begin to flash
3. Press or to set the minutes
4. Press to switch to hours which will flash to confirm they are selected
5. Press or to set the hours
6. Press & Hold to confirm. The display will read -saved-

2. Time: 14:23

2. Time: 14:-23-









2. Time: 14:-05-

2. Time: -14-:05

2. Time: -18-:05

--Saved--

Setting the Opening Time

1. Press  for a short time to scroll through the options you reach the display on the right
2. Press & Hold  until the minutes begin to flash
3. Press  or  to set the minutes
4. Press  to switch to hours which will flash to confirm they are selected
5. Press  or  to set the hours
6. Press & Hold  to confirm.

3. Open @ 01:00

3. Open @ 01:00









3. Open @ 01:30

3. Open @ 01:30

3. Open @ 08:30

--Saved--

Setting the Closing Time

1. Press  for a short time to scroll through the options you reach the display on the right
2. Press & Hold  until the minutes begin to flash
3. Press  or  to set the minutes
4. Press  to switch to hours which will flash to confirm they are selected
5. Press  or  to set the hours
6. Press & Hold  to confirm.

4. Close @ 01:00

4. Close @ 01:00

4. Close @ 01:15

4. Close @ 01:15

4. Close @ 19:15

--Saved--

100 Light Mode



If the light level where the control panel is located changes frequently (busy neighbourhood) light mode may not function as expected - please switch to Time Mode.

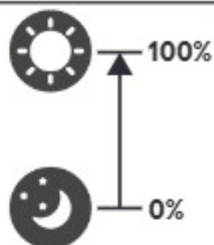

Setting the Mode

1. Press for a short time to scroll through the options until you reach the mode
2. Press & Hold to enable changing the value. The current mode will flash
3. Use to scroll through the modes
4. Press & Hold to confirm the value change

1. Mode: Manual

1. Mode: Manual

1. Mode: Manual

1. Mode: Light

--Saved--

Setting the Light Opening Level



The door opening light level should be set to a higher percentage than the door closing light level. The two values should at least be 10% apart from each other. We recommend starting with 13 and 3, then adjust to suit as the location of the coop can effect the light levels. Adjustments may be needed with the change of seasons.

1. Press for a short time to scroll through the options until you reach the display on the right
2. Press & Hold until the numbers begin to flash
3. Press or to set the level
4. Press & Hold to confirm

3. Open @ 27

3. Open @ 27

3. Open @ 13

--Saved--

Setting the Light Closing Level

1. Press  for a short time to scroll through the options until you reach the display on the right

4. Close @ 6

2. Press & Hold  until the numbers begin to flash

4. Close @ 6

3. Press  or  to set the level

4. Close @ 3

4. Press & Hold  to confirm

--Saved--

Setting the Open Delay



The autodoor has a default factory delay set at 20 minutes after the light reaches the required level. You cannot go below 20 minutes and can only manually set additional delay minutes. This is in order to prevent any accidental opening or closing of the door when the light level changes for short periods of time, e.g. if a car drove past with headlights on.

1. Press  for a short time to scroll through the options until you reach the display on the right

5. Open Delay 0m

2. Press & Hold  until the numbers begin to flash

5. Open Delay 0m

3. Press  or  to set the minutes

5. Open Delay 7m

4. Press & Hold  to confirm

--Saved--

Setting the Close Delay



Same principle as at opening delay - See above.

1. Press  for a short time to scroll through the options until you reach the display on the right

6. Close Delay 0m

2. Press & Hold  until the numbers begin to flash

6. Close Delay 0m

3. Press  or  to set the minutes

6. Close Delay 10m

4. Press & Hold  to confirm

--Saved--

95 Kalibration

Wenn Sie Ihre intelligente, drehbare Eglu Autodoor zum ersten Mal anschließen, muss sie die Türposition erkennen. Drücken und halten Sie dazu die **OK** Taste gedrückt.

Die intelligente, drehbare Eglu Autodoor kalibriert sich automatisch, indem sie die Tür einmal in jede Richtung bewegt. Bitte stellen Sie sicher, dass die intelligente, drehbare Eglu Autodoor während der Kalibrierung nicht blockiert ist.

Während der Kalibrierung wird auf dem Bedienfeld folgendes angezeigt:

Calibrating...



96 Sprache ändern

1. Drücken Sie die Taste **↓** um durch das Menü zu scrollen, bis Sie diesen Bildschirm erreichen:

Language: En

2. Drücken und Halten Sie **OK** um die Änderung der Sprache zu ermöglichen. Die aktuelle Sprache wird blinken.

Language: **En**

3. Scrollen Sie mit **↑** oder **↓** durch die Sprachen, bis Sie die gewünschte Sprache erreicht haben.

Sprache: **De**

4. Drücken und Halten Sie **OK** um die Aktualisierung der Sprache zu bestätigen.

--Gespeichert--

Die Wahl des Modus für Ihre intelligente, drehbare Eglu Autodoor?

Die Intelligente Drehbare Eglu Autodoor hat 3 Modi:

• MANUELL – Die Tür öffnet und schließt sich, wenn die  Taste gedrückt gehalten wird.





• ZEIT – Die Intelligente Drehbare Eglu Autodoor kann so eingestellt werden, dass sie sich zu bestimmten Zeiten des Tages öffnet und schließt. Wenn Sie die  Taste gedrückt halten, wird die Tür manuell geöffnet.

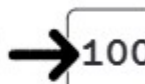

• LICHT – Dies ist der Standardmodus. Die Intelligente Drehbare Eglu Autodoor öffnet sich mittels des Lichtsensors. Wenn Sie die  Taste gedrückt halten, wird die Tür manuell geöffnet.



98 Manueller Modus

Drücken Sie einen der drei Knöpfe    und auf der Anzeige wird zu lesen sein:

Halten → Schließt

oder

Halten → Öffnet

Halten Sie die  Taste gedrückt, um die Tür zu öffnen oder zu schließen.

Um durch das Menü zu scrollen, verwenden Sie die   Tasten.

Im manuellen Modus sehen Sie folgendes:

Halten → Schließt

Wie voll / leer die Batterie ist.

Batterie: 100%

Der aktuelle Modus

1. Modus: Manuell

Hier können Sie das Steuerungselement auf Werkeinstellungen zurücksetzen

5. Werksreset



Die Intelligente Autodoor verwendet der Deutlichkeit halber die 24-Stunden-Uhr. Die Uhrzeit wird zurückgesetzt, wenn die Batterien entfernt werden oder wenn während des Netzbetriebs ein Stromausfall auftritt. Ist die Tür nicht mit dem WLAN verbunden, wechselt sie automatisch in den Lichtmodus. Modus und Uhrzeit müssen dann manuell wieder eingestellt werden.

Den Modus einstellen

1. Drücken Sie kurzzeitig um die Modusanzeige im Menü zu finden

1.Modus: Manuell

2. Drücken und halten Sie gedrückt, um den Modus zu ändern. Der aktuelle Modus wird aufblinken

1.Modus: Manuell

3. Nutzen Sie um durch die Modi zu gehen

1.Modus: Manuell

1.Modus: Zeit

4. Drücken und halten Sie gedrückt, um die Änderung zu bestätigen

--Gespeichert--

Einstellen der aktuellen Uhrzeit

1. Drücken Sie kurzzeitig bis Sie Zeit erreicht haben

2. Zeit: 14:23

2. Drücken und halten Sie bis die Minuten anfangen zu blinken

2. Zeit: 14: 23

3. Drücken Sie oder um die Minuten einzustellen

2. Zeit: 14: 05

4. Drücken Sie um zu den Stunden zu wechseln. Sie blinken, wenn sie ausgewählt sind

2. Zeit: 14 :05

5. Drücken Sie oder um die Stunden einzustellen

2. Zeit: 18 :05

6. Drücken und halten Sie gedrückt, um zu bestätigen. Auf der Anzeige wird nun zu sehen sein: --Gespeichert--

--Gespeichert--

Die Öffnungszeit einstellen

1. Drücken Sie kurzzeitig  bis Sie die Anzeige rechts erreicht haben

3. Öffnen @ 01:00

2. Drücken und halten Sie  bis die Minuten anfangen zu blinken

3. Öffnen @ 01:-00

3. Drücken Sie  oder  um die Minuten einzustellen

3. Öffnen @ 01:-30

4. Drücken Sie  um zu den Stunden zu wechseln. Sie blinken, wenn sie ausgewählt sind

3. Öffnen @ -01:-30

5. Drücken Sie  oder  um die Stunden einzustellen

3. Öffnen @ -08:-30

6. Zur Bestätigung gedrückt halten 

--Gespeichert--

Schließzeit einstellen

1. Drücken Sie kurzzeitig  bis Sie die Anzeige rechts erreicht haben

4. Schließen @ 01:00

2. Drücken und halten Sie  bis die Minuten anfangen zu blinken

4. Schließen @ 01:-00

3. Drücken Sie  oder  um die Minuten einzustellen

4. Schließen @ 01:-15

4. Drücken Sie  um zu den Stunden zu wechseln. Sie blinken, wenn sie ausgewählt sind

4. Schließen @ -01:-15

5. Drücken Sie  oder  um die Stunden einzustellen

4. Schließen @ -19:-15

6. Zur Bestätigung gedrückt halten 

--Gespeichert--

100 Lichtmodus



Wenn sich das Lichtniveau an der Stelle, an der sich das Bedienfeld befindet, häufig ändert (z.B. in verkehrsreicher Umgebung), funktioniert der Lichtmodus möglicherweise nicht wie erwartet - schalten Sie in diesem Fall bitte auf den Zeitmodus um.

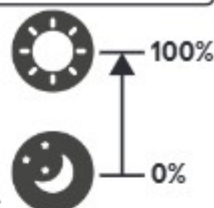

Den Modus einstellen

1. Drücken Sie kurzzeitig um den richtigen Modus im Menü zu finden
2. Drücken und halten Sie gedrückt, um den Modus zu ändern. Der aktuelle Modus wird aufblinken
3. Nutzen Sie um durch die Modi zu gehen
4. Drücken und halten Sie gedrückt, um die Änderung zu bestätigen

1. Modus: Manuell

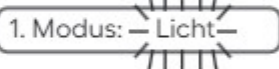
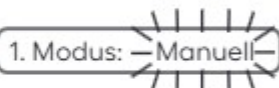
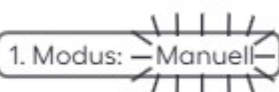

--Gespeichert--

Die Lichtempfindlichkeit für die Türöffnung einstellen



Der Wert der Lichtintensität für das Öffnen der Tür muss höher eingestellt sein als der Wert der Lichtintensität für das Schließen der Tür. Die beiden Werte sollten mindestens 10% auseinander liegen. Wir empfehlen, mit den Werten 13 und 3 zu beginnen und sie dann entsprechend anzupassen, da der Standort des Hühnerstalls die Lichtverhältnisse beeinflussen kann. Anpassungen können auch mit dem Wechsel der Jahreszeiten erforderlich werden

1. Drücken Sie kurzzeitig bis Sie die Anzeige rechts erreicht haben
2. Drücken und halten Sie bis die Zahlen anfangen zu blinken
3. Drücken Sie oder um das Lichtniveau einzustellen
4. Zur Bestätigung gedrückt halten

3. Öffnen @ 27



--Gespeichert--

Die Lichtempfindlichkeit für die Türschließung einstellen

1. Drücken Sie kurzzeitig  bis Sie die Anzeige rechts erreicht haben

4. Schließen @ 6

2. Drücken und halten Sie  bis die Zahlen anfangen zu blinken

4. Schließen @ - 6 -

3. Drücken Sie  oder  um das Lichtniveau einzustellen

4. Schließen @ - 3 -

4. Zur Bestätigung gedrückt halten 

--Gespeichert--

Öffnungsverzögerung einstellen



Die Werkseinstellung der Tür ist auf eine Verzögerung von 20 Minuten, nachdem das Lichtniveau den erforderlichen Wert erreicht hat, fixiert. Sie können diese 20 Minuten nicht unterschreiten und daher nur zusätzliche Minuten Verzögerung manuell einstellen. Dies ist erforderlich, um ein versehentliches Öffnen oder Schließen der Tür zu verhindern, sollte sich das Lichtniveau kurzzeitig ändern, z. B. falls ein Auto mit eingeschalteten Scheinwerfern vorbeifährt.

1. Drücken Sie kurzzeitig  bis Sie die Anzeige rechts erreicht haben

5. Öffnungsverzögerung 0m

2. Drücken und halten Sie  bis die Zahlen anfangen zu blinken

5. Öffnungsverzögerung - 0m -

3. Drücken Sie  oder  um das Lichtniveau einzustellen

5. Öffnungsverzögerung - 7m -

4. Zur Bestätigung gedrückt halten 

--Gespeichert--

Schließverzögerung einstellen



Gleiches Prinzip wie bei einer Öffnungsverzögerung – siehe oben.

1. Drücken Sie kurzzeitig  bis Sie die Anzeige rechts erreicht haben

6. Schließverzögerung 0m

2. Drücken und halten Sie  bis die Zahlen anfangen zu blinken

6. Schließverzögerung - 0m -

3. Drücken Sie  oder  um das Lichtniveau einzustellen

6. Schließverzögerung - 10m -

4. Zur Bestätigung gedrückt halten 

--Gespeichert--

95 Calibrage

Lorsque vous branchez votre Porte Automatique intelligente rotative Eglu pour la première fois, le boîtier doit détecter la position de la porte. Appuyez longuement sur le bouton **OK**

La Porte Automatique intelligente rotative Eglu se calibre automatiquement en se déplaçant une fois dans chaque direction. Veillez à ce que la Porte Automatique ne soit pas bloquée pendant le calibrage.

Lors du processus de calibrage, le tableau de bord affichera le message suivants :

Calibrating...

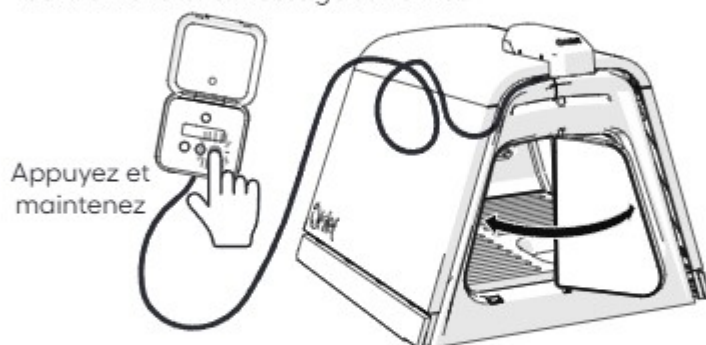

96 Changer la langue

1. Appuyez sur le bouton **↓** pour défiler dans le menu jusqu'à cet écran :

Language: En

2. Gidez **OK** appuyé pour changer la langue. La langue actuelle clignotera

Language: **En**

3. Utilisez **↑** ou **↓** pour choisir la langue

Language: **Fr**

4. Gardez **OK** appuyé pour confirmer la langue

--Enregistré--

Sélection du mode de votre Porte Automatique intelligente rotative Eglu?

La Porte Automatique intelligente rotative Eglu dispose de 3 modes :

• MANUEL – La porte s'ouvre et se ferme lorsque vous maintenez le bouton **OK** enfoncé.

→ 98



• HORAIRE – Vous pouvez programmer la porte automatique intelligente Eglu pour qu'elle s'ouvre et se ferme à des heures précises de la journée. Si vous maintenez le bouton **OK** enfoncé, la porte s'ouvrira manuellement.

→ 99

• LUMINOSITÉ – Il s'agit du mode par défaut. La porte automatique intelligente Eglu s'ouvre grâce à un capteur de luminosité. Si vous maintenez le bouton **OK** enfoncé, la porte s'ouvrira manuellement.

→ 100



98 Mode manuel

Appuyez sur l'un des trois boutons.   
L'écran affichera :

Tenir pr Ouvrir

Tenir pr Fermer

Appuyez et maintenez la touche **OK** pour ouvrir ou fermer la porte

Pour parcourir le menu, appuyez sur  
pour faire défiler les rubriques

Dans le menu du mode MANUEL, vous verrez ceci :

Tenir pr Ouvrir

Ceci vous indique la charge de la batterie :

Batterie: 100%

Ceci vous montre le mode actuellement utilisé :

1. Mode: Manuel

Ceci vous permet de rétablir les réglages d'origine et annulera tout changement effectué :

5. Param. Usine

99 Mode horaire

La Porte Automatique intelligente utilise le format 24 heures afin d'éviter toute ambiguïté. L'heure est réinitialisée lorsque les piles sont retirées ou une panne de courant se produit lors de l'utilisation de l'adaptateur secteur. Si la porte n'est pas connectée au Wi-Fi, elle passe automatiquement en mode luminosité. Le mode et l'heure doivent ensuite être réinitialisés manuellement.



Activer le mode

1. Appuyez sur sans le maintenir enfoncé pour faire défiler le menu jusqu'au mode de votre choix

1. Mode: Manuel

2. Appuyez et maintenez pour pouvoir changer de mode. Le mode actuellement utilisé s'affichera en clignotant

1. Mode: Manuel

3. Utilisez pour naviguer dans le menu

1. Mode: Manuel

1. Mode: Heure

4. Appuyez et maintenez pour valider votre

--Enregistré--

Paramétrer l'horaire

1. Appuyez sur sans le maintenir enfoncé jusqu'à atteindre le menu

2. Heure: 14:23

2. Appuyez et maintenez jusqu'à voir les minutes clignoter

2. Heure: 14:-23-

3. Utilisez et pour modifier les minutes

2. Heure: 14:-05-

4. Appuyez sur pour passer au réglage des heures qui clignoteront lorsqu'elles seront sélectionnées

2. Heure: -14 -05

5. Utilisez et pour modifier les heures

2. Heure: -18 -05

6. Appuyez longuement sur pour valider. L'écran affichera -Enregistré-

--Enregistré--

Réglage de l'heure d'ouverture de la porte

1. Appuyez sur  sans le maintenir enfoncé jusqu'à atteindre le menu affiché ci-contre :

3. Ouvre @ 01:00

2. Appuyez et maintenez  jusqu'à ce que les minutes clignotent

3. Ouvre @ 01:-00-

3. Appuyez sur  ou  pour régler les minutes

3. Ouvre @ 01:-30-

4. Appuyez sur  pour passer au réglage des heures qui clignoteront lorsqu'elles seront sélectionnées

3. Ouvre @-01:-30

5. Appuyez sur  ou  pour régler les heures

3. Ouvre @-08:-30

6. Appuyez longuement sur  pour valider

--Enregistré--

Réglage de l'heure de fermeture de la porte

1. Appuyez sur  sans le maintenir enfoncé jusqu'à atteindre le menu affiché ci-contre :

4. Ferme @ 01:00

2. Appuyez et maintenez  jusqu'à ce que les minutes clignotent

4. Ferme @ 01:-00-

3. Appuyez sur  ou  pour régler les minutes

4. Ferme @ 01:-15-

4. Appuyez sur  pour passer au réglage des heures qui clignoteront lorsqu'elles seront sélectionnées

4. Ferme @-01:-15

5. Appuyez sur  ou  pour régler les heures

4. Ferme @-19:-15

6. Appuyez longuement sur  pour valider

--Enregistré--

100 Mode luminosité



Si la luminosité vers le tableau de bord change fréquemment, le capteur de luminosité risque de ne pas fonctionner comme prévu. Veuillez alors utiliser le mode horaire

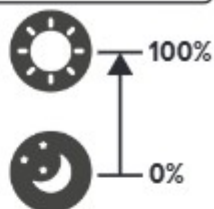

Activer le mode

1. Appuyez sur sans le maintenir enfoncé jusqu'à atteindre le menu de sélection des modes
2. Appuyez et maintenez pour pouvoir changer de mode. Le mode actuellement utilisé s'affichera en clignotant
3. Utilisez pour naviguer dans le menu
4. Appuyez et maintenez pour valider votre modification

1. Mode: Manuel

1. Mode: Manuel

1. Mode: Manuel

1. Mode: Luminosité

--Enregistré--

Choisir le niveau de luminosité pour



Le niveau de lumière lors de l'ouverture de la porte doit être réglé plus fort que le niveau de lumière lors de la fermeture de la porte. Ces deux valeurs doivent avoir une différence entre elles d'au moins 10 %. Nous vous recommandons au début de régler les niveaux de lumière sur 13 et 3, puis de les ajuster en fonction de l'emplacement du poulailler. Des ajustements peuvent être nécessaires avec les changements de saisons

1. Appuyez sur sans le maintenir enfoncé jusqu'à atteindre le menu affiché ci-contre :
2. Appuyez et maintenez jusqu'à ce que les chiffres clignotent
3. Appuyez sur ou pour régler le niveau
4. Appuyez longuement sur pour valider

3. Ouvre @ 27

3. Ouvre @ 27

3. Ouvre @ 13

--Enregistré--

Choisir le niveau de luminosité pour la fermeture de la porte

1. Appuyez sur  sans le maintenir enfoncé jusqu'à atteindre le menu affiché ci-contre :

4. Ferme @ 6

2. Appuyez et maintenez  jusqu'à ce que les chiffres clignotent

4. Ferme @  6

3. Appuyez sur  ou  pour régler le niveau

4. Ferme @  3

4. Appuyez longuement sur  pour valider

--Enregistré--

Réglage du délai d'ouverture de la porte



Par défaut, la porte automatique s'ouvre ou se ferme 20 minutes après que la luminosité requise soit atteinte. Vous pouvez augmenter ce délai mais vous ne pourrez pas aller en dessous de 20 minutes. Ceci est prévu pour éviter des ouvertures ou fermetures accidentelles si le capteur de lumière se trouve éclairé ou obstrué pendant une courte période, par exemple si une voiture passe avec ses phares allumés.

1. Appuyez sur  sans le maintenir enfoncé jusqu'à atteindre le menu affiché ci-contre :

5. Délai Ouverture 0m

2. Appuyez et maintenez  jusqu'à voir les chiffres clignoter

5. Délai Ouverture  0m

3. Appuyez sur  ou  pour modifier les minutes

5. Délai Ouverture  7m

4. Appuyez longuement sur  pour valider.

--Enregistré--

Réglage du délai de fermeture de la porte



Même principe que pour le délai d'ouverture – Voir ci-dessus.

1. Appuyez sur  sans le maintenir enfoncé jusqu'à atteindre le menu affiché ci-contre :

6. Délai Fermeture 0m

2. Appuyez et maintenez  jusqu'à voir les chiffres clignoter

6. Délai Fermeture  0m

3. Appuyez sur  ou  pour modifier les minutes

6. Délai Fermeture  10m

4. Appuyez longuement sur  pour valider.

--Enregistré--

95 Afstellen

Als u de Slimme roterende Eglu Autodoor voor het eerst aansluit, moet de deurpositie gedetecteerd worden. Houd de **OK** knop ingedrukt.

De Slimme, roterende Eglu Autodoor zal zichzelf automatisch kalibreren door de deur eenmaal in elke richting te bewegen. Zorg ervoor dat de Slimme Autodoor tijdens het kalibreren niet wordt geblokkeerd.

Tijdens het kalibreren geeft het bedieningspaneel het volgende weer:

Calibrating...

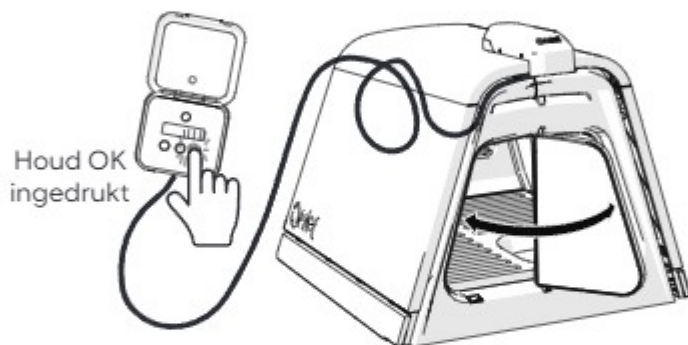

96 Taal wijzigen

1. Druk op de **↓** knop om door het menu te scrollen totdat u dit scherm bereikt:

Language: En

2. Houd **OK** ingedrukt om de taal te wijzigen. De huidige taal zal knipperen

Language: **En**

3. Gebruik **↑** of **↓** om door de talen te scrollen totdat u de gewenste taal bereikt

Taal: **NL**

4. Houd **OK** ingedrukt om de geselecteerde taal te bevestigen

--Opgeslagen--

De modus voor de Slimme, roterende Eglu Autodoor kiezen?

De Slimme Draaiende Eglu Autodoor heeft 3 standen:

• **HANDMATIG** - De deur gaat open en dicht als je de **OK** knop ingedrukt houdt.

→ 98

• **TIJD** - Je kunt de Slimme Draaiende Eglu AutoDoor instellen om op bepaalde tijden van de dag te openen en te sluiten.

Als je de **OK** knop ingedrukt houdt, gaat de deur handmatig open.

→ 99

• **LICHT** - Dit is de standaardmodus. De Slimme Draaiende Eglu AutoDoor gaat open met behulp van de lichtsensoren. Als je de **OK**

→ 100

98 Manual-mode

Druk op de **↑ ↓ OK** knop en op het scherm verschijnt

Druk voor Open

Druk voor Sluit

Houd de **OK** knop ingedrukt om de deur te openen of sluiten.

Druk om het menu te doorlopen **↑ ↓**

In het Manual-mode menu ziet u:

Druk voor Open

Dit geeft het batterijpercentage weer:

Batterij: 100%

Dit geeft de stand-instelling weer:

1. Modus: Manueel

Dit geeft u de mogelijkheid de bedieningsinstellingen terug te zetten naar de standaardinstellingen na elke wijziging die u heeft gemaakt.

5. Factory Reset

99 Time-mode



De Smart Autodoor voor de Eglu gebruikt de 24-uurs klok, om onduidelijkheid te voorkomen. De tijd wordt gereset wanneer de batterijen worden verwijderd of wanneer er een stroomstoring optreedt tijdens netvoeding. Als de deur niet is verbonden met wifi, schakelt hij automatisch over naar de Daglicht-mode. De modus en tijd moeten dan handmatig worden gereset.

De mode instellen

1. Houd kort ingedrukt om de opties te doorlopen totdat u de mode heeft bereikt

1.Modus: Manueel

2. Houd ingedrukt om de mode aan te passen. De huidige mode zal gaan knipperen

1.Modus: Manueel

3. Gebruik om door de modes te scrollen

1.Modus: Manueel

1. Modus: Tijd

4. Houd ingedrukt om de aanpassing van de mode te bevestigen

--Opgeslagen--

Tijd instellen

1. Houd kort ingedrukt om naar het mode-menu te gaan

2. Tijd: 14:23

2. Houd ingedrukt totdat de minuten gaan knipperen

2. Tijd: 14: 23

3. Druk of om de minuten in te stellen

2. Tijd: 14: 05

4. Druk om de uren te selecteren. Deze gaan ter bevestiging knipperen.

2. Tijd: 14 :05

5. Druk of om de uren in te stellen

2. Tijd: 18 :05

6. Druk om te bevestigen.
Op het scherm verschijnt -Opgeslagen-

--Opgeslagen--

Instellen van de openingstijd

1. Houd  kort ingedrukt om het scherm rechts te bereiken

3. Open @ 01:00

2. Houd  ingedrukt totdat de minuten gaan knippen

3. Open @ 01:-00-

3. Druk  of  om de minuten in te stellen

3. Open @ 01:-30-

4. Druk  om de uren te selecteren. Deze gaan ter bevestiging knippen

3. Open @ -01:-30

5. Druk  of  om de uren in te stellen

3. Open @ -08:-30

6. Houd  ingedrukt om te bevestigen.

--Opgeslagen--

Instellen van de sluitingstijd

1. Houd  kort ingedrukt om het scherm rechts te bereiken

4. Sluit @ 01:00

2. Houd  ingedrukt totdat de minuten gaan knippen

4. Sluit @ 01:-00-

3. Druk  of  om de minuten in te stellen

4. Sluit @ 01:-15-

4. Druk  om de uren te selecteren. Deze gaan ter bevestiging knippen

4. Sluit @ -01:-15

5. Druk  of  om de uren in te stellen

4. Sluit @ -19:-15

6. Houd  ingedrukt om te bevestigen.

--Opgeslagen--

100 Daglicht-mode



Wanneer het lichtniveau op de plek waar het bedieningspaneel zicht bevindt regelmatig wijzigt (bijvoorbeeld in een drukke omgeving), functioneert de Light modus mogelijk niet naar verwachting - schakel in dit geval over naar de Time modus.

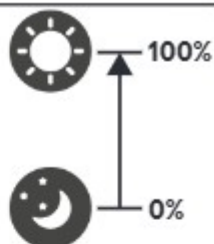

De mode instellen

1. Houd kort ingedrukt om de opties te doorlopen totdat u de mode heeft bereikt
2. Houd ingedrukt om de mode aan te passen. De huidige mode zal gaan knippen
3. Gebruik om door de modes te scrollen
4. Houd ingedrukt om de aanpassing van de mode te bevestigen

1.Modus: Manueel

1.Modus: Manueel

1.Modus: Manueel

1. Modus: Licht

--Opgeslagen--

Instellen van het lichtniveau voor openen



Het lichtniveau waarop de deur opent moet op een hoger percentage worden ingesteld dan het lichtniveau waarop de deur sluit. De twee waarden moeten minimaal 10% bij elkaar vandaan liggen. We raden aan om te beginnen met 13% en 3% en de waarden indien nodig aan te passen. Dit omdat de locatie van het kippenhok van invloed kan zijn op het lichtniveau. Het kan nodig zijn deze waarden aan te passen, afhankelijk van het seizoen

1. Houd kort ingedrukt om het scherm rechts te bereiken
2. Houd ingedrukt totdat de cijfers gaan knippen
3. Druk of om het lichtniveau in te stellen
4. Houd ingedrukt om te bevestigen.





3. Open @ 27

3. Open @ 27

3. Open @ 13

--Opgeslagen--

Instellen van het lichtniveau voor sluiten

1. Houd  kort ingedrukt om het scherm rechts te bereiken
2. Houd  ingedrukt totdat de cijfers gaan knipperen
3. Druk  of  om het lichtniveau in te stellen
4. Houd  ingedrukt om te bevestigen.

4. Sluit @ 6

4. Sluit @ 6





4. Sluit @ 3

--Opgeslagen--

Instellen van de open-vertraging



Als standaardinstelling sluit de autodoor met een vertraging van 20 minuten nadat het ingestelde lichtniveau is bereikt. Het is niet mogelijk deze tijd te verkorten en er kunnen alleen manueel minuten aan worden toegevoegd. Dit is om te voorkomen dat de deur onbedoeld opent of sluit wanneer het lichtniveau tijdelijk wijzigt, bijvoorbeeld wanneer een auto met koplampen aan langsrijdt.

1. Houd  kort ingedrukt om het scherm rechts te bereiken
2. Houd  ingedrukt totdat de cijfers gaan knipperen
3. Druk  of  om de minuten in te stellen
4. Houd  ingedrukt om te bevestigen.

5. Open Vertraging 0m

5. Open Vertraging 0m





5. Open Vertraging 7m

--Opgeslagen--

Sluitingsvertraging instellen



Dezelfde principes zijn van toepassing bij vertragingen in het openen - zie hierboven.

1. Houd  kort ingedrukt om het scherm rechts te bereiken
2. Houd  ingedrukt totdat de cijfers gaan knipperen
3. Druk  of  om de minuten in te stellen
4. Houd  ingedrukt om te bevestigen.

6. Sluit Vertraging 0m

6. Sluit Vertraging 0m

6. Sluit Vertraging 10m

--Opgeslagen--

95 Calibrazione

Quando la Smart Autodoor girevole Eglu viene collegata per la prima volta, dovrà rilevare la posizione della porta

Tenete premuto il pulsante **OK**

La Smart Autodoor girevole Eglu si calibrerà automaticamente muovendosi una volta in ciascuna direzione. Assicurarsi che la porta automatica non sia bloccata durante la calibrazione.

Durante la calibrazione sul pannello di controllo si leggerà:

Calibrating...

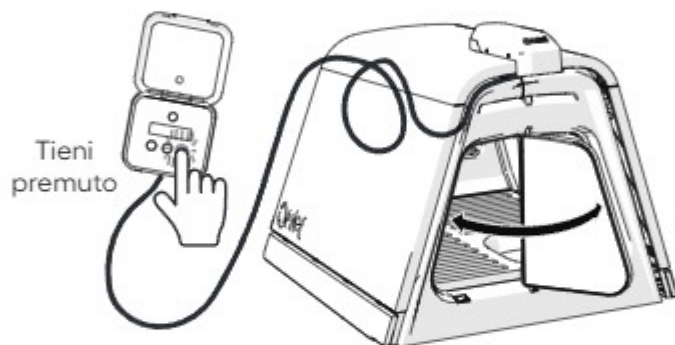

96 Cambio lingua

1. Premere **↓** per scorrere il menu fino a raggiungere questa schermata:

Language: En

2. Premere e tenere premuto **OK** per modificare la lingua. La lingua corrente lampeggerà

Language: **En**

3. Utilizzare **↑** o **↓** per scorrere le lingue finché non avrete trovato quella desiderata

Lingua: **It**

4. Premete e tenete premuto **OK** per confermare l'aggiornamento della lingua

--Salvato--

Selezionare la modalità della Smart Autodoor girevole Eglu?

La porta automatica girevole Eglu Smart ha 3 modalità:

• **MANUALE** - La porta si apre e si chiude tenendo premuto il pulsante **OK**





• **TEMPO** - È possibile programmare l'apertura e la chiusura della porta automatica girevole Eglu Smart a orari specifici della giornata. Tenendo premuto il pulsante **OK** la porta si aprirà manualmente.



• **LUMINOSITÀ** - Questa è la modalità predefinita. La porta automatica girevole Eglu Smart si apre tramite un sensore di luminosità. Tenendo premuto il pulsante **OK** la porta si aprirà manualmente.



98 Modalità manuale

Premete uno qualsiasi dei pulsanti   **OK** e sullo schermo apparirà:

Premi → Aprire

oppure

Premi → Chiudere

Tenere premuto il pulsante **OK** per aprire/chiedere la porta.

Per scorrere le voci del menù premere i pulsanti  

Sul menù in modalità manuale vedrete le seguenti voci:

Premi → Aprire

Livello batteria

Batteria: 100%

Modalità (Mode) in uso

1. Mod: Manuale

Questa opzione vi permette di resettare le impostazioni e riportarle a quelle iniziali.

5. Ripr. Fabb.

Modalità Tempo



La Smart Autodoor di Eglu utilizza un orario di 24 ore per evitare qualsiasi ambiguità. L'ora viene reimpostata quando le batterie vengono rimosse o si verifica un'interruzione di corrente durante il funzionamento a rete. Se la porta non è connessa al Wi-Fi, passa automaticamente alla modalità luce. La modalità e l'ora devono quindi essere reimpostate manualmente.

Impostare la Modalità

1. Premere brevemente il pulsante per scorrere le varie opzioni fino a raggiungere la modalità (Mode)

1. Mod: Manuale

2. Tenere premuto il pulsante la modalità in uso inizierà a lampeggiare.

1. Mod: Manuale

3. Usare i pulsanti per scorrere le varie modalità

1. Mod: Manuale

1. Mod: Tempo

4. Tenere premuto per selezionare e confermare la nuova modalità

--Salvato--

Regolare l'orario attuale

1. Premere brevemente il pulsante per selezionare le impostazioni

2. Orario: 14:23

2. Tenere premuto fino a quando il blocco dei minuti inizierà a lampeggiare

2. Orario: 14: 23

3. Premere o per impostare i minuti

2. Orario: 14: 05

4. Premere per confermare e spostarsi al blocco delle ore che inizieranno a lampeggiare

2. Orario: 14 :05

5. Premere o per impostare l'ora

2. Orario: 18 :05

6. Tenere premuto per confermare. Sullo schermo apparirà la conferma: -Salvato-

--Salvato--

Impostare l'orario di apertura

1. Premere brevemente il pulsante  per raggiungere il display a destra

3. Aperto @ 01:00

2. Tenere premuto  fino a quando il blocco dei minuti inizierà a lampeggiare

3. Aperto @ 01:-00-

3. Premere  o  per impostare i minuti

3. Aperto @ 01:-30-

4. Premere  per confermare e spostarsi al blocco delle ore che inizieranno a lampeggiare

3. Aperto @ -01:-30

5. Premere  o  per impostare l'ora

3. Aperto @ -08:-30

6. Tenere premuto  per confermare.

--Salvato--

Impostare l'orario di chiusura

1. Premere brevemente il pulsante  per raggiungere il display a destra

4. Chiuso @ 01:00

2. Tenere premuto  fino a quando il blocco dei minuti inizierà a lampeggiare

4. Chiuso @ 01:-00-

3. Premere  o  per impostare i minuti

4. Chiuso @ 01:-15-

4. Premere  per confermare e spostarsi al blocco delle ore che inizieranno a lampeggiare

4. Chiuso @ -01:-15

5. Premere  o  per impostare l'ora

4. Chiuso @ -19:-15

6. Tenere premuto  per confermare.

--Salvato--

100 Modalità Luce



Se il livello di luminosità dove si trova il pannello di controllo cambia frequentemente (ad esempio molti vicini) la funzione luminosità rischia di non funzionare come ci si aspetterebbe - passate alla modalità oraria

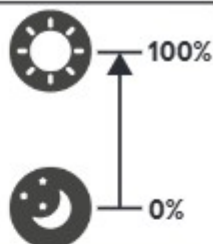

Impostare la Modalità

1. Premere brevemente il pulsante per scorrere le varie opzioni fino a raggiungere la modalità (Mode)

1. Mod: Manuale

2. Tenere premuto il pulsante la modalità in uso inizierà a lampeggiare.

1. Mod: Manuale

3. Usare i pulsanti per scorrere le varie modalità

1. Mod: Manuale

4. Tenere premuto per selezionare e confermare la nuova modalità

1. Mod: Luce

--Salvato--

Impostare il livello di luce per l'apertura



I livelli di luce dell'apertura della porta dovrebbero essere impostati con una percentuale più alta rispetto ai livelli di luce della chiusura porta. I due valori dovrebbero essere almeno del 10% distanziati l'uno dall'altro. Raccomandiamo di iniziare da 13 e 3 e poi aggiustare perché a seconda del posizionamento del pollaio, i livelli di luce possono risentirne. Potrebbero essere necessari degli aggiustamenti con i cambi di stagione.

1. Premere brevemente il pulsante per raggiungere il display a destra

3. Aperto @ 27

2. Tenere premuto fino a quando i numeri non inizieranno a lampeggiare

3. Aperto @ 27

3. Premere o per impostare il livello

3. Aperto @ 13

4. Premere per confermare.

--Salvato--

Impostare il livello di luce per la chiusura

1. Premere brevemente il pulsante  per raggiungere il display a destra

4. Chiuso @ 6

2. Tenere premuto  fino a quando i numeri non inizieranno a lampeggiare

4. Chiuso @  6

3. Premere  o  per impostare il livello

4. Chiuso @  3

4. Premere  per confermare.

--Salvato--

Impostare il ritardo di apertura



Automaticamente la porta automatica si apre o si chiude 20 minuti dopo che la luminosità selezionata è stata raggiunta. Potete aumentare lo scarto ma non potete scendere sotto i 20 minuti. E' stato pensato per evitare aperture o chiusure accidentali in caso il livello di luminosità cambiasse per poco tempo come ad esempio una macchina che passa con i fari accesi

1. Premere brevemente il pulsante  per raggiungere il display a destra

5. Apert. Rit. 0m

2. Tenere premuto  fino a quando i numeri non inizieranno a lampeggiare

5. Apert. Rit.  0m

3. Premere  o  per impostare i minuti

5. Apert. Rit.  7m

4. Premere  per confermare.

--Salvato--

Impostare il ritardo di chiusura



Stesso principio per ritardo di apertura - Vedi sopra.

1. Premere brevemente il pulsante  per raggiungere il display a destra

6. Chius. Rit. 0m

2. Tenere premuto  fino a quando i numeri non inizieranno a lampeggiare

6. Chius. Rit.  0m

3. Premere  o  per impostare i minuti

6. Chius. Rit.  10m

4. Premere  per confermare.

--Salvato--

95 Calibración

Cuando conecte su puerta automática inteligente giratoria Eglu por primera vez necesitará detectar la posición de la puerta. Pulse y mantenga pulsado el botón **OK**

La puerta automática inteligente giratoria Eglu se calibra automáticamente moviéndose una vez en cada dirección. Asegúrese de que la puerta automática no está bloqueada durante la calibración.

Durante la calibración, el panel de control indicará:

Calibrating...

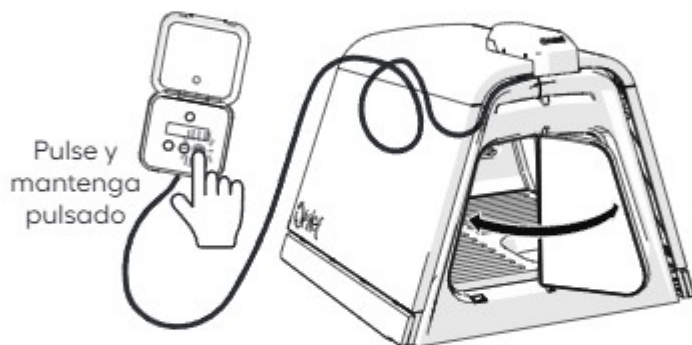

96 Cambiar idioma

1. Pulse el botón **↓** para desplazarse por el menú hasta llegar a esta pantalla:

Idioma: En

2. Pulse y mantenga pulsado **OK** para activar el cambio de idioma. El idioma actual parpadeará

Idioma: **En**

3. Utilice **↑** o **↓** para desplazarse por los idiomas hasta llegar al idioma deseado

Idioma: **Es**

4. Pulse y mantenga pulsado **OK** para confirmar la actualización del idioma

--Guardado--

Selección del modo de su puerta automática inteligente giratoria Eglu?

La puerta automática inteligente giratoria Eglu tiene 3 modos:

- **MANUAL:** La puerta se abrirá y cerrará si mantiene pulsado el botón **OK**.



- **TEMPORIZADOR:** Puede configurar la puerta automática inteligente giratoria Eglu para que se abra y cierre a horas específicas del día. La puerta se abrirá manualmente si mantiene pulsado el botón **OK**.



- **SENSOR DE LUZ:** Este es el modo predeterminado. La puerta automática inteligente giratoria Eglu se abrirá mediante el sensor de luz. La puerta se abrirá manualmente si mantiene pulsado el botón **OK**.

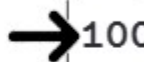

98 Modo manual

Pulse cualquiera de los tres botones **↑** **↓** **OK** y en la pantalla aparecerá:

Man. pul. para abrir

o

Man. pul. para cerrar

Mantenga pulsado el botón **OK** para abrir o cerrar la puerta.

Para avanzar por el menú, pulse para desplazarse hacia arriba y hacia abajo **↑** **↓** por los elementos del menú.

En el menú del modo manual verá lo siguiente:

Man. pul. para cerrar

Esto muestra el nivel de carga de la batería.

Batería: 100%

Esto muestra la configuración actual del modo.

1. Modo: Manual

Esto le da la opción de restablecer la configuración predeterminada del paquete de control tras cualquier cambio que realice.

5. Rest. de fábrica

99 Modo reloj



La puerta automática inteligente giratoria Eglu utiliza el reloj de 24 horas para evitar cualquier confusión. La hora se reiniciará cuando se extraigan las pilas. Asegúrese de actualizar la hora actual después de cada cambio de pilas.

Ajustar el modo

1. Pulse brevemente para desplazarse por las opciones hasta llegar al modo
2. Pulse y mantenga pulsado para poder cambiar el valor. El modo actual parpadeará
3. Utilice para desplazarse por los distintos modos
4. Pulse y mantenga pulsado para confirmar el cambio de valor

1. Modo: Manual

1. Modo: Manual

1. Modo: Manual

1. Modo: Reloj

--Guardado--

Ajuste de la hora actual

1. Pulse brevemente para desplazarse por las opciones hasta llegar a la opción modo del menú
2. Pulse y mantenga pulsado hasta que los minutos empiecen a parpadear
3. Pulse o para establecer los minutos
4. Pulse para pasar a cambiar las horas, que parpadearán para confirmar que están seleccionadas.
5. Pulse o para establecer las horas
6. Pulse y mantenga pulsado para confirmar. En la pantalla aparecerá -guardado-

2. Hora: 14:23

2. Hora: 14:23

2. Hora: 14:05

2. Hora: 14:05

2. Hora: 18:05

--Guardado--

Establecer la hora de apertura

1. Pulse brevemente  para desplazarse por las opciones hasta llegar a la pantalla de la derecha

3. Abrir @ 01:00

2. Pulse y mantenga pulsado  hasta que los minutos empiecen a parpadear

3. Abrir @ 01:

3. Pulse  o  para establecer los minutos

3. Abrir @ 01:

4. Pulse  para pasar a cambiar las horas, que parpadearán para confirmar que están seleccionadas

3. Abrir @ :30

5. Pulse  o  para establecer las horas

3. Abrir @ :30

6. Pulse y mantenga pulsado  para confirmar

--Guardado--

Establecer la hora de cierre

1. Pulse brevemente  para desplazarse por las opciones hasta llegar a la pantalla de la derecha

4. Cerrar @ 01:00

2. Pulse y mantenga pulsado  hasta que los minutos empiecen a parpadear

4. Cerrar @ 01:

3. Pulse  o  para establecer los minutos

4. Cerrar @ 01:

4. Pulse  para pasar a cambiar las horas, que parpadearán para confirmar que están seleccionadas

4. Cerrar @ :15

5. Pulse  o  para establecer las horas

4. Cerrar @ :15

6. Pulse y mantenga pulsado  para confirmar

--Guardado--

100 Modo luz



Si el nivel de luz en el lugar donde se encuentra el panel de control cambia con frecuencia (por ejemplo, en un barrio muy concurrido), es posible que el modo de luz no funcione como debería.

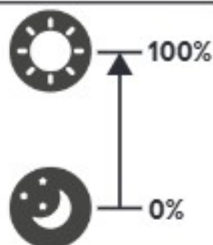

Ajustar el modo

1. Press for a short time to scroll through the options until you reach the mode
2. Press & Hold to enable changing the value. The current mode will flash
3. Utilice para desplazarse a través de los modos
4. Pulse y mantenga pulsado para confirmar el cambio de valor

1. Modo: Manual

1. Modo: Manual

1. Modo: Manual

1. Modo: Luz

--Guardado--

Ajuste del nivel de luz de apertura de la



El nivel de luz de apertura de la puerta debe ajustarse a un porcentaje mayor que el nivel de luz de cierre de la puerta. Los dos valores deben tener al menos un 10% de diferencia. Recomendamos empezar con 13 y 3, y luego ajustar según convenga, ya que la ubicación del gallinero puede afectar a los niveles de luz. Puede ser necesario realizar ajustes con el cambio de estación.

1. Pulse brevemente para desplazarse por las opciones hasta llegar a la pantalla de la derecha
2. Pulse y mantenga pulsado hasta que los números empiecen a parpadear
3. Pulse o para ajustar el nivel
4. Pulse y mantenga pulsado para confirmar

3. Abrir @ 27

3. Abrir @ 27

3. Abrir @ 13

--Guardado--

Ajuste del nivel de luz de cierre de la puerta

1. Pulse brevemente  para desplazarse por las opciones hasta llegar a la pantalla de la derecha

4. Cerrar @ 6

2. Pulse y mantenga pulsado  hasta que los números empiecen a parpadear

4. Cerrar @  6

3. Pulse  o  para ajustar el nivel

4. Cerrar @  3

4. Pulse y mantenga pulsado  para confirmar

--Guardado---

Ajuste del retardo de apertura



La puerta automática tiene un retardo predeterminado de fábrica establecido en 20 minutos después de que la luz alcanza el nivel requerido. No se puede bajar de 20 minutos y solo se pueden establecer minutos de retardo adicionales manualmente. Esto es para evitar cualquier apertura o cierre accidental de la puerta cuando el nivel de luz cambia por períodos cortos de tiempo, por ejemplo, si pasa un automóvil con las luces encendidas.

1. Pulse brevemente  para desplazarse por las opciones hasta llegar a la pantalla de la derecha

5.Ret. Apert. 0m

2. Pulse y mantenga pulsado  hasta que los números empiecen a parpadear

5.Ret. Apert.  0m

3. Pulse  o  para establecer los minutos

5.Ret. Apert.  7m

4. Pulse y mantenga pulsado  para confirmar

--Guardado---

Ajuste del retardo de cierre



El mismo principio que en el retardo de apertura (ver arriba).

1. Pulse brevemente  para desplazarse por las opciones hasta llegar a la pantalla de la derecha

6.Ret. Cierre. 0m

2. Pulse y mantenga pulsado  hasta que los números empiecen a parpadear

6.Ret. Cierre.  0m

3. Pulse  o  para establecer los minutos

6.Ret. Cierre.  10m

4. Pulse y mantenga pulsado  para confirmar

--Guardado---

95 Kalibrering

När du kopplar in din smarta roterande Eglu Autodörr för första gången måste den känna av dörrpositionen. Tryck och håll ner **OK** knappen.

Den smarta roterande Eglu Autodörren kommer automatiskt att kalibrera sig själv genom att flytta dörren en gång i varje riktning. Se till att den smarta roterande Eglu Autodörren inte är blockerad under kalibreringen.

Under kalibreringen kommer kontrollpanelen att visa:

Calibrating...

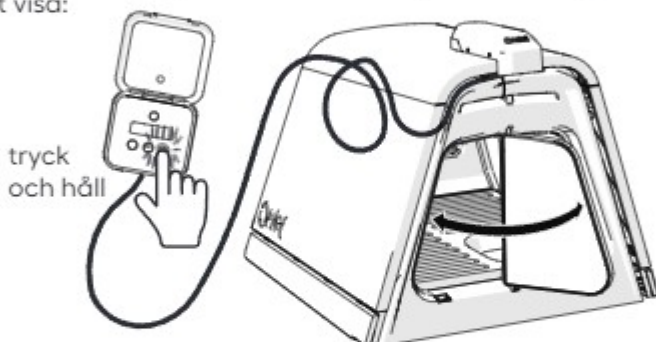

96 Ändra språk

1. Tryck på **↓** för att gå igenom menyn tills du kommer till den här skärmen:

Language: En

2. Tryck på och håll in **OK** för att ändra språket. Det nuvarande språkvalet kommer att blinka

Language: **En**

3. Använd **↑** eller **↓** för att bläddra bland språken tills du hittar det språk du vill använda

Språk: **SE**

4. Tryck på och håll in **OK** för att bekräfta ditt språkval

--Sparat--

97 Välj läge för din smarta roterande Eglu Autodörr?

Smart Rotary Eglu AutoDoor har 3 lägen:

• MANUELL - Dörren öppnas och stängs om du trycker och håller ner  knappen.

→ 98

• TID - Du kan ställa in Smart Rotary Eglu AutoDoor så att den öppnas och stängs vid specifika tider på dagen. Om du trycker och håller ner  knappen öppnas dörren manuellt.

→ 99

• LJUS - Detta är standardläget. Smart Rotary Eglu AutoDoor öppnas med hjälp av ljussensorn. Om du trycker och håller ner  knappen öppnas dörren manuellt.

→ 100

98 Manuell inställning



Tryck på någon av knapparna    så kommer skärmen visa:

Håll in → Öppna

eller

Håll in → Stänga

Håll ner  för att antingen öppna eller stänga dörren.

För att gå igenom menyn, tryck   för att gå igenom de olika menyvalen.

I den manuella inställningen kommer du se följande:

Håll in → Öppna

Här visas batterinivån

Batteri: 100%

Här visas den nuvarande inställningen.

1. Läge: Manuell

Ger dig möjlighet att återställa till fabriksinställningarna efter att du har gjort ändringar

5. Factory Reset



Den automatiska dörren använder en 24-timmarsklocka för att undvika tvetydighet. Tiden återställs när batterierna tas bort eller ett strömavbrott inträffar under nätdrift. Om dörren inte är ansluten till Wi-Fi växlar den automatiskt till ljusläge. Läge och tid måste då återställas manuellt.

Ställa in

1. Tryck och håll ner en  kort stund och skrolla tills du kommer till rätt inställning

1. Läge: Manuell

2. Håll ner  för att kunna ändra inställningarna. Det nuvarande värdet kommer blinka

1. Läge: ~~Manuell~~

3. Använd   för att välja

1. Läge: ~~Manuell~~1. Läge: ~~Tid~~

4. Håll ner  för att bekräfta ändringar

--Sparat--

Att ställa in klockan

1. Tryck på  för att komma åt menyn

2. Tid: 14:23

2. Håll ner  tills minuterna börjar blinka

2. Tid: 14:~~23~~

3. Tryck på  eller  för att ställa in rätt minut

2. Tid: 14:~~05~~

4. Tryck på  för att ändra till timmar, de kommer blinka för att bekräfta ändringen

2. Tid:~~14~~:05

5. Tryck på  eller  för att ställa in rätt timme

2. Tid:~~18~~:05

6. Håll ner  för att bekräfta. Skärmen kommer visa --Sparat--

--Sparat--

Ställ in öppningstidpunkt

1. Tryck på  för att komma åt menyn till höger

3. Öppna @ 01:00

2. Håll ner  tills minuterna börjar blinka

3. Öppna @ 01:00 

3. Tryck på  eller  för att ställa in rätt minut

3. Öppna @ 01:30 

4. Tryck på  för att ändra till timmar, de kommer blinka för att bekräfta ändringen

3. Öppna @ 01:30 

5. Tryck på  eller  för att ställa in rätt timme

3. Öppna @ 08:30 

6. Håll ner  för att bekräfta.

--Sparat--

Ställ in stängningstidpunkt

1. Tryck på  för att komma åt menyn till höger

4. Stäng @ 01:00

2. Håll ner  tills minuterna börjar blinka

4. Stäng @ 01:00 

3. Tryck på  eller  för att ställa in rätt minut

4. Stäng @ 01:15 

4. Tryck på  för att ändra till timmar, de kommer blinka för att bekräfta ändringen

4. Stäng @ 01:15 

5. Tryck på  eller  för att ställa in rätt timme

4. Stäng @ 19:15 

6. Håll ner  för att bekräfta.

--Sparat--



Om ljusnivån där kontrollpanelen sitter ofta ändras (om du till exempel bor någonstans där många bilar kör förbi) kan ljuställningen ibland inte fungera och du måste istället använda tidsinställningen

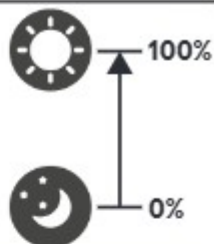

Ställa in

1. Tryck  på och skrolla tills du kommer till rätt inställning

2. Håll ner  för att kunna ändra inställningarna. Det nuvarande värdet kommer blinka

3. Använd   för att välja

4. Håll ner  för att bekräfta ändringar

1. Läge: Manuell

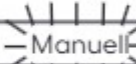
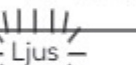
1. Läge:  Manuell1. Läge:  Manuell1. Läge:  Ljus

--Sparat--

Ställ in ljusnivå för öppning



Ljusnivån för öppning ska vara inställd på ett högre procenttal än den för stängning. De två värdena bör skilja åtminstone 10%. Vi rekommenderar att börja på 13 och 3, och sedan anpassa, eftersom hönhusets placering på kan påverka ljusnivåer. Du kan också behöva anpassa nivåerna efter årstiderna

1. Tryck på  för att komma åt menyn till höger

2. Håll ner  till siffrorna börjar blinka

3. Använd  och  för att välja rätt nivå

4. Håll ner  för att bekräfta.

3. Öppna @ 27

3. Öppna @  273. Öppna @  13

--Sparat--

1. Tryck på  för att komma åt menyn till höger

4. Stäng @ 6

2. Håll ner  till siffrorna börjar blinka

4. Stäng @ 6 

3. Använd  och  för att välja rätt nivå

4. Stäng @ 3 

4. Håll ner  för att bekräfta.

--Sparat--

Ställ in öppningsfördröjning



Som standard har autodörren en fördröjning på 20 minuter efter att ljuset nått den valda nivån. Du kan inte gå under 20 minuter men kan manuellt lägga till ytterligare minuter. Detta är för att motverka att dörren öppnas eller stängs av misstag när ljussensorn antingen är blockerad eller något lyser på den under kortare perioder, som när en bil kör förbi med helljuset på.

1. Tryck på  för att komma åt menyn till höger

5. Öppnings-Fördröjning 0m

2. Håll ner  till siffrorna börjar blinka

5. Öppnings-Fördröjning 0m 

3. Tryck på  eller  för att ställa in rätt minut

5. Öppnings-Fördröjning 7m 

4. Håll ner  för att bekräfta ändringar.

--Sparat--

Ställ in stängningsfördröjning



Samma princip som vid öppningsfördröjning - Se ovan.

1. Tryck på  för att komma åt menyn till höger

6. Stängnings-Fördröjning 0m

2. Håll ner  till siffrorna börjar blinka

6. Stängnings-Fördröjning 0m 

3. Tryck på  eller  för att ställa in rätt minut

6. Stängnings-Fördröjning 10m 

4. Håll ner  för att bekräfta ändringar.

--Sparat--

95 Kalibrering

Når du tilslutter din smarte, roterende Eglu AutoDoor for første gang, skal den registrere dørens position. Tryk **OK** og hold knappen nede.

Omløts smarte, roterende Eglu AutoDoor vil automatisk kalibrere sig selv ved at flytte døren én gang i hver retning. Sørg for, at den smarte, roterende Eglu AutoDoor ikke er blokeret under kalibrering.

Under kalibrering vil kontrolpanelet vise:

Calibrating...

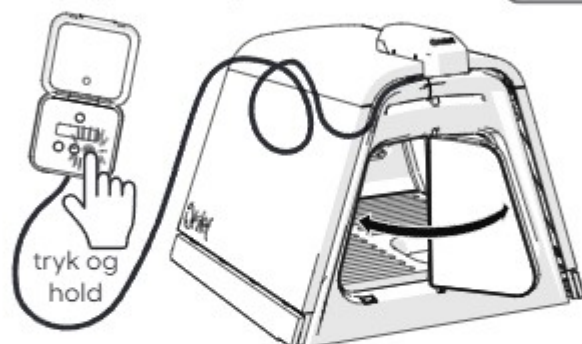

96 Skift sprog

1. Tryk på **↓** knappen for at bevæge dig igennem menuen indtil du når denne skærm:

Language: En

2. Tryk på **OK** og hold nede for at ændre sprog. Det nuværende sprogvvalg vil blinke

Language: **- En -**

3. Brug **↑** eller **↓** til at bevæge dig igennem sprogene indtil du kommer til dit ønskede sprog

Sprog: **- Dk -**

4. Tryk på **OK** og hold nede for at bekræfte dit sprogvvalg

--Gemt--

Den smarte roterende Eglu AutoDoor har 3 tilstande::

• MANUEL - Døren åbner og lukker, hvis du trykker på **OK** knappen og holder den nede.

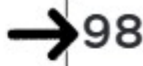



• TID - Du kan indstille den smarte roterende Eglu AutoDoor til at åbne og lukke på bestemte tidspunkter af døgnet. Hvis du trykker på **OK** knappen og holder den nede, åbnes døren manuelt.

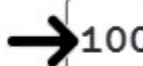

• LYS - Dette er standardtilstanden. Den smarte roterende Eglu AutoDoor åbner ved hjælp af lyssensoren. Hvis du trykker på **OK** knappen og holder den nede, åbnes døren manuelt.



98 Manuel funktion



Tryk på en af de tre knapper    og displayet vil vise:

Hold nede → åbn

eller

Hold nede → luk

Hold  knappen nede for at åbne eller lukke døren.

Du kan gennemgå hele menuen ved at trykke   for at gå op og ned gennem menupunkterne.

I menuen for manuel funktion ser du følgende:

Hold nede → åbn

Her vises batteriernes opladningsniveau.

Batteri: 100%

Her vises den aktuelle funktionsindstilling.

1. Funktion: Manuel

Her har du mulighed for at gendanne kontrolpanelets fabriksindstillinger efter eventuelle ændringer.

5. Gendan fabriksindstilling

99 Tidsindstillet funktion

Den automatiske dør bruger et 24-timers ur for at undgå tvetydighed.



Tiden nulstilles, når batterierne fjernes, eller der opstår strømafbrydelse under netdrift. Hvis døren ikke er forbundet til Wi-Fi, skifter den automatisk til lystilstand. Tilstand og tid skal derefter nulstilles manuelt.



Valg af funktion

1. Tryk og slip  for at navigere igennem mulighederne indtil du når til funktionen

1. Funktion: Manuel

2. Tryk  og hold knappen nede for at skifte funktion. Den aktuelle funktion blinker

1. Funktion: ~~Manuel~~

3. Brug   for at gå igennem de forskellige funktioner

1. Funktion: ~~Manuel~~

1. Funktion: ~~Tid~~

4. Tryk  og hold nede for at bekræfte dit valg

--Gemt--

Indstilling af klokkeslæt

1. Tryk og slip  for at nå punktet i funktionsmenuen

2. Tid nu: 14:23

2. Tryk  og hold nede indtil minutterne begynder at blinke

2. Tid Nu: 14: ~~23~~

3. Tryk  eller  for at indstille minutterne

2. Tid Nu: 14: ~~05~~

4. Tryk  for at skifte til timer, timerne blinker når de er valgt

2. Tid Nu: ~~14~~ :05

5. Tryk  eller  for at indstille timerne

2. Tid Nu: ~~18~~ :05

6. Tryk  og hold nede for at bekræfte. Displayet viser -Gemt-

--Gemt--

Indstilling af åbningstidspunkt

1. Tryk og slip  for at finde displayet til højre

3. Åbn @ 01:00

2. Tryk  og hold nede indtil minutterne begynder at blinke

3. Åbn @ 01:00

3. Tryk  eller  for at indstille minutterne

3. Åbn @ 01:30

4. Tryk  for at skifte til timer, timerne blinker når de er valgt

3. Åbn @ 01:30

5. Tryk  eller  for at indstille timerne

3. Åbn @ 08:30

6. Tryk  og hold nede for at bekræfte.

--Gemt--

Indstilling af lukketidspunkt

1. Tryk og slip  for at finde displayet til højre

4. Luk @ 01:00

2. Tryk  og hold nede indtil minutterne begynder at blinke

4. Luk @ 01:00

3. Tryk  eller  for at indstille minutterne

4. Luk @ 01:15

4. Tryk  for at skifte til timer, timerne blinker når de er valgt

4. Luk @ 01:15

5. Tryk  eller  for at indstille timerne

4. Luk @ 19:15

6. Tryk  og hold nede for at bekræfte.

--Gemt--





100 Lyssensor funktion

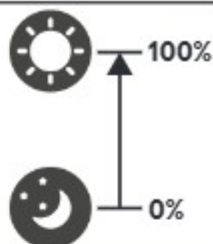

Hvis lysniveauet ændrer sig ofte, der hvor kontrolpanelet er placeret (f.eks. i et travlt nabolag), vil lysfunktionen muligvis ikke fungere efter hensigten - anvend i så fald tidsfunktionen i stedet



Valg af funktion

1. Tryk og slip  for at navigere igennem mulighederne indtil du når til funktionen
2. Tryk  og hold knappen nede for at skifte funktion. Den aktuelle funktion blinker
3. Brug   for at gå igennem de forskellige funktioner
4. Tryk  og hold nede for at bekræfte dit valg.

1. Funktion: Manuel

1. Funktion:  Manuel

1. Funktion:  Manuel

1. Funktion:  Lys

--Gemt--

Indstilling af lysniveau ved åbning



Lysniveauet for åbning af døren skal sættes til en højere procentdel end lysniveau ved lukning. Der skal være mindst 10% forskel mellem de to værdier. Vi anbefaler, at du starter med værdierne 13 og 3, og justerer derudfra efter behov, da hønsehusets placering kan påvirke mængden af lys. Justeringer kan også være nødvendige når årstiderne skifter

1. Tryk og slip  for at finde displayet til højre
2. Tryk  og hold nede indtil tallene begynder at blinke
3. Tryk  eller  for at indstille niveauet
4. Tryk  og hold nede for at bekræfte.

3. Åbn @ 27

3. Åbn @  27

3. Åbn @  13

--Gemt--

Indstilling af lysniveau ved lukning

1. Tryk og slip  for at finde displayet til højre

4. Luk @ 6

2. Tryk  og hold nede indtil tallene begynder at blinke

4. Luk @ 6

3. Tryk  eller  for at indstille niveauet

4. Luk @ 3

4. Tryk  og hold nede for at bekræfte.

--Gemt--

Indstilling af forsinkelse af åbningstidspunktet





I fabriksindstillingerne er den automatiske dør indstillet med 20 minutters forsinkelse, eller delay, efter at lyset rammer det valgte niveau. Delay kan ikke være under 20 minutter og kan kun manuelt indstilles ved at lægge yderligere tid til. Dette er for at forhindre utilsigtet åbning eller lukning af døren, når lyset ændrer sig i kortere perioder, f.eks. hvis en bil kører forbi og lyset fra forlygterne rammer sensoren.

1. Tryk og slip  for at finde displayet til højre

5. Åbn-Delay 0m

2. Tryk  og hold nede indtil tallene begynder at blinke

5. Åbn-Delay 0m

3. Tryk  eller  for at indstille minutterne

5. Åbn-Delay 7m

4. Tryk  og hold nede for at bekræfte.

--Gemt--

Indstilling af forsinkelse af lukketidspunktet



Samme princip som ved åbningsforsinkelse - Se ovenfor.

1. Tryk og slip  for at finde displayet til højre

6. Luk-Delay 0m

2. Tryk  og hold nede indtil tallene begynder at blinke

6. Luk-Delay 0m

3. Tryk  eller  for at indstille minutterne

6. Luk-Delay 10m

4. Tryk  og hold nede for at bekræfte.

--Gemt--

101 Emergency Fail Safe/Troubleshooting

DE Sicherheit im Notfall/Fehlerbehebung

FR Sécurité d'urgence/Dépannage

NL Veiligheid bij noodgevallen/probleemoplossing

IT Sistema di sicurezza/Risoluzione dei problemi

ES A prueba de fallos de emergencia/Solución de problemas

SE Säker i nödsituationer/Felsökning

DK Sikker i nødsituationer / Fejlfinding



In the event that:

- 1) the motor fails,
- 2) the batteries go flat,
- 3) or there is any other blockage, you can move the door manually by removing the gear case (106.0005) and using the T-Handle, as well as trying out the following trouble shooting tips.

- **DE** Für den Fall dass: 1) der Motor versagt, 2) die Batterien leer sind, 3) oder es liegt eine andere Blockade vor Sie können die Tür manuell bewegen, indem Sie das Getriebegehäuse (106.0005) entfernen und den T-Griff verwenden sowie Folgendes ausprobieren.

- **FR** Si l'un des problèmes suivants se présente : 1) le moteur tombe en panne, 2) les piles sont déchargées, 3) ou s'il y a un autre blocage vous pouvez déplacer la porte manuellement en retirant le boîtier d'engrenage (106.0005) et en utilisant la poignée en T, ainsi qu'en essayant les solutions suivantes.

- **NL** In het geval dat: 1) de motor faalt, 2) de batterijen leeg zijn, 3) of er is een andere blokkade u kunt de deur handmatig verplaatsen door de Gear Case (106.0005) te verwijderen en de T-hendel te gebruiken, en door het volgende uit te proberen.

- **IT** In caso di emergenza quale: 1. rottura del motore, 2. batteria scarica, 3. o c'è un altro blocco puoi spostare la porta manualmente rimuovendo la centralina (106.0005) e usando la maniglia a T, oltre a provare quanto segue.

- **ES** En el caso de que: 1) El motor falle, 2) Las pilas se agoten, 3) O haya cualquier otra obstrucción usted puede mover la puerta manualmente quitando la caja de engranajes (106.0005) y usando el tirador en T, así como probar lo siguiente.

- **SE** Ifall: 1) Motorn går sönder, 2) Batteriet dör, eller 3) eller det finns någon annan blockering du kan flytta dörren manuellt genom att ta bort Gear Case (106.0005) och använda T-handtaget, samt prova följande.

- **DK** I tilfælde af: 1) motorfejl, 2) flade batterier eller 3) eller der er en anden blokering du kan flytte døren manuelt ved at fjerne gearkassen (106.0005) og

102



Keep the Parts safe until Step 106



- **DE** Legen Sie die Teile bis Schritte 106 beiseite
- **FR** Mettez ces pièces de côté pour les étapes 106
- **NL** Leg de onderdelen opzij tot stap 106
- **IT** Mettere da parte fino ai Punti 106
- **ES** Guarde la pieza hasta el paso 106
- **SE** Lägg undan delarna till Steg 106
- **DK** Læg delene til side indtil trin 106

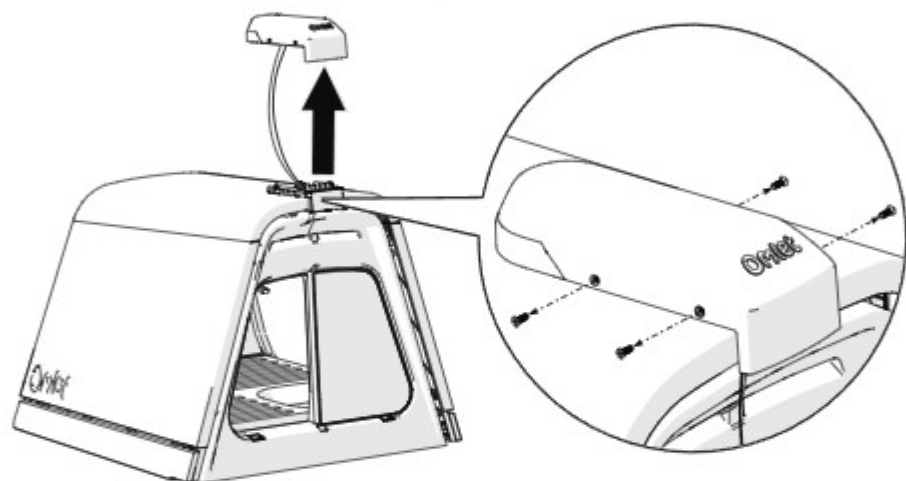

While troubleshooting keep the Gear Case (106.0005) close to T-Handle to keep the wires at the correct length. If necessary pull the wires tight again while replacing the Gear Case (106.0005) in Step 106.



· **DE** Halten Sie das Getriebegehäuse **(106.0005)** während der Fehlerbehebung nahe am T-Griff, um die Kabel auf der richtigen Länge zu halten. Falls erforderlich, ziehen Sie die Kabel wieder fest, wenn Sie das Getriebegehäuse **(106.0005)** in Schritt 106 austauschen.

· **FR** Pendant le dépannage, gardez le boîtier d'engrenages **(106.0005)** à proximité de la poignée en T pour maintenir les câbles à la bonne longueur. Si nécessaire, resserrez les câbles lors du remplacement du boîtier d'engrenages **(106.0005)** à l'étape 106.

· **NL** Houd de Gear Case **(106.0005)** bij probleemoplossing dicht bij de T-handgreep om de kabels op de juiste lengte te houden. Trek de kabels indien nodig opnieuw aan bij het vervangen van de Gear Case **(106.0005)** in stap 106.

· **IT** Durante la risoluzione dei problemi tenere la centralina **(106.0005)** vicino all'impugnatura a T per mantenere i cavi della lunghezza corretta. Se necessario, stringere nuovamente i cavi quando si sostituisce la centralina **(106.0005)** nel punto 106.

· **ES** Durante la detección de fallos, mantenga la caja de engranajes **(106.0005)** cerca del tirador en T para mantener los cables con la longitud correcta. Si es necesario, vuelva a tensar los cables mientras sustituye la caja de engranajes **(106.0005)** en el paso 106.

· **SE** För att felsöka, håll Gear Case **(106.0005)** nära T-handtaget så att kablarna har rätt längd. Dra vid behov åt kablarna igen samtidigt som du byter ut Gear Case **(106.0005)** i steg 106.

· **DK** Under fejlfinding skal gearkassen **(106.0005)** holdes tæt på T-håndtaget for at holde ledningerne i den korrekte længde. Om nødvendigt, træk ledningerne stramt igen, mens du udskifter gearkassen **(106.0005)** i trin 106.

103 Manually Moving the Door

DE Manuelle Bewegen der Tür • **FR** Manœuvre manuelle de la porte
NL De deur handmatig bedienen • **IT** Azionamento manuale della porta • **ES** Mover la puerta manualmente • **SE** Flytta dörren manuellt
DK Manuel flytning af døren

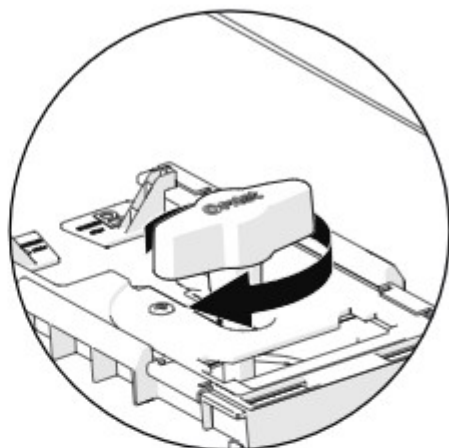
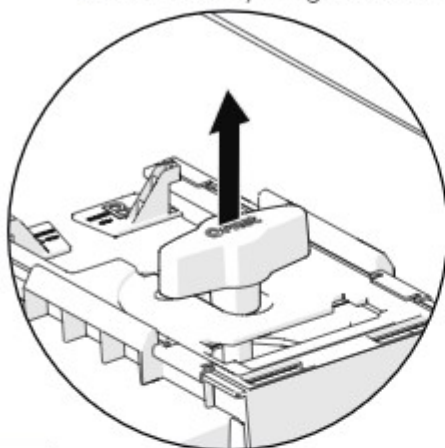

104 Troubleshooting the Door Switch (106.0017)

DE Fehlerbehebung beim Türschalter (106.0017)
FR Dépannage de l'interrupteur de porte (106.0017)
NL Probleemoplossing deurschakelaar (106.0017)
IT Risoluzione dei problemi relativi all'interruttore della porta (106.0017)
ES Solución de problemas del interruptor de la puerta (106.0017)
SE Felsökning av dörrbrytaren (106.0017)
DK Fejlfinding af dørkontakten (106.0017)

Make sure the wire is connected properly.



- **DE** Stellen Sie sicher, dass das Kabel richtig angeschlossen ist.
- **FR** Assurez-vous que le câble est correctement connecté.
- **NL** Assicurerse che il cavo sia collegato correttamente.
- **IT** Assicurerse che il cavo sia collegato correttamente.
- **ES** Asegúrese de que el cable está bien conectado.
- **SE** Se till att kabeln är ordentligt ansluten.
- **DK** Sørg for, at ledningen er tilsluttet korrekt.

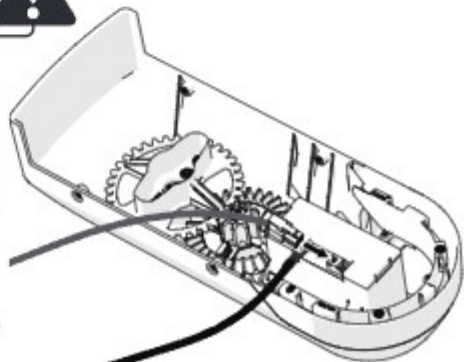

- DE** Zurücksetzen der intelligenten, drehbaren Eglu Autodoor
FR Réinitialisation de la Porte Automatique intelligente rotative Eglu
NL De Slimme, roterende Eglu Autodoor resetten
IT Ripristino della Smart Autodoor girevole Eglu
ES Reiniciar la puerta automática inteligente giratoria Eglu
SE Återställ den smarta Autodörr till Eglu-hönshus
DK Nulstilling af Omlets smarte, roterende Eglu AutoDoor

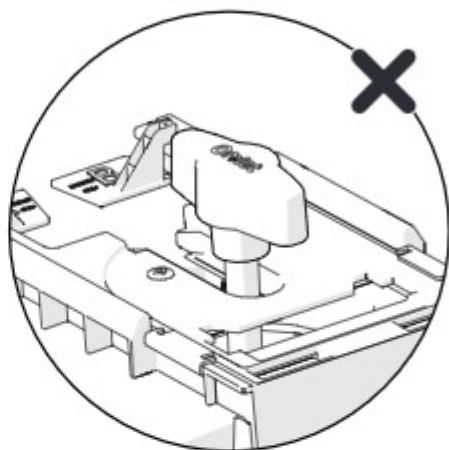
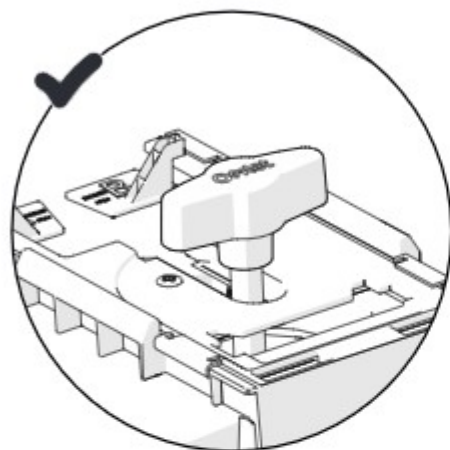

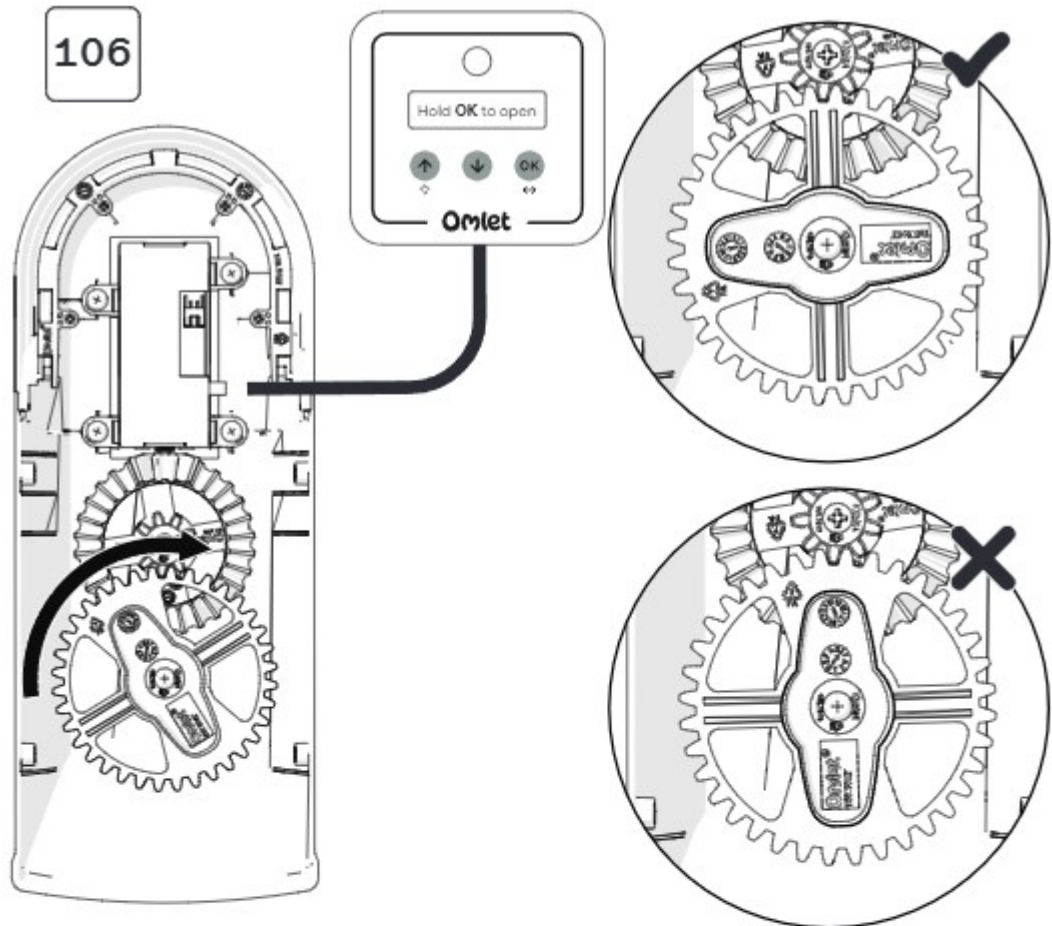

Hold the **OK** button until the motor spins. Press **OK** to stop the motor when it is in the correct position.

- **DE** Halten Sie OK gedrückt, bis sich der Motor dreht / Drücken Sie OK, um den Motor anzuhalten, wenn er sich in der richtigen Position befindet.
- **FR** Maintenez OK jusqu'à ce que le moteur tourne / Appuyez sur OK pour arrêter le moteur lorsqu'il est dans la bonne position.
- **NL** Houd OK ingedrukt tot de motor gaat draaien / Druk op OK om de motor te stoppen wanneer hij zich in de juiste positie bevindt.
- **IT** Tenere premuto OK fino a quando il motore non gira / Premere OK per arrestare il motore quando si trova nella posizione corretta.
- **ES** Mantenga pulsado OK hasta que el motor gire / Pulse OK para parar el motor cuando esté en la posición correcta.
- **SE** Håll in OK knappen tills motorn snurrar / Tryck på OK för att stoppa motorn när den är i rätt läge.
- **DK** Hold OK nede, indtil motoren drejer / Tryk OK for at stoppe motoren, når den er i den rigtige position.

107



Pull wires tight



- **DE** Ziehen Sie die Kabel fest an
- **FR** Tirez sur les câbles pour les serrer
- **NL** Trek de kabels strak aan
- **IT** Tirare i cavi per stringerli
- **ES** Tense los cables
- **SE** Dra åt kablarna
- **DK** Træk ledningerne stramt

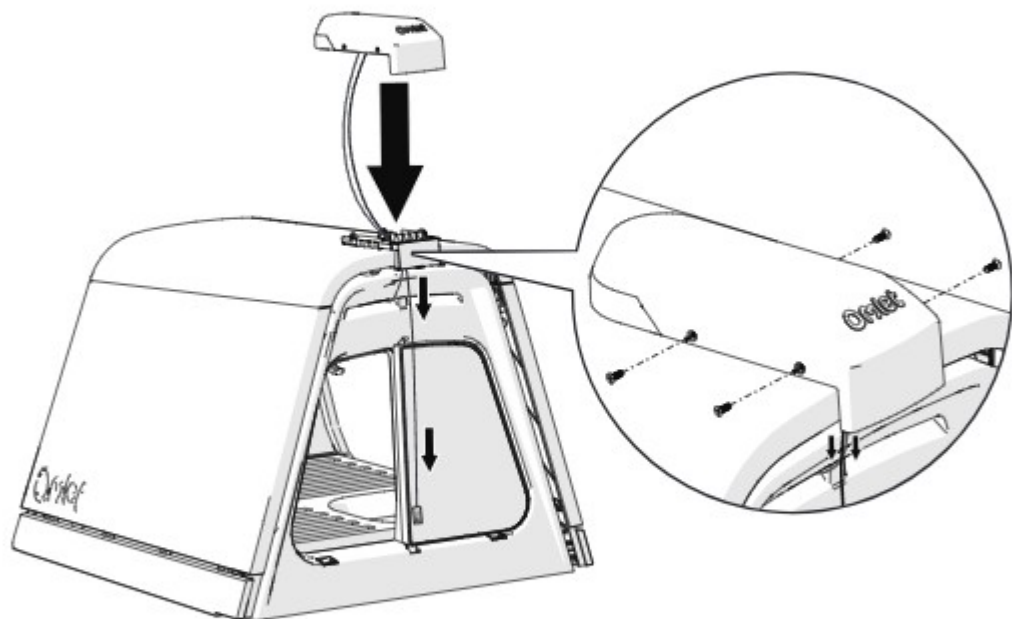

After rain in freezing temperatures, sleet or snow you may need to defrost your Autodoor to restore proper function to moving parts. To do this we recommend pouring warm (not boiling) water over any affected parts and then drying them.



- **DE** Nach Regen bei frostigen Temperaturen, Schneeregen oder Schnee müssen Sie Ihre Autodoor eventuell enteisen, um die Funktion der beweglichen Teile wiederherzustellen. Dazu empfehlen wir, die betroffenen Teile mit warmem (nicht kochendem) Wasser zu übergießen und anschließend zu trocknen.
- **FR** Après une pluie par temps de gel, ou lorsqu'il y a de la neige fondue ou de la neige, il peut être nécessaire de dégivrer votre Porte Automatique afin de rétablir le bon fonctionnement des pièces mobiles. Dans cette situation, nous vous recommandons de verser de l'eau chaude (non bouillante) sur toutes les pièces concernées, puis de les sécher.
- **NL** Na regen bij vriestemperaturen, ijzel of sneeuw kan het nodig zijn om uw Autodoor te ontdooien. Dit om een goede werking van bewegende delen te garanderen. We raden aan dit te doen door warm (niet kokend) water over de betreffende delen te gieten en deze daarna af te drogen.
- **IT** Dopo la pioggia se le temperature ghiacciano, grandine e neve potrebbero portarvi a sghiacciare la vostra Autodoor per ripristinare le corrette funzioni delle parti mobili. Per farlo, raccomandiamo di versare dell'acqua calda (non a ebollizione) sulle parti interessate e poi asciugarle.
- **ES** Después de que llueva con temperaturas bajo cero, aguanieve o nieve, puede que necesite descongelar su puerta automática para restaurar el correcto funcionamiento de las piezas móviles. Para ello, recomendamos verter agua caliente (no hirviendo) sobre las piezas afectadas y secarlas bien a continuación.
- **SE** Efter att det snöat eller regnat vid minusgrader kan du behöva frosta av din dörr för att se till att alla rörliga delar fungerar som de ska. Vi rekommenderar att hålla varmt (inte kokande) vatten över de delar som påverkats och sedan torka dem.
- **DK** Efter regn i temperaturer under frysepunktet, slud eller sne kan du være nødsaget til at afrime din automatiske dør til hønsehuset for at genoprette korrekt funktion for de bevægelige dele. For at gøre dette anbefaler vi, at du hælder varmt (ikke kogende) vand henover berørte dele og derefter tørrer dem af.

For more support go to: www.omlet.co.uk/support/



- **DE** Weitere Unterstützung finden Sie unter www.omlet.de/support/
- **FR** Pour des instructions plus détaillées, veuillez consulter la page <https://www.omlet.fr/support/>
- **IT** Per ricevere ulteriore assistenza, visitare <https://www.omlet.it/support/>
- **NL** Ga voor meer gedetailleerde instructies naar www.omlet.nl/support/
- **ES** Para obtener más ayuda, visite: <https://www.omlet.es/support/>
- **SE** Besök <https://www.omlet.se/support/> om du behöver mer support.
- **DK** For mere information og kundesupport gå til www.omlet.dk/support/



Recycling information:

DE Informationen zum Recycling:

FR Informations sur le recyclage :

NL Recyclinginformatie:

IT Informazioni sul riciclaggio:

ES Información de reciclaje:

SE Information om återvinning:

DK Oplysninger om genbrug:

This symbol on the product indicates that it must not be disposed of with household waste. Instead, it should be taken to an appropriate collection point for recycling of electrical and electronic equipment. This helps conserve natural resources and prevent potential negative effects on human health and the environment.



· **DE** Dieses Symbol auf dem Produkt weist darauf hin, dass es nicht mit dem Hausmüll entsorgt werden darf. Stattdessen sollte es zu einer geeigneten Sammelstelle für das Recycling von Elektro- und Elektronikgeräten gebracht werden. Dies trägt zur Schonung natürlicher Ressourcen bei und verhindert mögliche negative Auswirkungen auf die menschliche Gesundheit und die Umwelt.

· **FR** Ce symbole sur le produit indique qu'il ne doit pas être jeté avec les déchets ménagers. Il doit être apporté à un point de collecte approprié pour le recyclage des équipements électriques et électroniques. Cela contribue à préserver les ressources naturelles et à prévenir les effets potentiellement négatifs sur la santé humaine et l'environnement.

· **NL** Dit symbool op het product geeft aan dat het niet bij het huishoudelijk afval mag worden weggegooid. In plaats daarvan moet het naar een geschikt inzamelpunt voor recycling van elektrische en elektronische apparatuur worden gebracht.

Dit helpt natuurlijke hulpbronnen te behouden en mogelijke negatieve effecten op de menselijke gezondheid en het milieu te voorkomen.

· **IT** Questo simbolo sul prodotto indica che non deve essere smaltito insieme ai rifiuti domestici. Deve invece essere consegnato presso un punto di raccolta appropriato per il riciclaggio di apparecchiature elettriche ed elettroniche. Questo contribuisce a preservare le risorse naturali e a prevenire potenziali effetti negativi sulla salute umana e sull'ambiente.

· **ES** Este símbolo en el producto indica que debe no desecharse con la basura doméstica. Debe llevarse a un punto de recogida adecuado para el reciclaje de aparatos electrónicos. Esto ayuda a conservar los recursos naturales y prevenir posibles efectos negativos sobre la salud humana y el medio ambiente.

· **SE** Den här symbolen på produkten visar att den inte får slängas i de vanliga hushållssoporna. Istället ska den sopsorteras som elavfall och tas till en återvinningscentral eller en butik som tar emot elavfall för återvinning. Det här minskar miljöpåverkan eftersom materialet kan återanvändas.

· **DK** Dette symbol på produktet indikerer, at det ikke må smides ud sammen med husholdningsaffald. I stedet bør det bringes til et passende indsamlingssted til genbrug af elektrisk og elektronisk udstyr. Dette hjælper med at bevare naturlige ressourcer og forhindre potentielle negative effekter på menneskers sundhed og miljøet.

HERE'S WHERE IT STARTS

Omlet



Please reuse,
compost,
recycle.

© Copyright Omlet Ltd. 2026

Design registered, patent pending

Omlet and Eglu are registered trademarks of Hebe Studios Ltd.

820.2408_Instruction Manual Smart Rotary Eglu
Autodoor_ 13/02/2026



FR
Cet appareil,
ses accessoires
et cordons
se recyclent

À DÉPOSER
EN MAGASIN



À DÉPOSER
EN DÉCHÈTERIE



OU

Points de collecte sur www.quefairedesdechets.fr
Privilégiez la réparation ou le don de votre appareil!

