

ZIPPI RUN

Assembly guide



Omlet

EN Important Information. Please read before use

Check your clips regularly for signs of wear and tear. Weakened clips will affect the integrity of your run, as will misplaced clips. Give your product a little TLC over time. The coating on metal components may require some maintenance; we recommend rinsing occasionally with tap water, particularly if you live near the coast, where salt can accelerate corrosion. If you see rust spots, repair the area. Seek professional advice if you're not sure how to do so.

DE Wichtige Informationen. Vor Gebrauch bitte lesen

Überprüfen Sie die Clips regelmäßig auf Schäden und Verschleiß. Mangelhafte sowie falsch platzierte Clips beeinträchtigen die Integrität Ihres Geheges. Warten Sie Ihr Produkt regelmäßig. Die Beschichtung von Metallteilen erfordert möglicherweise eine gewisse Pflege; wir empfehlen, sie gelegentlich mit Leitungswasser abzuspülen, insbesondere wenn Sie in Küstennähe wohnen, wo Salz die Erosion beschleunigen kann. Sollten sich Rostflecken bilden, reparieren Sie die Stelle. Holen Sie sich professionellen Rat, wenn Sie sich nicht sicher sind, wie Sie dabei vorgehen sollen.

FR Information importante. À lire avant utilisation

Vérifiez régulièrement l'état de vos clips d'attache. Des clips usés ou mal positionnés peuvent compromettre la solidité de votre enclos. Prenez soin de votre produit dans le temps. Le revêtement des pièces métalliques peut nécessiter un entretien occasionnel : nous vous conseillons de les rincer à l'eau du robinet de temps à autre, surtout si vous vivez en bord de mer, car le sel accélère la corrosion. Si vous apercevez des taches de rouille, traitez la zone concernée. N'hésitez pas à demander l'avis d'un professionnel si vous ne savez pas comment procéder.

NL Belangrijke informatie. Lees a.u.b. aandachtig voor gebruik

Controleer je clips regelmatig op tekenen van slijtage. Verzwakte clips tasten de integriteit van je ren aan, net als verkeerd geplaatste clips. Geef je product na verloop van tijd een beetje liefde en aandacht. De coating op metalen onderdelen kan wat onderhoud nodig hebben; we raden aan om af en toe af te spoelen met kraanwater, vooral als je in de buurt van de kust woont, waar zout de erosie kan versnellen. Als je roestplekken ziet, herstel de plek dan. Vraag professioneel advies als je niet zeker weet hoe je dit moet doen.

IT Informazioni importanti. Leggere prima dell'utilizzo

Controllate regolarmente le condizioni delle clip. Clip usurate o mal posizionate possono compromettere l'integrità del recinto. Prendetevi cura del vostro prodotto nel tempo. Il rivestimento delle parti metalliche potrebbe richiedere della manutenzione; vi consigliamo di sciacquarle di tanto in tanto con acqua di rubinetto, soprattutto se vivete in zone costiere, in cui il sale può accelerare la corrosione. Se notate macchie di ruggine, trattate l'area interessata. Non esitate a rivolgervi a un professionista in caso di dubbi su come procedere.

ES Información importante. Lea antes de usar.

Revise sus clips con regularidad para detectar signos de desgaste. Los clips debilitados afectarán la integridad de su parque, al igual que los clips extraviados. Mantenga su parque en buen estado con el paso del tiempo. El revestimiento sobre el metal puede requerir algo de mantenimiento; recomendamos enjuagar ocasionalmente con agua del grifo especialmente si vives cerca de la costa, donde la sal puede acelerar la corrosión. Repare la zona si detecta manchas de óxido. Busque asesoramiento profesional si no está seguro de cómo hacerlo.

SE Viktig information. Läs innan du använder

Kontrollera dina klämmor regelbundet för tecken på slitage. Försvagade klämmor kommer att påverka din löprundas integritet, liksom felplacerade klämmor. Ge din produkt lite kärlek med tiden. Beläggningen på metallkomponenter kan kräva lite underhåll; vi rekommenderar att du sköljer då och då med kranvatten, särskilt om du bor nära kusten, där salt kan påskynda erosion. Om du ser rostfläckar, reparera området. Sök professionell rådgivning om du är osäker på hur du gör det.

DK Vigtig information. Læs venligst, før du bruger produktet

Tjek dine klemmer regelmæssigt for tegn på slitage. Svækkede klemmer vil påvirke integriteten af din løbegård, som forkerte placeringer. Giv dit produkt en kærlig hånd løbene. Overfladen på metallkomponenter kan kræve lidt vedligeholdelse; vi anbefaler at skylle med postevand lejlighedsvis, især hvis du bor nær kysten, hvor saltet kan fremskynde korrosion. Hvis du ser rustpletter, skal du reparere området. Søg professionel vejledning, hvis du er i tvivl om, hvordan du gør det.

Tip: Warm your clips in warm water to make them easier to use.

DE Tipp: In warmen Wasser werden die Clips ein wenig weicher und sind dann einfacher zu benutzen.

FR Astuce: réchauffez les clips dans de l'eau chaude pour faciliter leur mise en place.

NL Tip: het verwarmen van de clips in warm water vergroot het gebruiksgemak.

IT Consiglio: immergi le clip in acqua tiepida per ammorbidire temporaneamente la plastica.

ES Consejo: Caliente los clips en agua tibia para que sean más fáciles de usar.

SE Tips: Lägga klämmorna i varmt vatten så blir de lättare att använda.

DK Tip: Varm dine klip i varmt vand for at gøre dem nemmere at bruge.

How to attach Mighty Clips A (810.0135)



DE Wie man die Mighty Clips A (810.0135) befestigt

FR Comment attacher les Mighty Clips A (810.0135)

NL Mighty Clips A (810.0135) bevestigen

IT Come attaccare le Mighty Clips A (810.0135)

ES Cómo colocar los Mighty Clips A (810.0135)

SE Så här fäster du Mighty Clips A (810.0135)

DK Sådan bruges Mighty Clips A (810.0135)

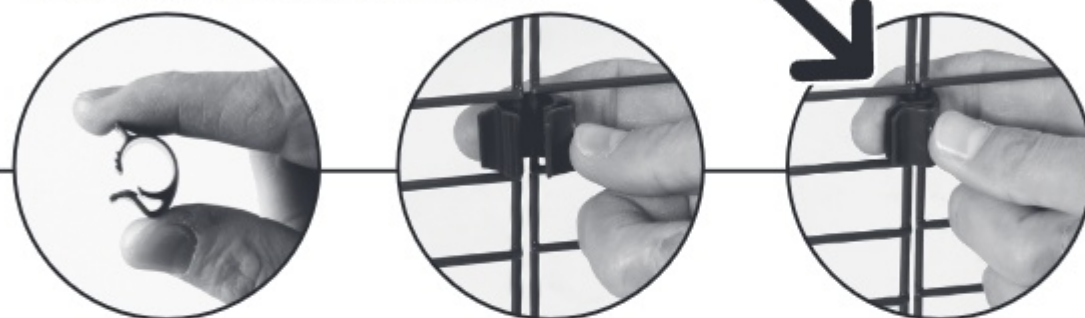

For more support go to: www.omlet.co.uk/support/

DE Weitere Unterstützung finden Sie unter www.omlet.de/support/

FR Pour des instructions plus détaillées, veuillez consulter la page www.omlet.fr/support/

NL Voor meer hulp, ga naar: www.omlet.nl/support/

IT Per ricevere ulteriore assistenza, visitare www.omlet.it/support/

ES Para más información o ayuda, visite: www.omlet.es/support/

SE Du hittar mer hjälp på: www.omlet.se/support/

DK For mere støtte, gå til: www.omlet.dk/support/



For a Zippi Run with roof, you will need...

DE Für einen Zippi Auslauf mit Dach benötigen Sie ... - **FR** Pour un enclos Zippi avec un toit, il vous faudra...

NL Voor een Zippi ren met dak heb je nodig... - **IT** Per un recinto Zippi con un tetto, avrete bisogno di...

ES Para un Zippi Run con techo, necesitará... - **SE** För en Zippi-gård med tak behöver du...

DK Til en Zippi løbegård med tag, skal du bruge...



Zippi Run Starter Pack options

DE Optionen für das Zippi Auslauf Starterpack • **FR** Configurations de base de l'enclos Zippi • **NL** Opties voor het Zippi ren startpakket • **IT** Kit base per recinto Zippi • **ES** Opciones del kit de inicio Zippi Run • **SE** Olika val för startpaket
DK Forskellige muligheder for Zippi løbegård med tag-startpakke

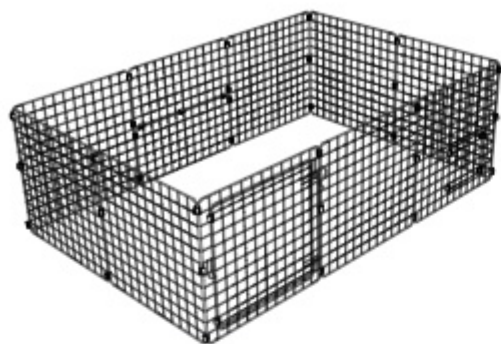

079.0001: Starter Pack Low

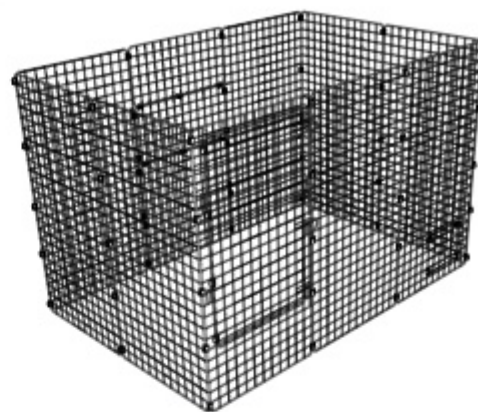

079.0002: Starter Pack High

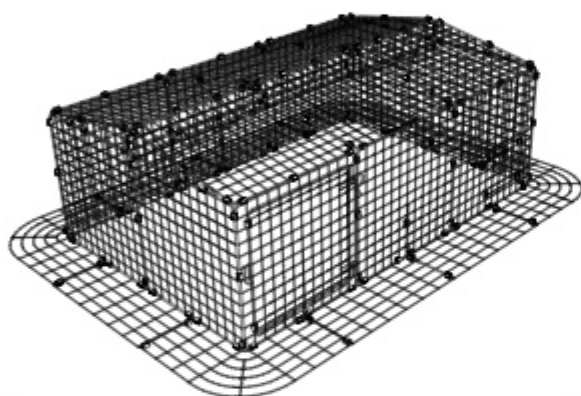

079.0001: Starter Pack Low

+ 079.0013: Roof Starter Pack

+ 079.0010: Skirt Starter Pack

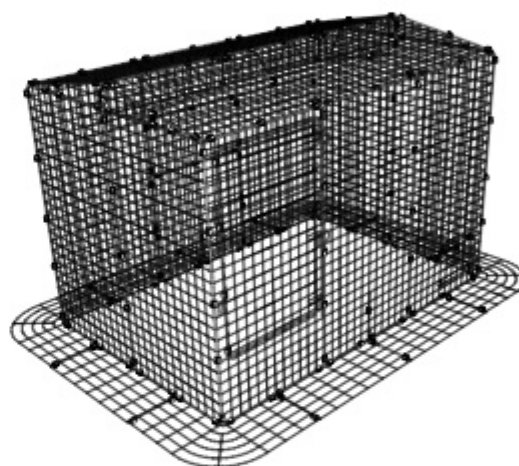

079.0002: Starter Pack High

+ 079.0013: Roof Starter Pack

+ 079.0010: Skirt Starter Pack



079.0001: Starter Pack Low

+ 079.0013: Roof Starter Pack

+ 079.0009: Underfloor Mesh Panel 6-Pack

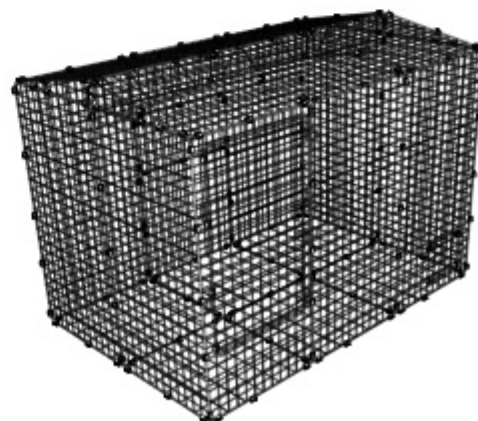

079.0002: Starter Pack High

+ 079.0013: Roof Starter Pack

+ 079.0009: Underfloor Mesh Panel 6-Pack

Starter Packs' Contents

DE Inhalte der Starterpacks • FR Contenu des packs de démarrage • NL Inhoud starterspakket • IT Contenuti degli starter pack • ES Contenidos de los packs de inicio • SE Innehåll i startpaketen • DK Begyndersæt indhold

079.0001: Starter Pack Low

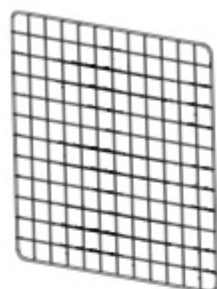

48x48 Panel
079.1000
x7

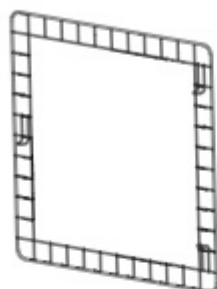

48x48 Panel Door
Frame
079.1002
x1

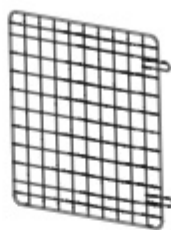

48x48 Panel
Door
079.1003
x1

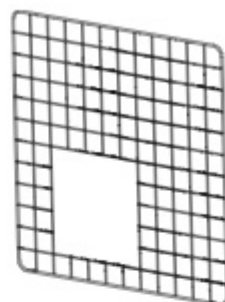

48x48 Tunnel Connection
Frame
079.1019
x1



Run Door Pin
810.0011
x1

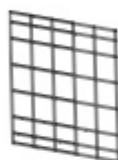

Tunnel
Connection Door
079.1020
x1

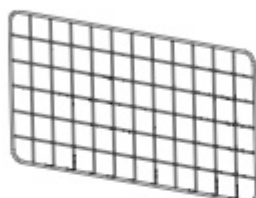

24x48 Panel
079.1006
x2

810.0424.041000: Bagged Run Clips



Run Clip
810.0135
x41

810.0138: Bagged Omlet Badge



Omlet Badge
810.0137
x2

079.0002: Starter Pack High

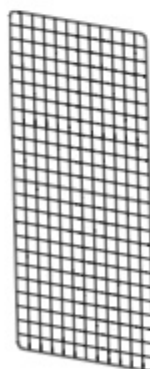

96x48 Panel
079.1001
x7

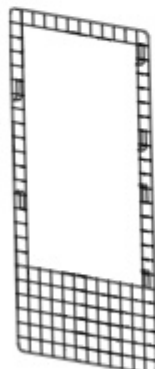

96x48 Panel Door
Frame
079.1004
x1

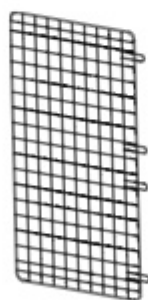

96x48 Panel Door
079.1005
x1

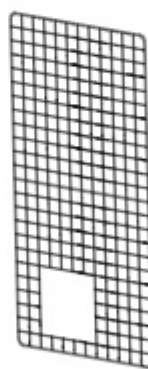

96x48 Tunnel
Connection Frame
079.1021
x1



Run Door Short Pin
300mm
810.0112
x2

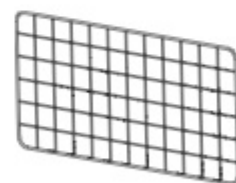

24x48 Panel
079.1006
x2

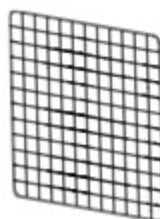

48x48 Panel
079.1000
x1

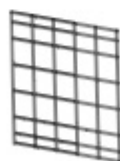

Tunnel
Connection Door
079.1020
x1

810.0424.067000: Bagged Run Clips



Run Clip
810.0135
x67

810.0138: Bagged Omlet Badge



Omlet Badge
810.0137
x2

079.0013: Roof Starter Pack

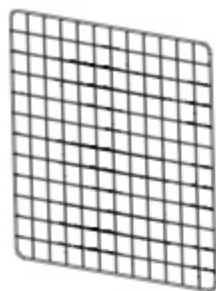

48x48 Panel
079.1000
x6



Beam End
Panel
079.0102
x2



Beam Middle
Panel
079.0103
x1



Gable Triangular
Panel
079.1008
x4

079.0050: Beam Fixings Pack 4 Bolts



Machine
Screw
M6x12mm
800.0242
x4



Wing Nut
800.0040
x4

810.0424.076000: Bagged Run Clips



Run Clip
810.0135
x76

079.0009: Underfloor Mesh Panel 6-Pack

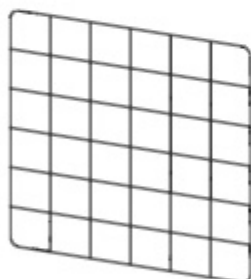

48x48 Underfloor Mesh
Panel
079.1014
x6

810.0424.054000: Bagged Run Clips



Run Clip
810.0135
x54

079.0010: Skirt Starter Pack



Skirt Corner Panel
079.1018
x4

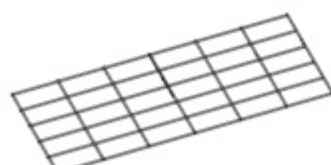

Skirt Panel
079.1016
x6



Skirt Support
041.1008
x2

810.0424.065000: Bagged Run Clips



Run Clip
810.0135
x65

Extending your Starter Pack

DE Erweitern Sie Ihr Starterpack • **FR** Extension de votre pack de démarrage • **NL** Uw starterspakket uitbreiden
IT Amplia il tuo starter pack • **ES** Cómo extender su pack de inicio • **SE** Förläng ditt startpaket
DK Udvidelse af begynder sæt

Zippi Mesh Extensions - Single Height

DE Zippi Auslauf Erweiterungen - Einfache Höhe • **FR** Extensions de grillage Zippi - Hauteur simple
NL Zippi gaasuitbreidingen - Enkele hoogte • **IT** Estensioni rete Zippi - Altezza singola
ES Extensiones de malla Zippi - Altura simple • **SE** Zippi förlängningssets i nät - enkel höjd
DK Zippi net udvidelser - den lave

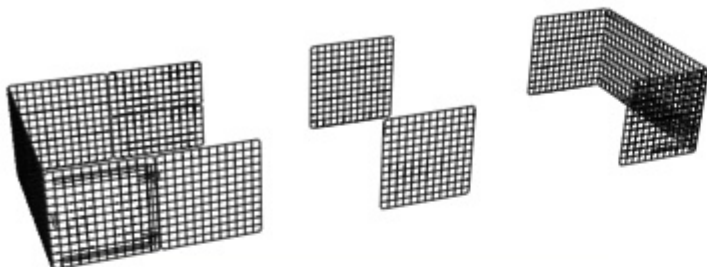

079.0003: 48x48 Panel 2-Pack

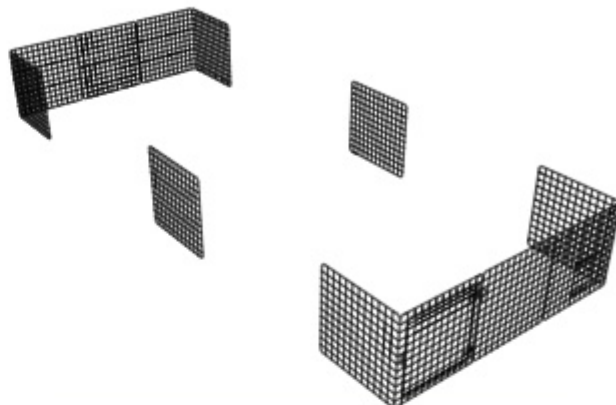

079.0003: 48x48 Panel 2-Pack



079.0004: 48x48 Panel 4-Pack

+ 079.0014: Middle Beam Pack

+ 079.0007: Underfloor Mesh Panel 2-Pack



079.0003: 48x48 Panel 2-Pack

+ 079.0015: Roof Extension Pack

+ 079.0008: Underfloor Mesh Panel

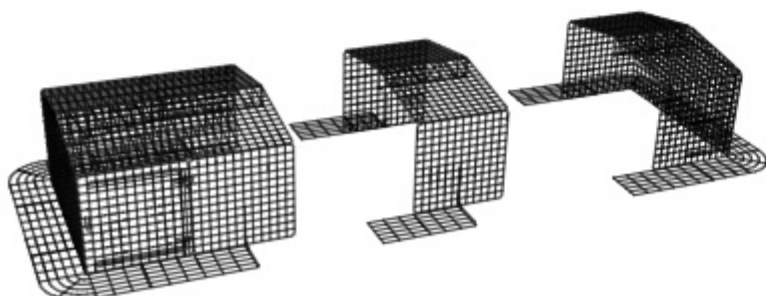

079.0004: 48x48 Panel 4-Pack

+ 079.0014: Middle Beam Pack

+ 079.0011: Skirt Panel 2-Pack

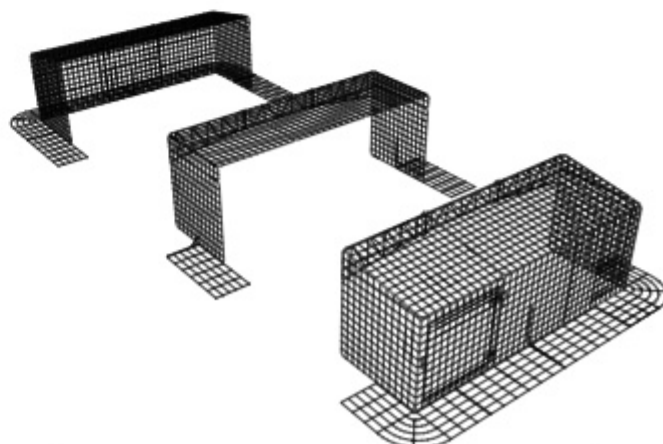

079.0003: 48x48 Panel 2-Pack

+ 079.0015: Roof Extension Pack

+ 079.0011: Skirt Panel 2-Pack

Zippi Mesh Extensions - Double Height

DE Zippi Auslauf Erweiterungen - Doppelte Höhe • **FR** Extensions de grillage Zippi - Hauteur double
NL Zippi gaasuitbreidingen - Dubbele hoogte • **IT** Estensioni rete Zippi - Altezza doppia
ES Extensiones de malla Zippi - Altura doble • **SE** Zippi förlängningssats i nät - dubbel höjd
DK Zippi net udvidelser - den høje

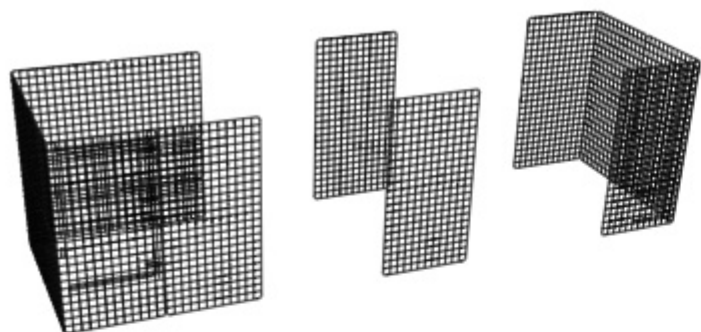

079.0005: 96x48 Panel 2-Pack

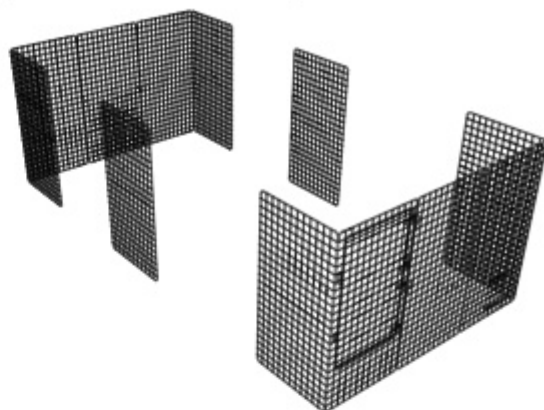

079.0005: 96x48 Panel 2-Pack

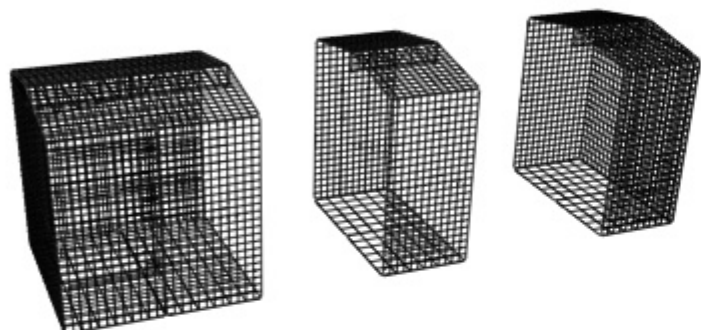

079.0005: 96x48 Panel 2-Pack

+ 079.0003: 48x48 Panel 2-Pack

+ 079.0014: Middle Beam Pack

+ 079.0007: Underfloor Mesh Panel 2-Pack

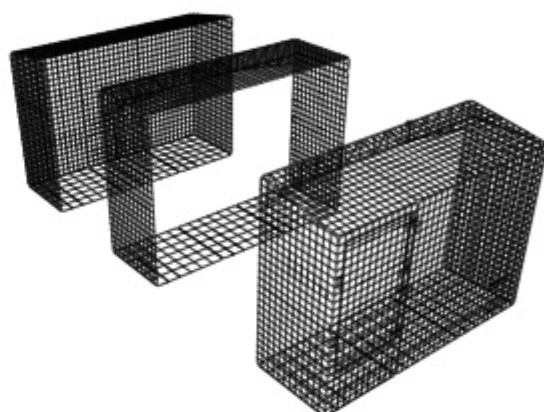

079.0005: 96x48 Panel 2-Pack

+ 079.0015: Roof Extension Pack

+ 079.0008: Underfloor Mesh Panel 4-Pack

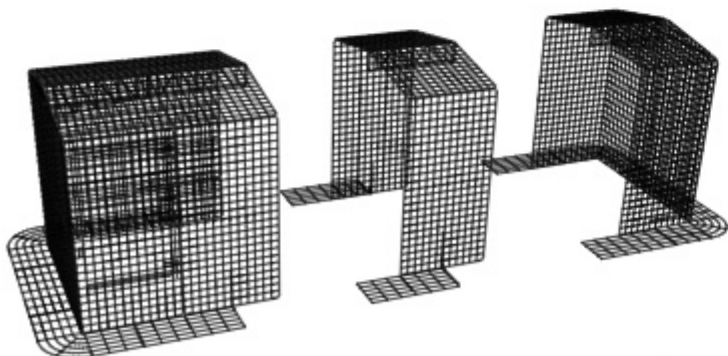

079.0005: 96x48 Panel 2-Pack

+ 079.0003: 48x48 Panel 2-Pack

+ 079.0014: Middle Beam Pack

+ 079.0011: Skirt Panel 2-Pack

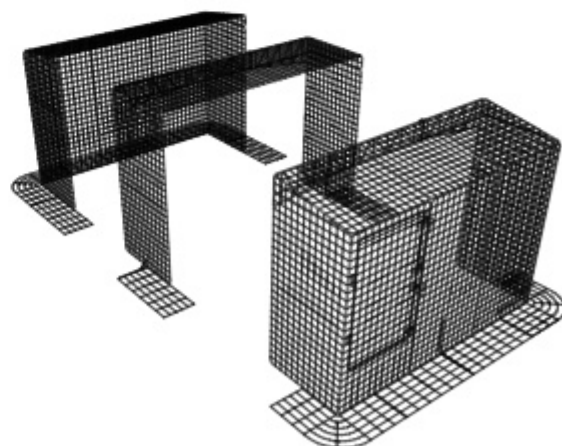









079.0005: 96x48 Panel 2-Pack

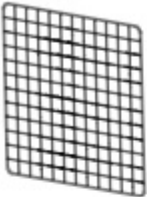

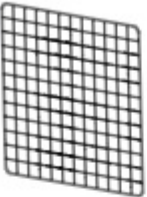
+ 079.0015: Roof Extension Pack

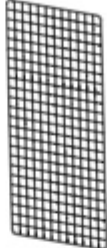

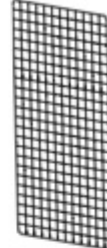



+ 079.0011: Skirt Panel 2-Pack

Extension Packs' Contents

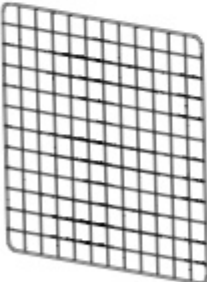
DE Inhalte der Erweiterungspacks • FR Contenu des packs d'extension • NL Inhoud uitbreidingspakket • IT Contenuti dei pacchi con estensioni • ES Contenidos de los packs de extensión • SE Förlängningssets innehåller
DK Udvidelsessæt indhold

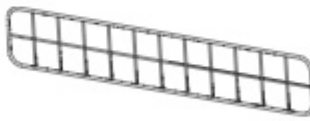
<p>079.0003: 48x48 Panel 2-Pack</p>  <p>48x48 Panel 079.1000 x2</p> <p>810.0424.017000: Bagged Run Clips</p>  <p>Run Clip 810.0135 x17</p>	<p>079.0004: 48x48 Panel 4-Pack</p>  <p>48x48 Panel 079.1000 x4</p> <p>810.0424.023000: Bagged Run Clips</p>  <p>Run Clip 810.0135 x23</p>	<p>079.0005: 96x48 Panel 2-Pack</p>  <p>96x48 Panel 079.1001 x2</p> <p>810.0424.011000: Bagged Run Clips</p>  <p>Run Clip 810.0135 x11</p>	<p>079.0006: 96x48 Panel 4-Pack</p>  <p>96x48 Panel 079.1001 x4</p> <p>810.0424.021000: Bagged Run Clips</p>  <p>Run Clip 810.0135 x21</p>
---	--	--	--

<p>079.0014: Middle Beam Pack</p>	
 <p>Beam Middle Panel 079.0103 x1</p>	<p>079.0051: Beam Fixings Pack 2 Bolts</p>  <p>Machine Screw M6x12mm 800.0242 x2</p>  <p>Wing Nut 800.0040 x2</p>

<p>079.0015: Roof Extension Pack</p>			
 <p>48x48 Panel 079.1000 x3</p>	 <p>Beam End Panel 079.0102 x2</p>	 <p>Beam Middle Panel 079.0103 x1</p>	 <p>Gable Rectangle Panel 079.1009 x2</p>
<p>810.0424.042000: Bagged Run Clips</p>  <p>Run Clip 810.0135 x42</p>	<p>079.0050: Beam Fixings Pack 4 Bolts</p>  <p>Machine Screw M6x12mm 800.0242 x4</p>  <p>Wing Nut 800.0040 x4</p>		

079.0008: Underfloor Mesh Panel 4-Pack

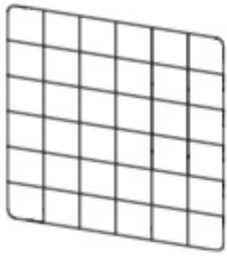

**810.0424.038000:
Bagged Run Clips**



48x48
Underfloor Mesh Panel
079.1014
x4

Run Clip
810.0135
x38

079.0007: Underfloor Mesh Panel 2-Pack

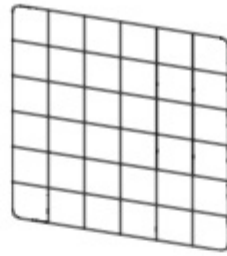

**810.0424.022000:
Bagged Run Clips**



48x48
Underfloor Mesh Panel
079.1014
x2

Run Clip
810.0135
x22

079.0012: Skirt Panel 4-Pack

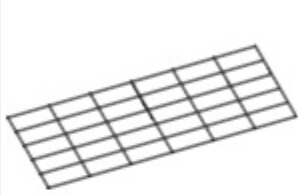

**810.0424.029000:
Bagged Run Clips**



Skirt Panel
079.1016
x4

Skirt Support
041.1008
x4

Run Clip
810.0135
x29

079.0011: Skirt Panel 2-Pack

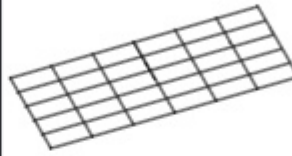

**810.0424.015000:
Bagged Run Clips**



Skirt Panel
079.1016
x2

Skirt Support
041.1008
x2

Run Clip
810.0135
x15

Extras

DE Extras • **FR** Extras • **NL** Extra's • **IT** Extra • **ES** Extras • **SE** Extra tillbehör • **DK** Ekstraudstyr

079.0021: 24x48 Panel 4-Pack

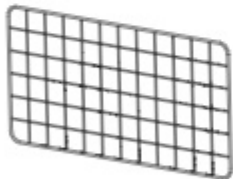

**810.0424.013000:
Bagged Run Clips**



24x48 Panel
079.1006
x4

Run Clip
810.0135
x13

079.0020: 24x48 Panel 2-Pack

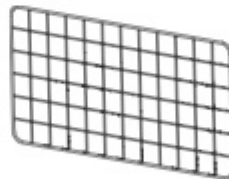

**810.0424.006000:
Bagged Run Clips**



24x48 Panel
079.1006
x2

Run Clip
810.0135
x6

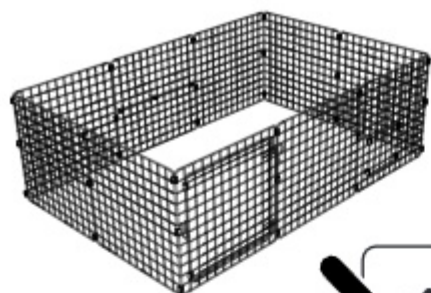

→ 1

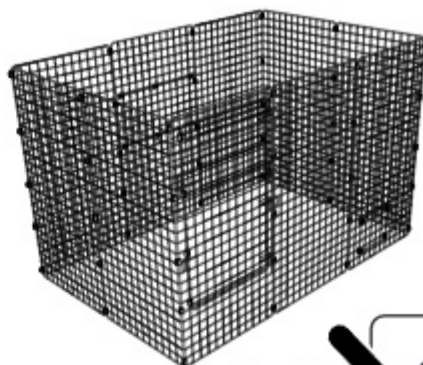

→ 8

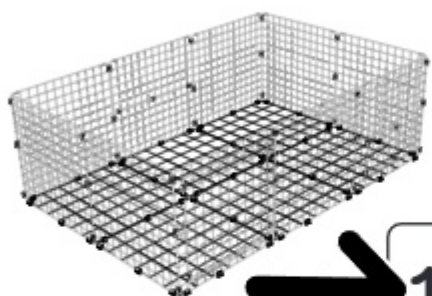

→ 15

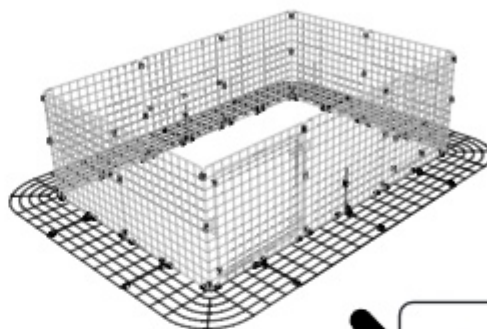

→ 17



→ 19

If the Zippi Run you are assembling is larger than 2 × 3 panels, please refer to the extension overviews on pages 7 and 8 and use them together with the following assembly instructions. The same assembly principles apply.



DE Wenn der Zippi Auslauf, den Sie zusammenbauen, größer als 2 × 3 Abschnitte ist, sehen Sie bitte die Übersichten zu den Erweiterungen auf den Seiten 7 und 8 und verwenden Sie diese zusammen mit der folgenden Montageanleitung. Es gelten dieselben Montageprinzipien.

FR Si l'enclos Zippi que vous assemblez comporte plus que 2×3 panneaux, veuillez vous référer aux schémas des extensions aux pages 7 et 8 et les utiliser en complément des instructions de montage suivantes. Les mêmes principes de montage s'appliquent.

NL Als de Zippi ren die je in elkaar zet groter is dan 2 × 3 panelen, raadpleeg dan de overzichten van de uitbreidingspanelen op pagina 7 en 8 en gebruik deze samen met de volgende montage-instructies. Dezelfde montageprincipes zijn van toepassing.

IT Se il recinto Zippi che state assemblando ha più di 2×3 pannelli, fate riferimento agli schemi per le estensioni alle pagine 7 e 8 e utilizzateli insieme alle seguenti istruzioni di montaggio. I principi di assemblaggio rimangono gli stessi.

ES Si el Zippi Run que está montando cuenta con más de 2 × 3 paneles, consulte las indicaciones específicas para extensiones en las páginas 7 y 8 y utilícelas junto con las siguientes instrucciones de montaje. Se aplican los mismos principios de montaje.

SE Om Zippi-gården du bygger ihop är större än 2×3 paneler ska du bläddra till översikten för förläggningar på sidorna 7 och 8, och använda dem tillsammans med följande instruktioner. Samma princip för monteringen gäller oavsett hur stor gården är.

DK Hvis din Zippi løbegård er større end 2×3 paneler, bedes du se oversigterne over forlængelser på side 7 og 8 og anvende dem sammen med følgende vejledning. De samme principper for bygning og montering gælder.

1

Starter Pack Low

Use this diagram for exact clip positions

DE Nutzen Sie diese Übersicht für die Positionierung der Clips • **FR** Référez-vous à ce schéma pour repérer la position exacte des fixations • **NL** Gebruik dit schema voor de juiste positie van de clips • **IT** Usate questo diagramma per il posizionamento delle clip • **ES** Utilice este diagrama para conocer las posiciones exactas de los enganches • **SE** Använd detta diagram för att se exakta positioner för clipsen • **DK** Anvend dette diagram for at se præcise placeringer af klemmer

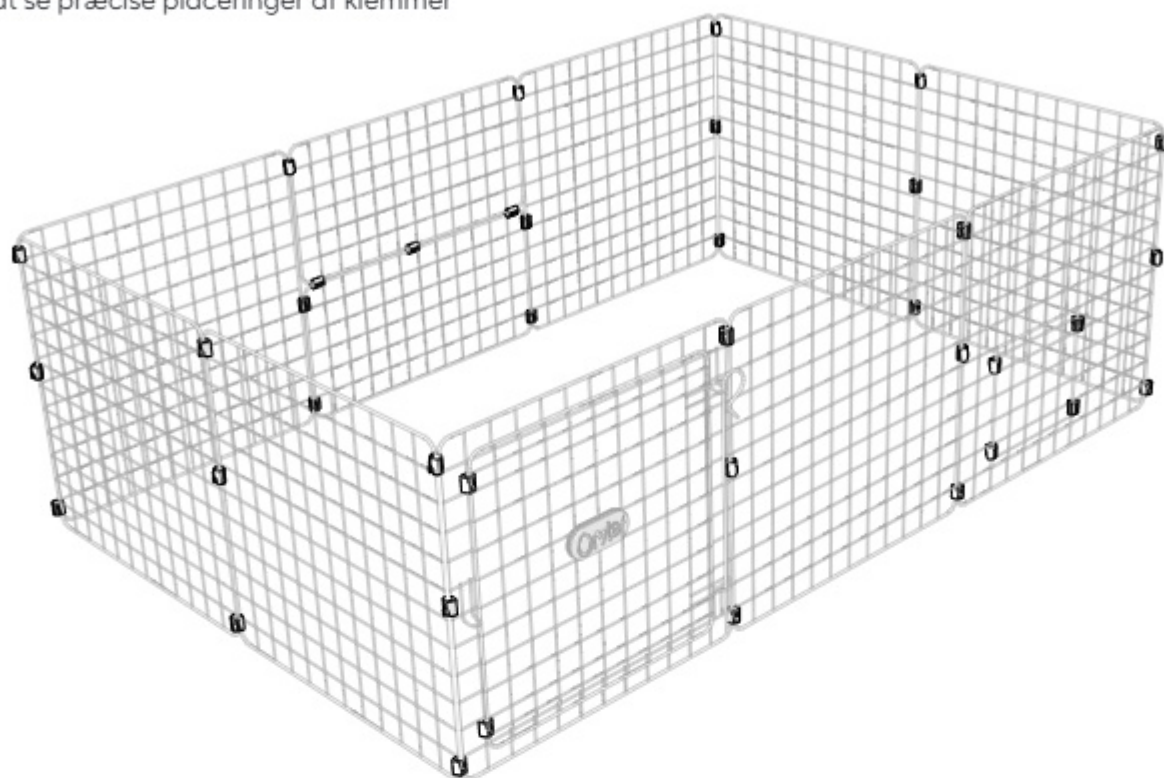

2

Lay the panels out on the ground as shown

DE Legen Sie die Paneele vor sich auf den Boden • **FR** Disposez les panneaux sur le sol comme ceci • **NL** Leg de panelen op de grond zoals weergegeven • **IT** Posizionate i pannelli per terra come da figura • **ES** Colocar los paneles en el suelo como se muestra • **SE** Lägg ut panelerna på marken enligt bilden • **DK** Læg panelerne ud på jorden som vist

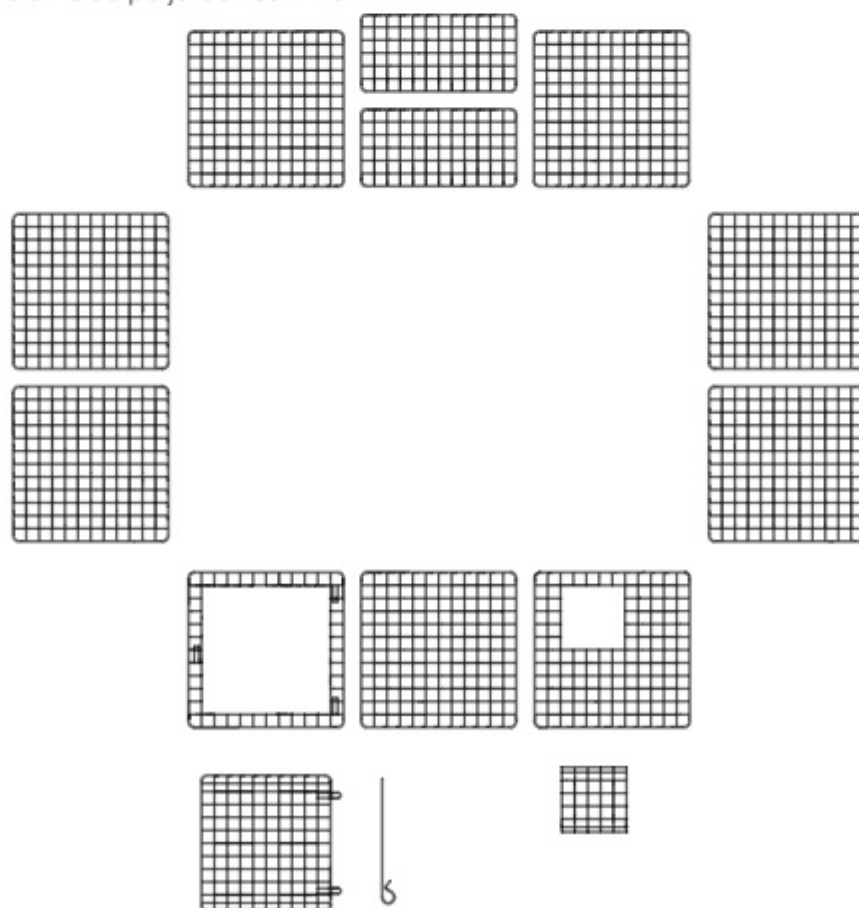

3

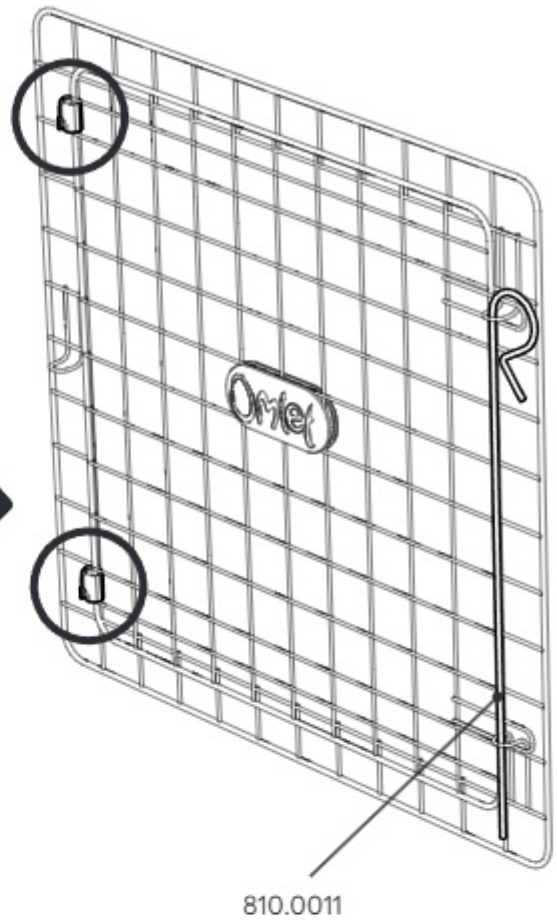
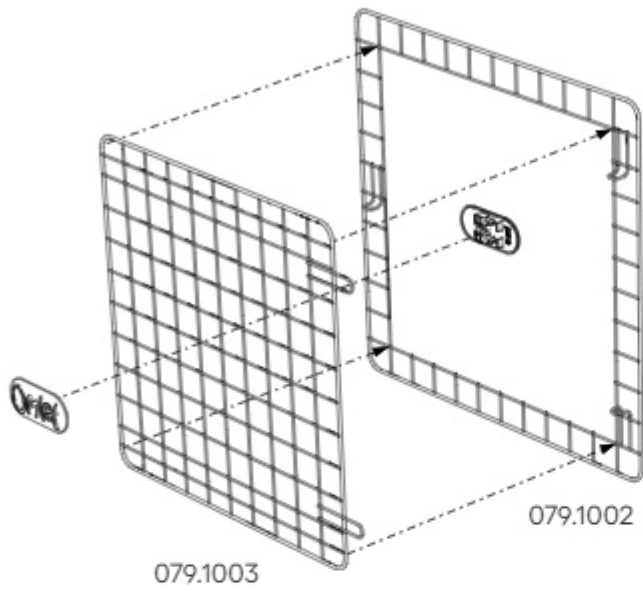
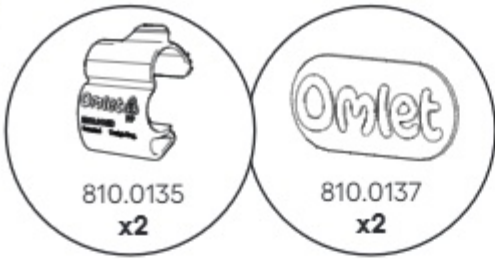

4

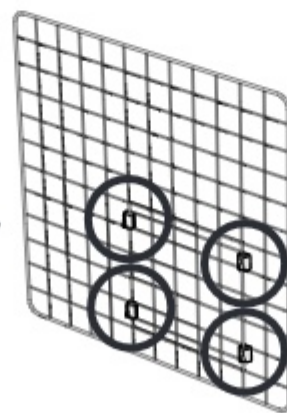
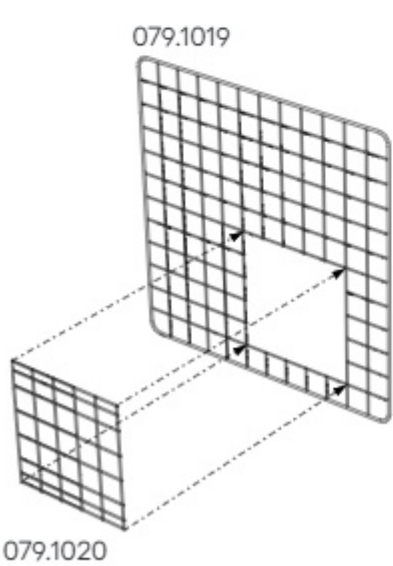

or
oder
ou
of
oppure
o
eller
lub

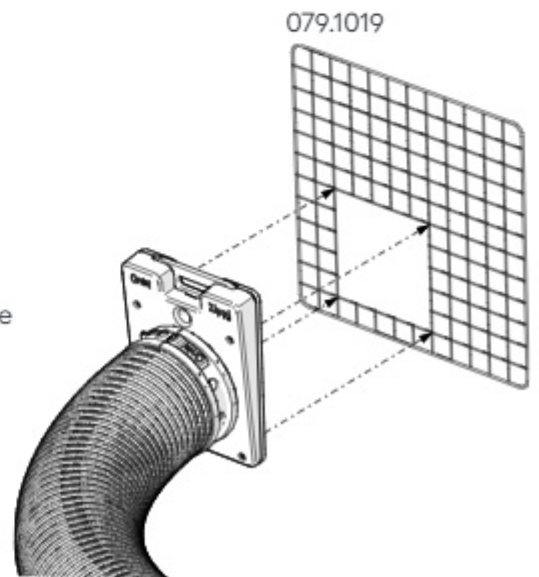

5

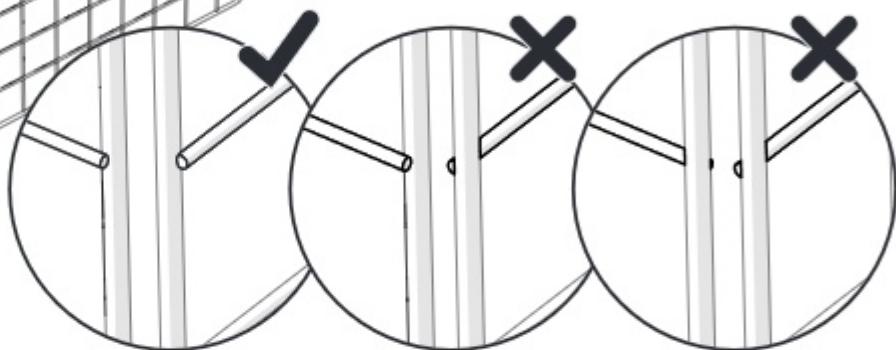
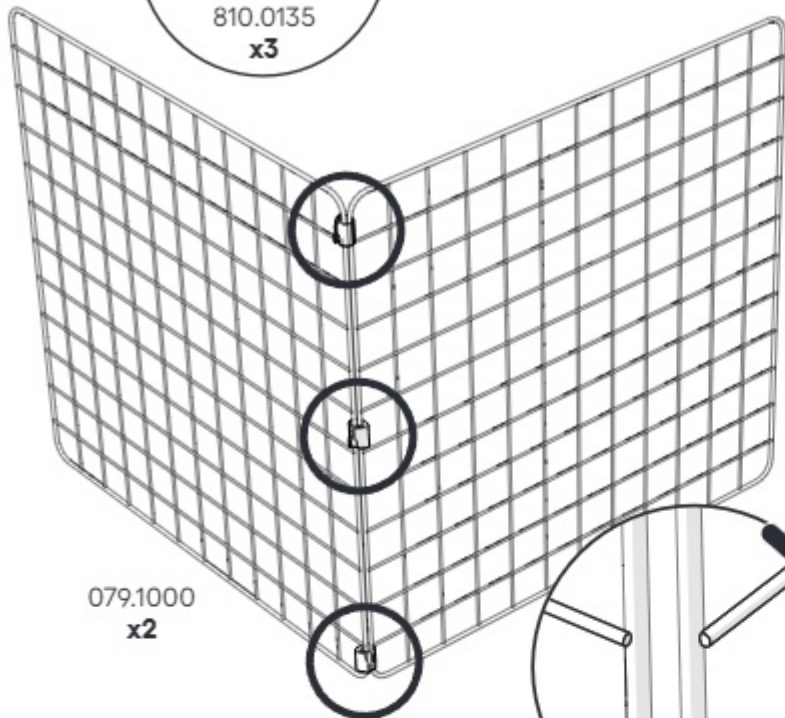

6

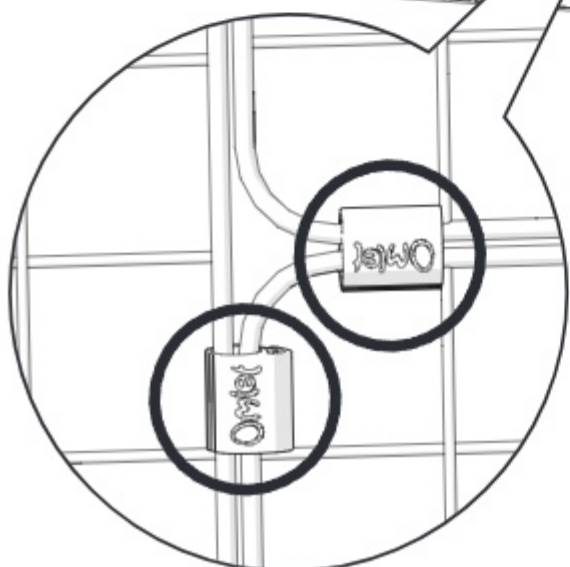
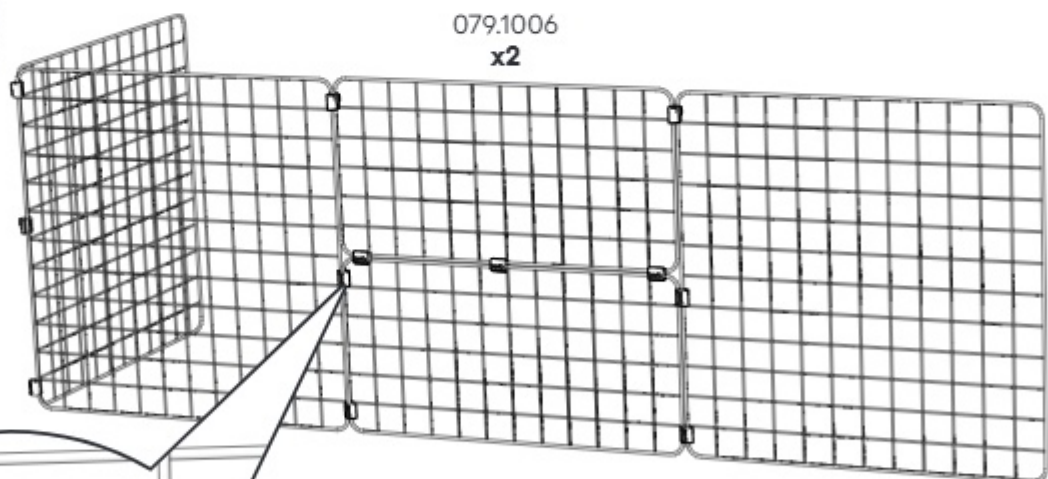

7**Easy access panel**

DE Schnell-Zugangs-Paneel • **FR** Accès facile à l'enclos • **NL** Paneel voor snelle toegang
IT Pannello per facile accesso • **ES** Panel de fácil acceso
SE Panel för lätt åtkomst • **DK** Panel der giver nem adgang

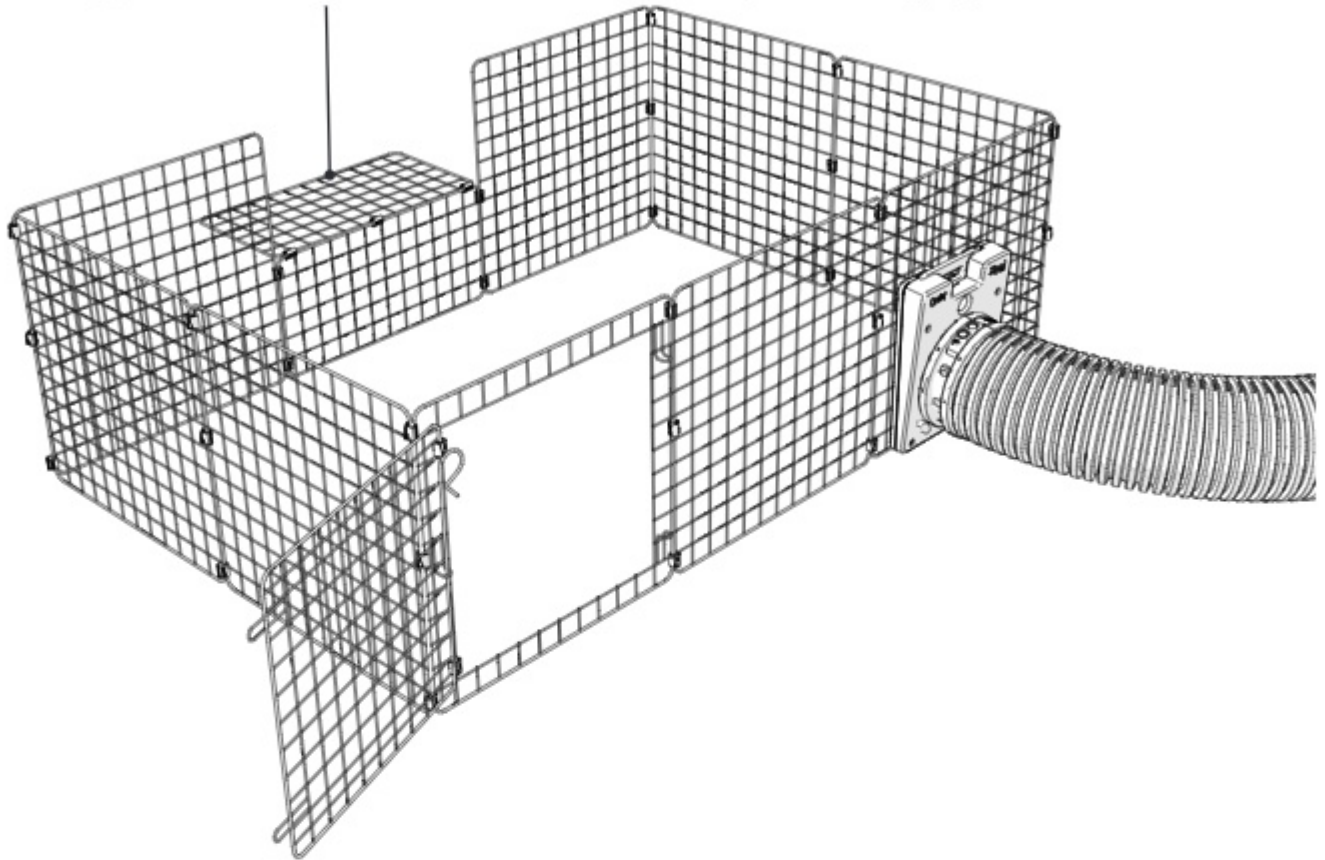
**8****Starter Pack High****Use this diagram for exact clip positions**

DE Nutzen Sie diese Übersicht für die Positionierung der Clips • **FR** Référez-vous à ce schéma pour repérer la position exacte des fixations • **NL** Gebruik dit schema voor de juiste positie van de clips • **IT** Usate questo diagramma per il posizionamento delle clip • **ES** Utilice este diagrama para conocer las posiciones exactas de los enganches • **SE** Använd detta diagram för att se exakta positioner för clipsen • **DK** Anvend dette diagram for at se præcise placeringer af klemmer

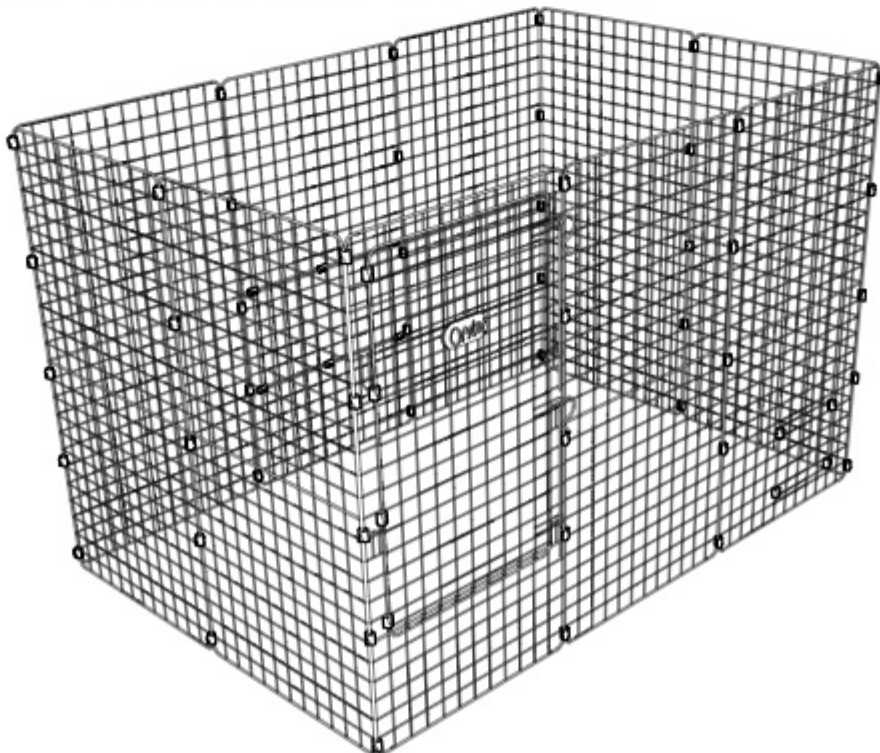

9**Lay the panels out on the ground as shown**

DE Legen Sie die Paneele vor sich auf den Boden • **FR** Disposez les panneaux sur le sol comme ceci
NL Leg de panelen op de grond zoals weergegeven • **IT** Posizionate i pannelli per terra come da figura
ES Colocar los paneles en el suelo como se muestra • **SE** Lägg ut panelerna på marken enligt bilden
DK Læg panelerne ud på jorden som vist

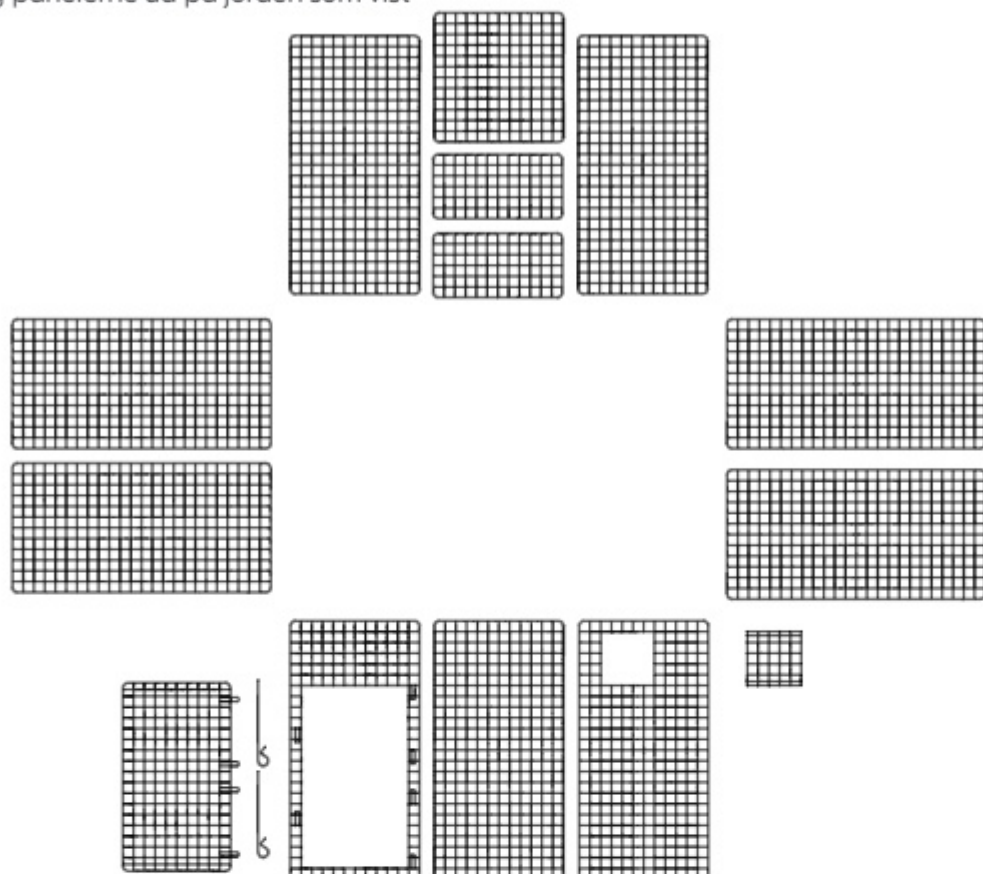
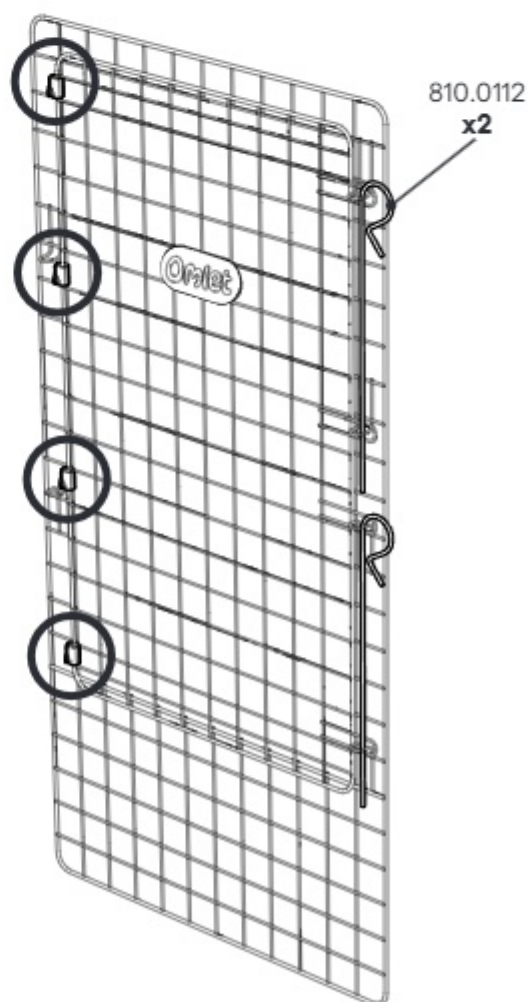
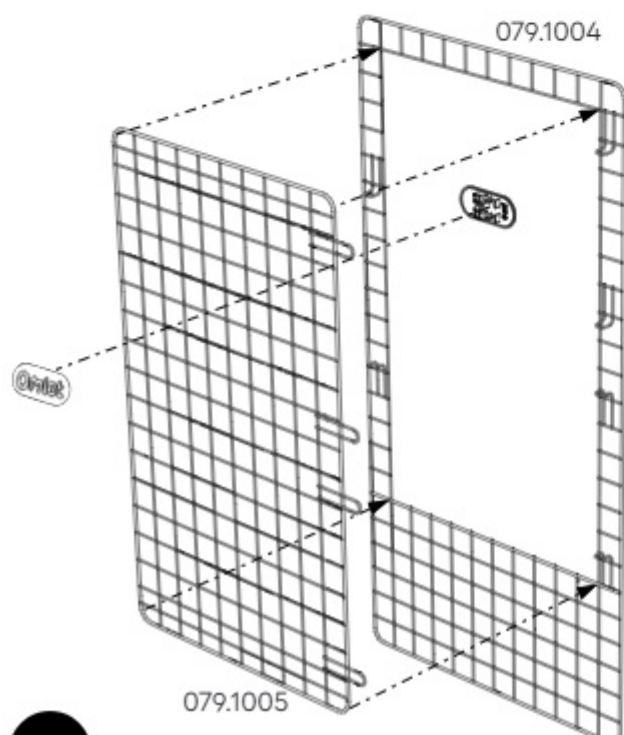
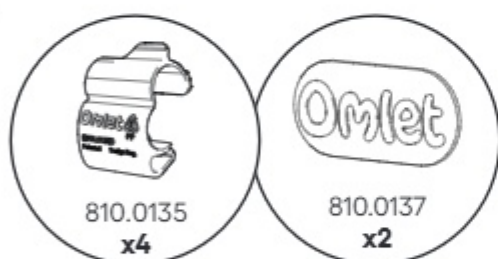
**10****16**

11

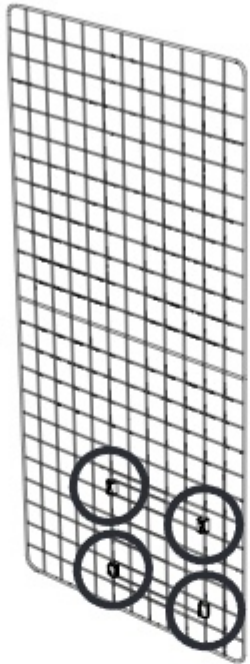
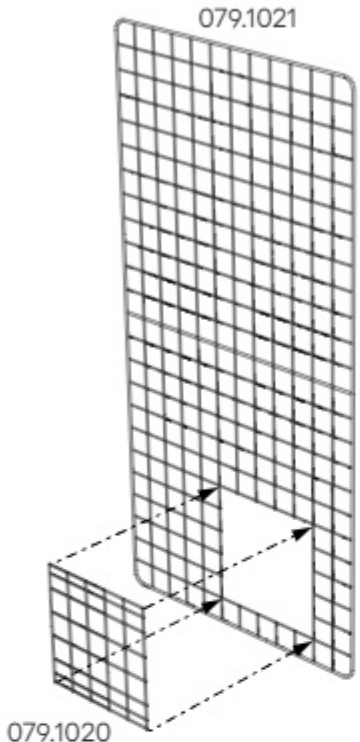

or
oder
ou
of
oppure
o
eller
lub

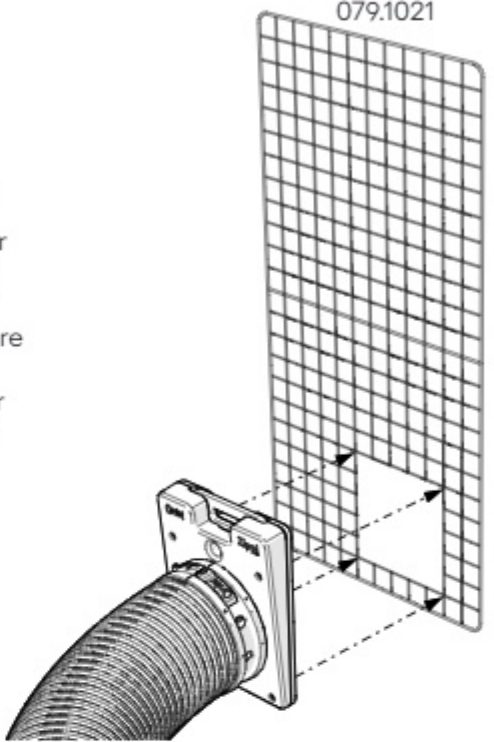

12

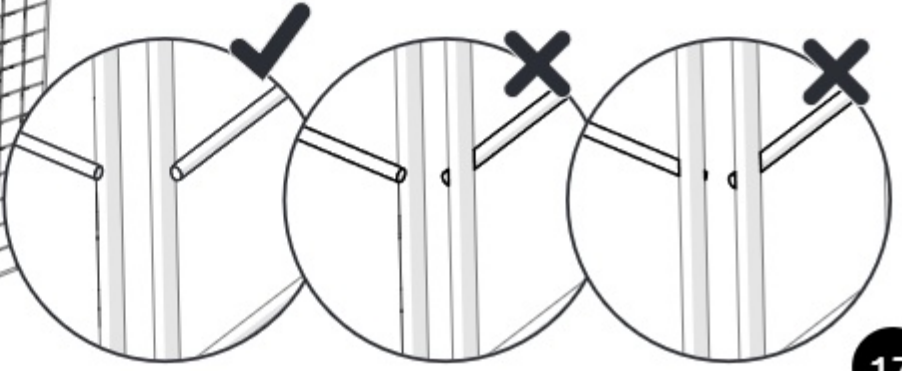
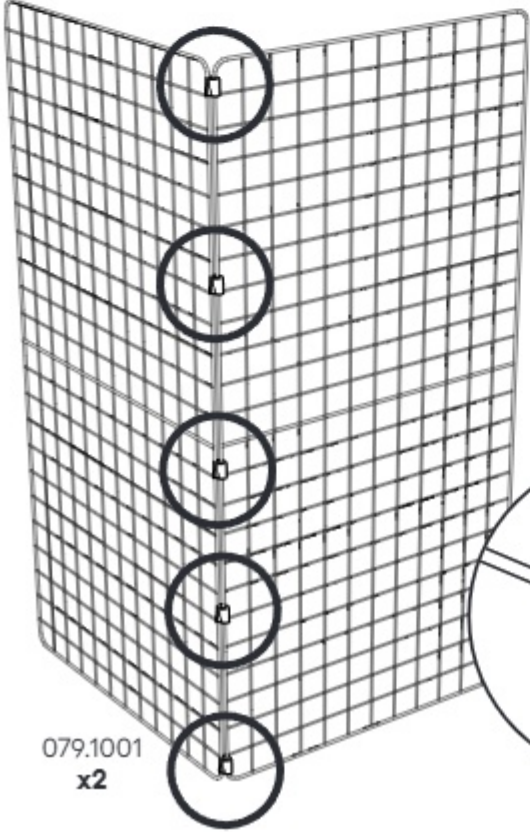

13

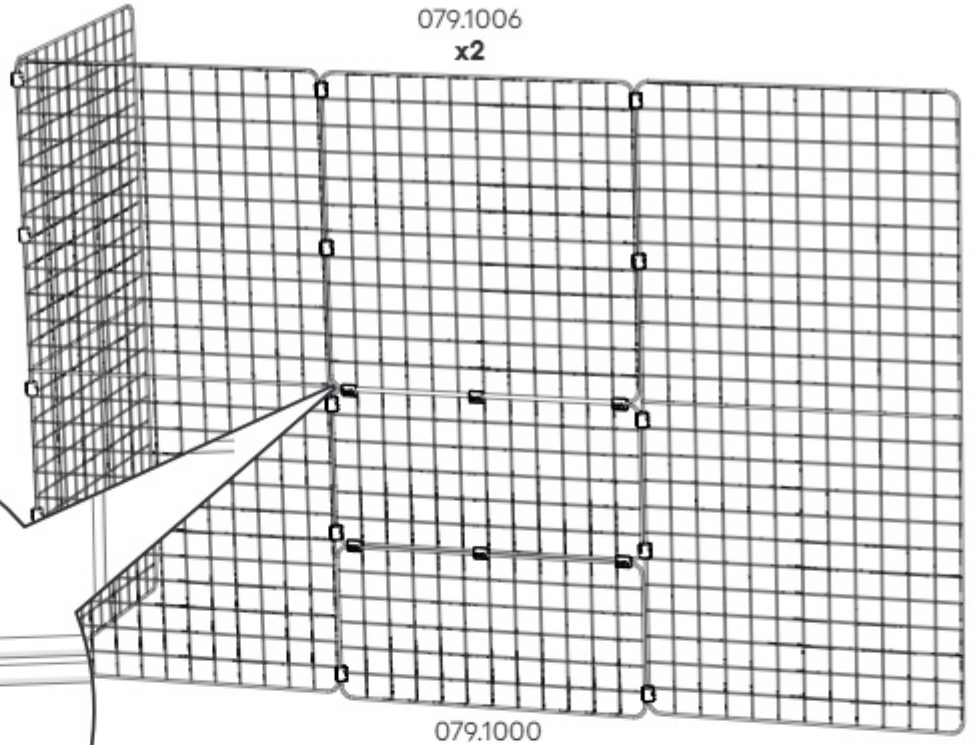
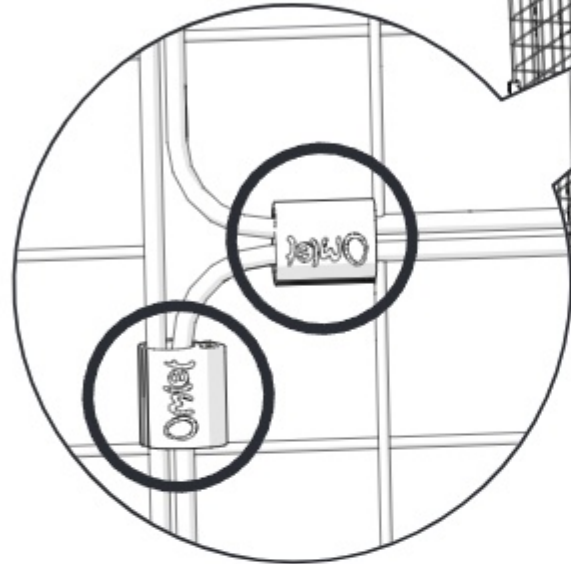

14

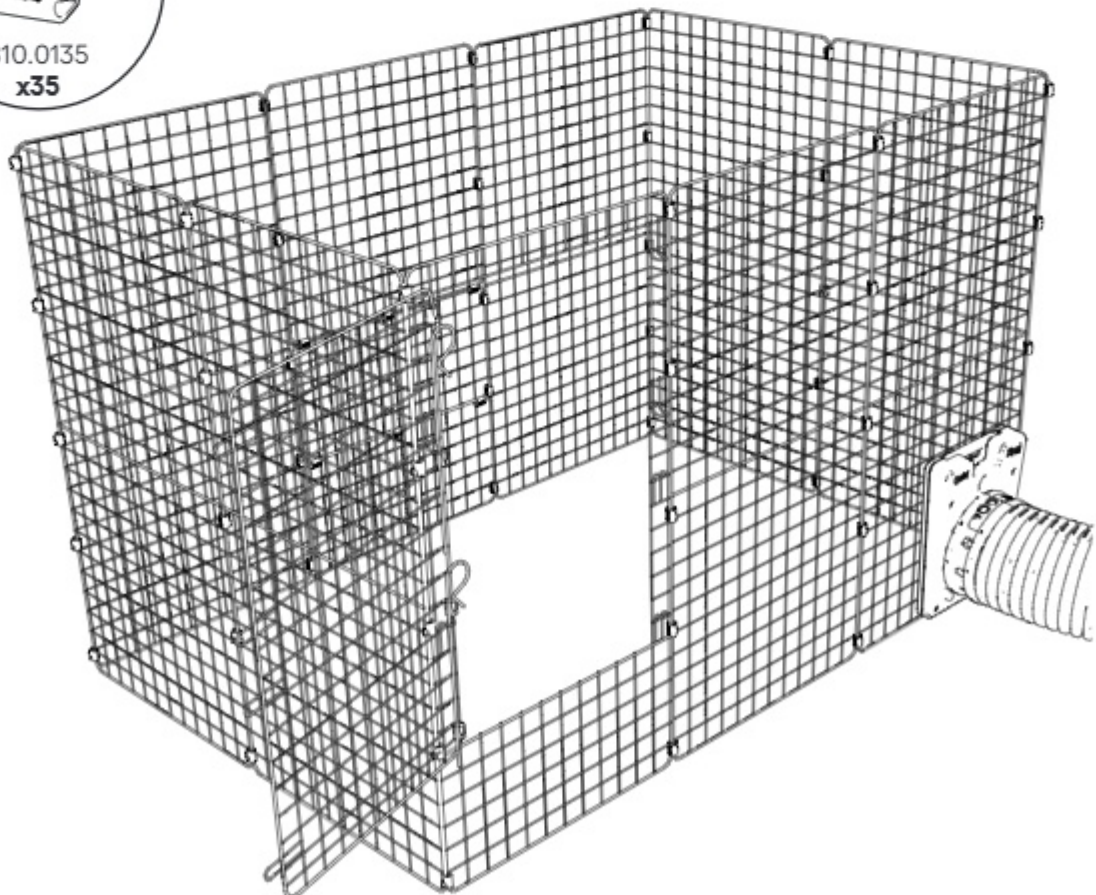

15

Underfloor Mesh Panel 6-Pack

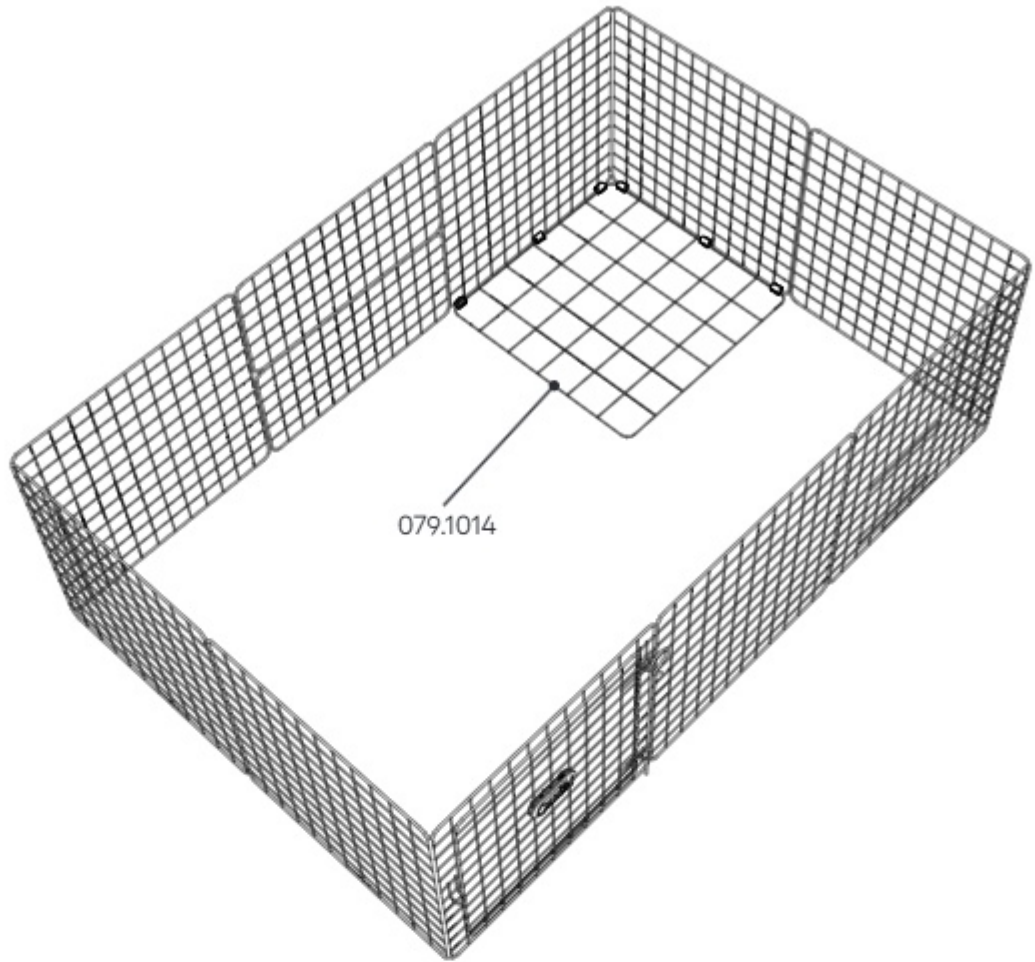

16

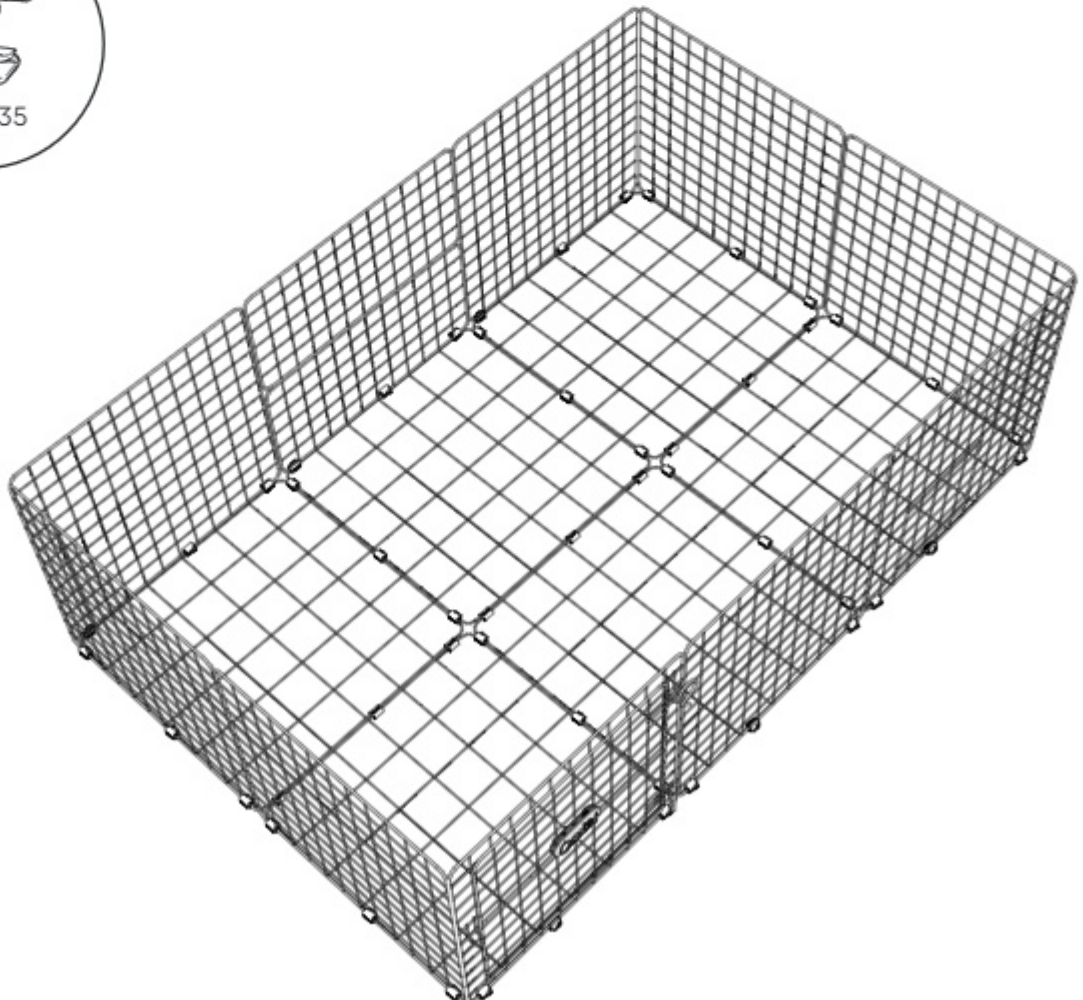

17

Skirt Starter Pack

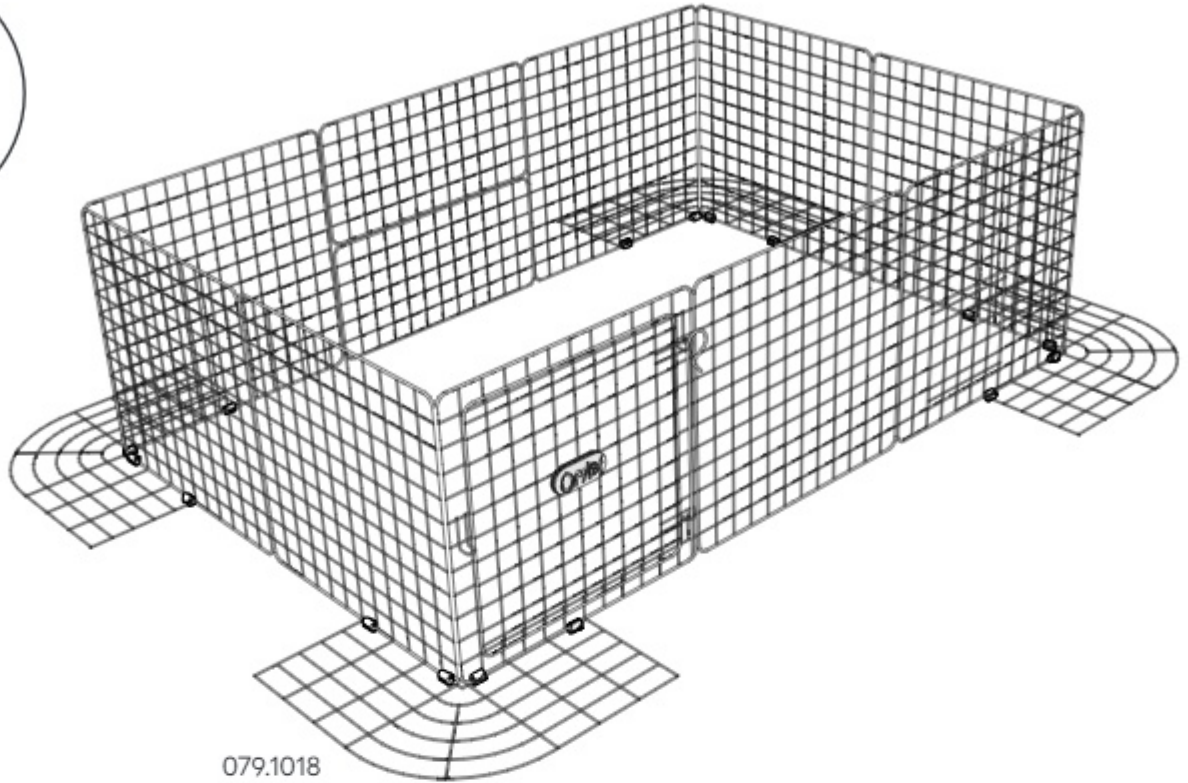

18

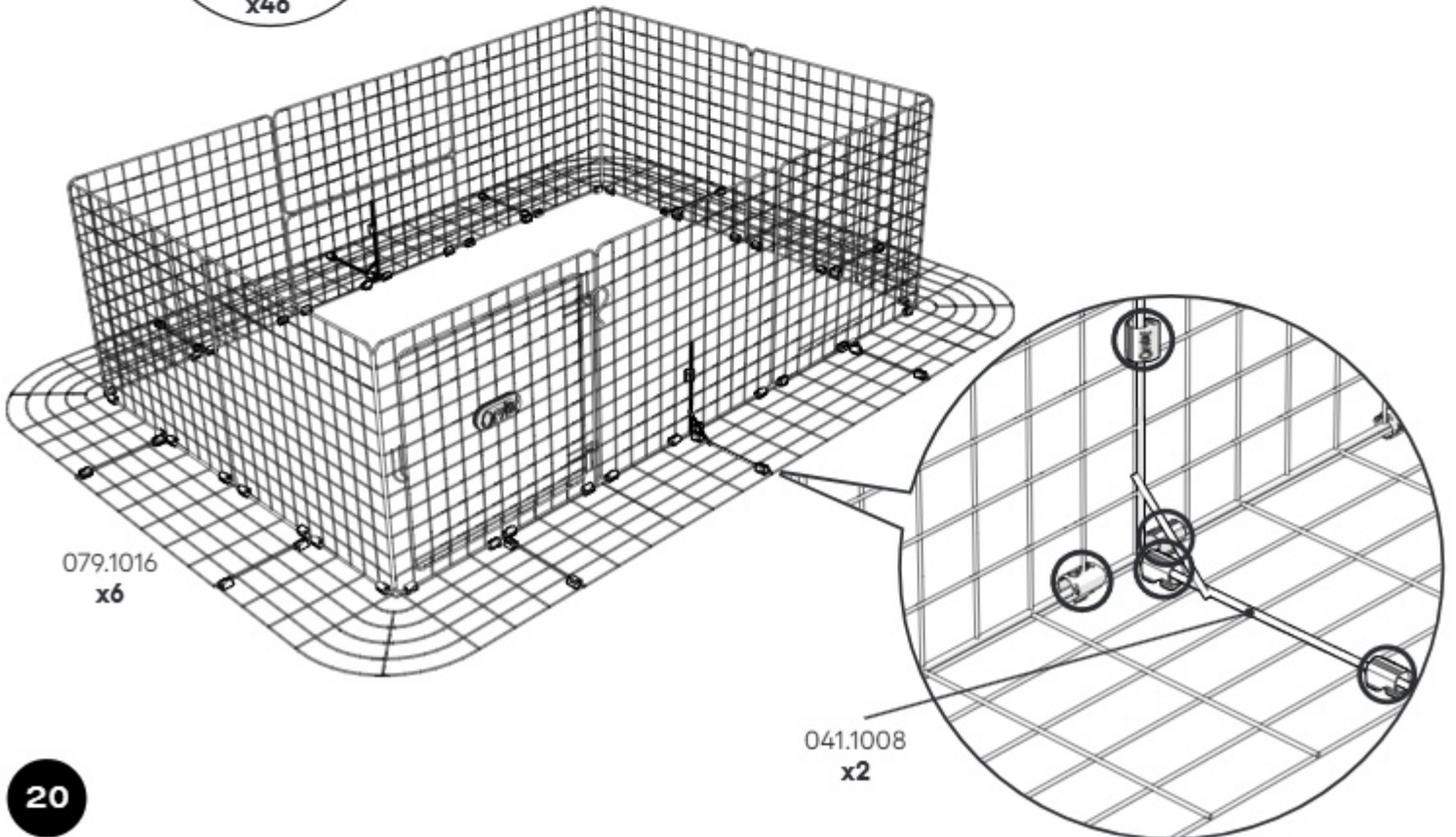

DE Nutzen Sie diese Übersicht für die Positionierung der Clips • **FR** Référez-vous à ce schéma pour repérer la position exacte des fixations • **NL** Gebruik dit schema voor de juiste positie van de clips • **IT** Usate questo diagramma per il posizionamento delle clip • **ES** Utilice este diagrama para conocer las posiciones exactas de los enganches • **SE** Använd detta diagram för att se exakta positioner för clipsen • **DK** Anvend dette diagram for at se præcise placeringer af klemmer

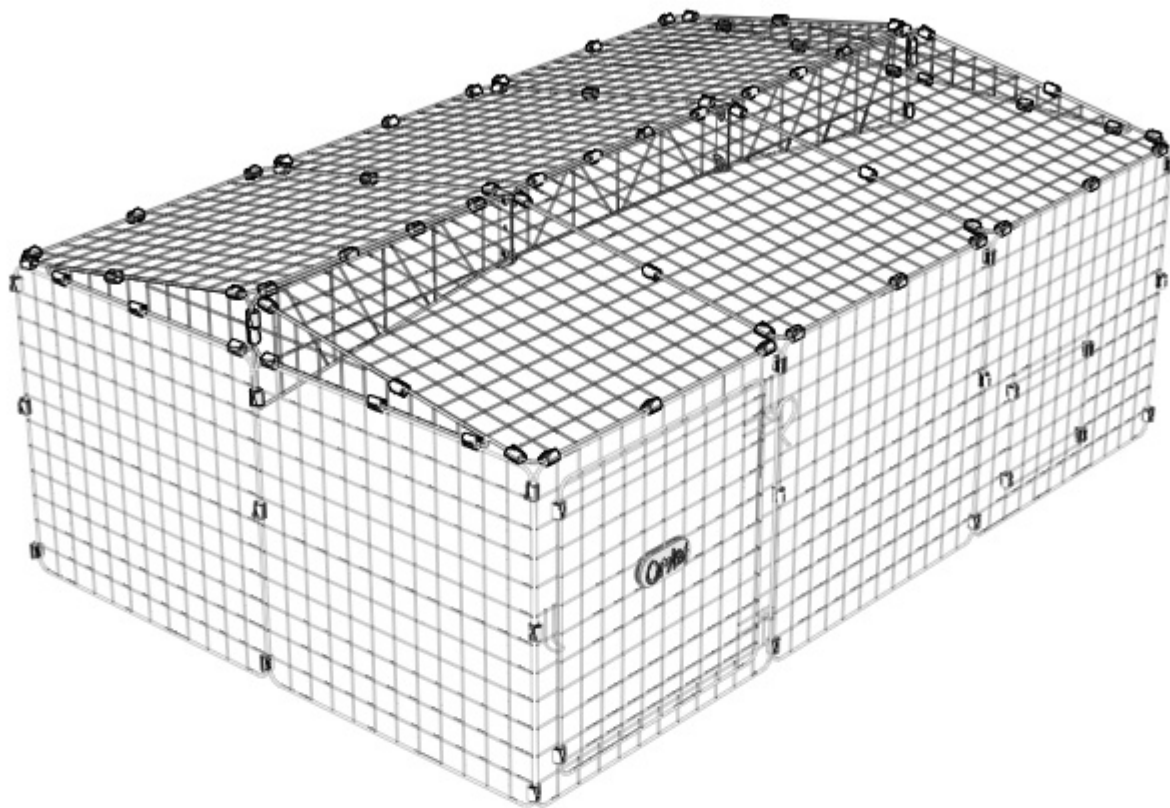

079.1008
x4

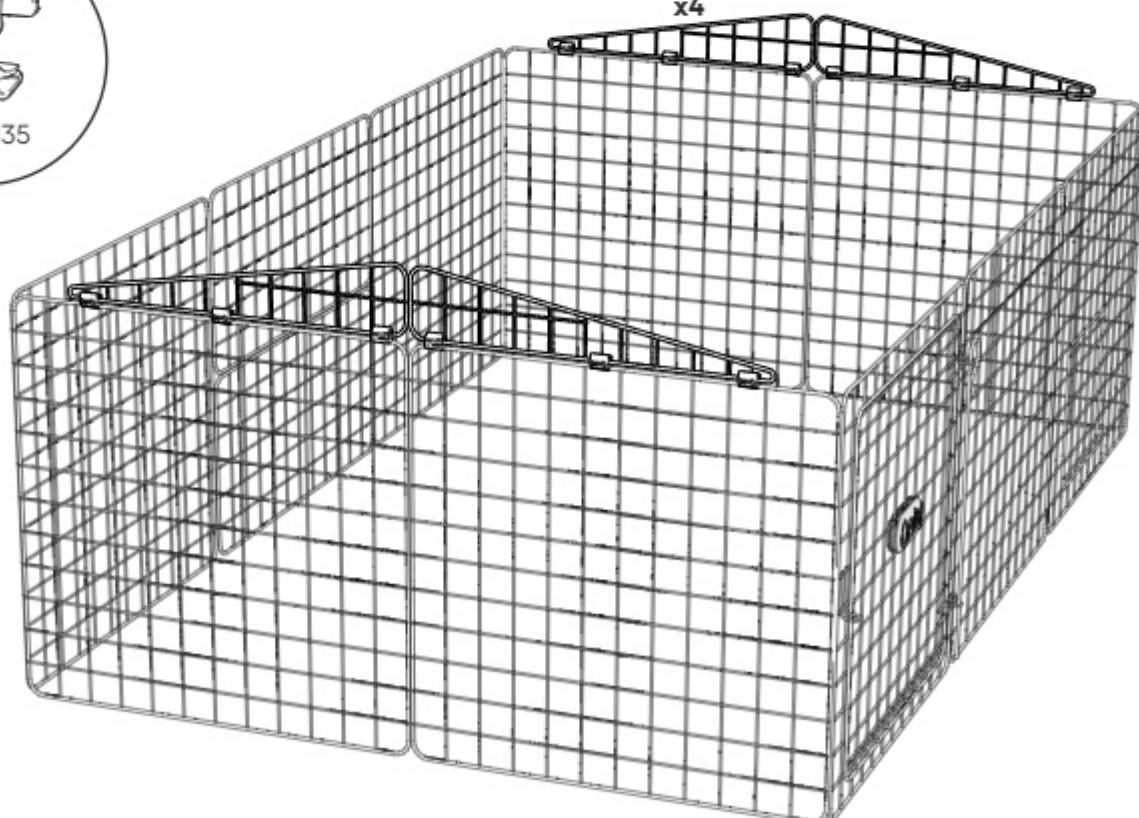

22

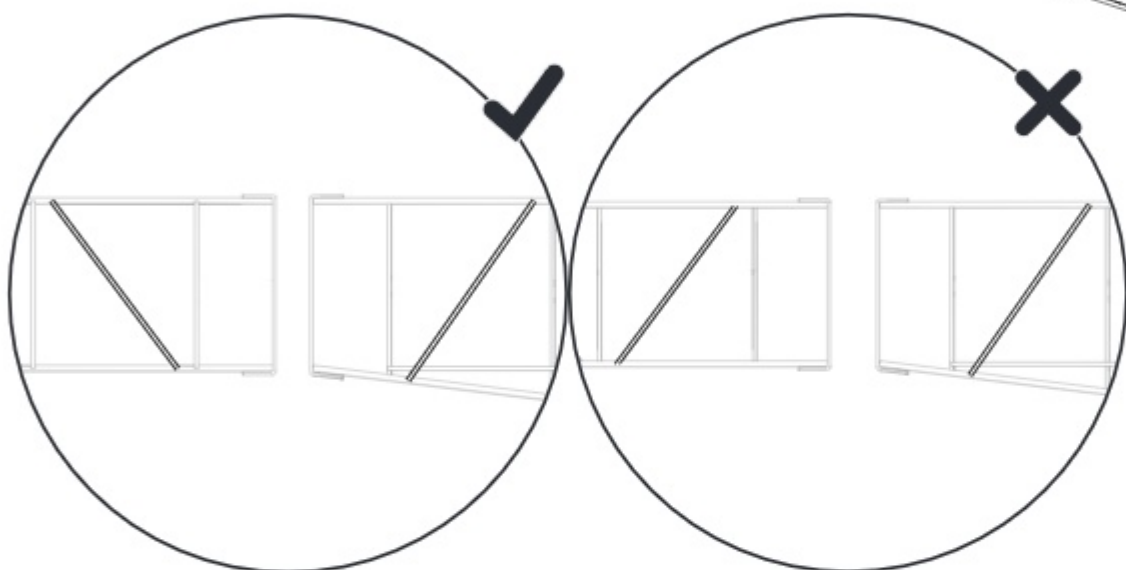
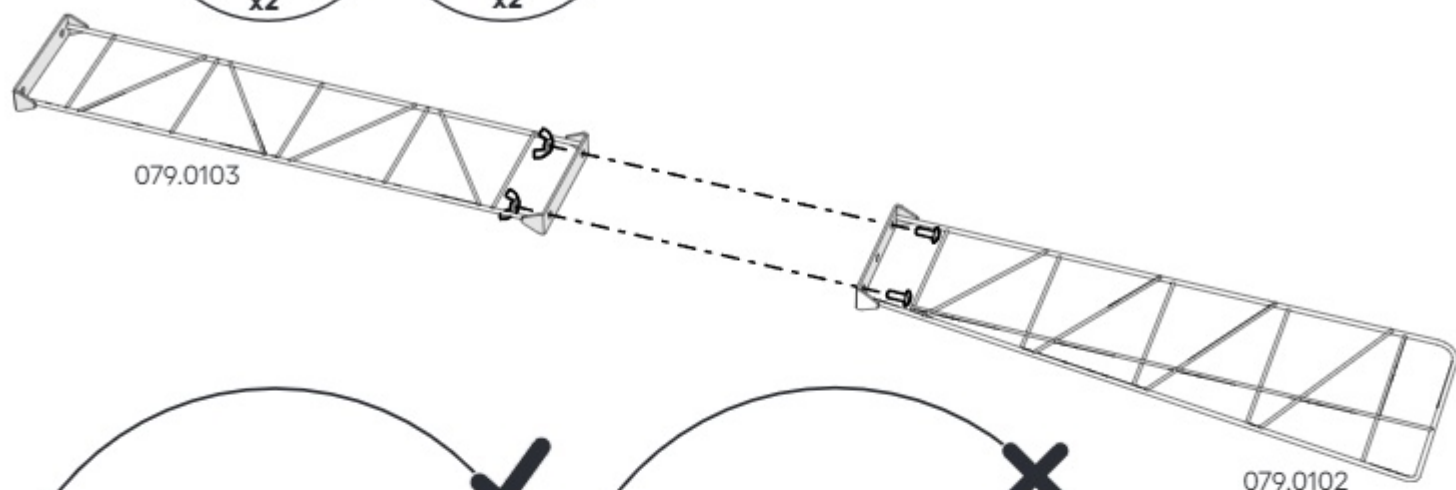
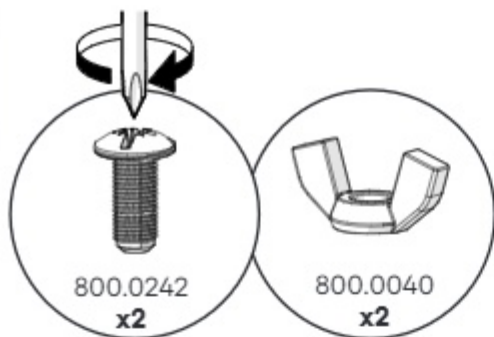

23

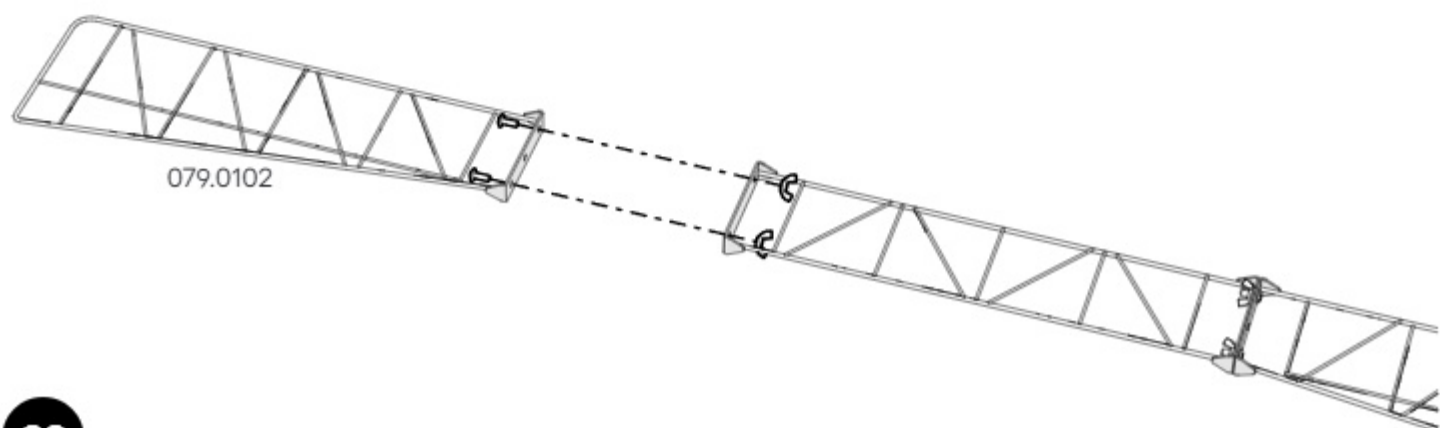
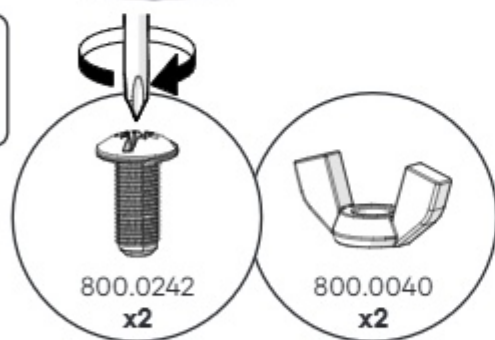

24

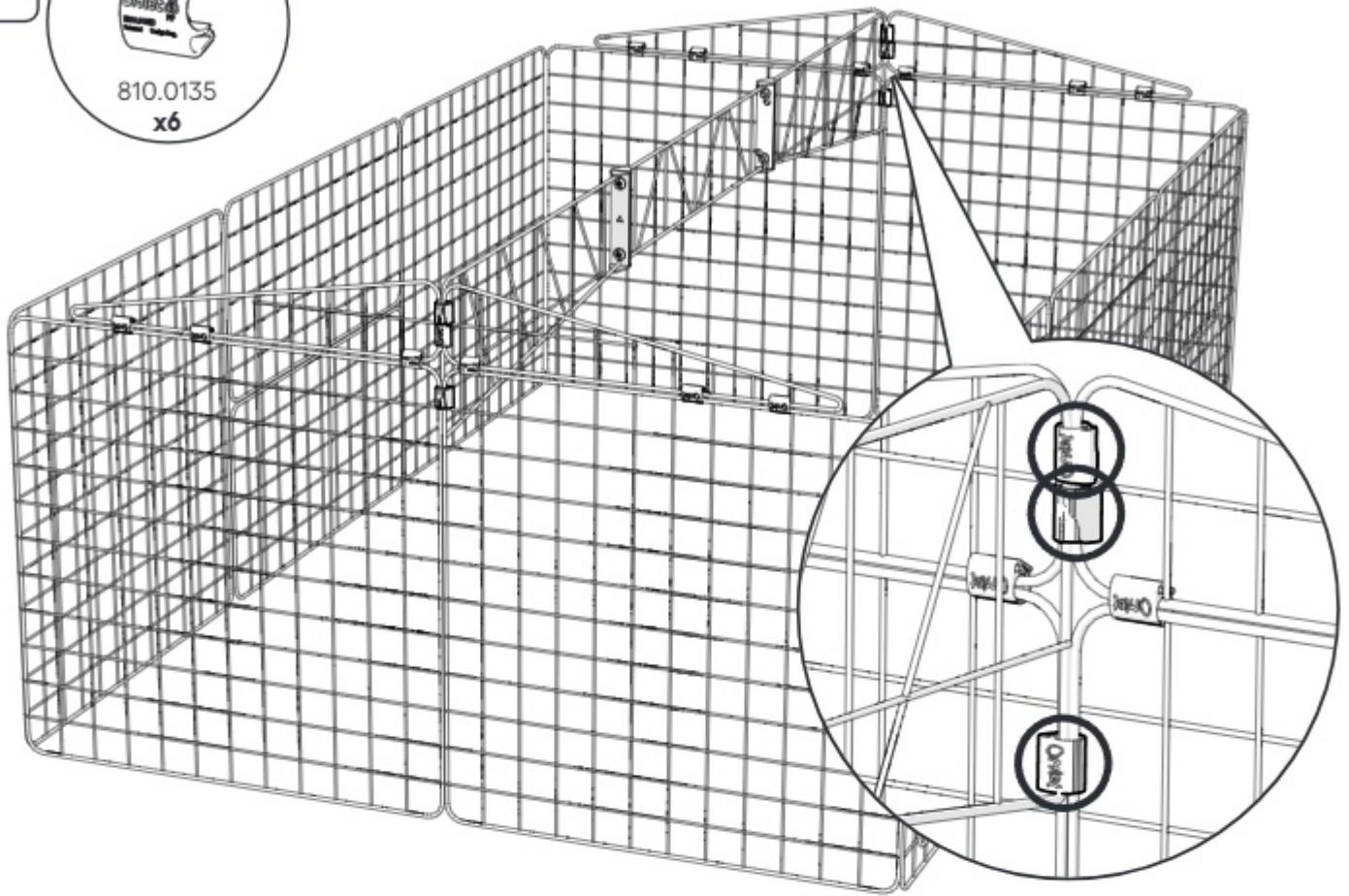

25



079.1000
x2

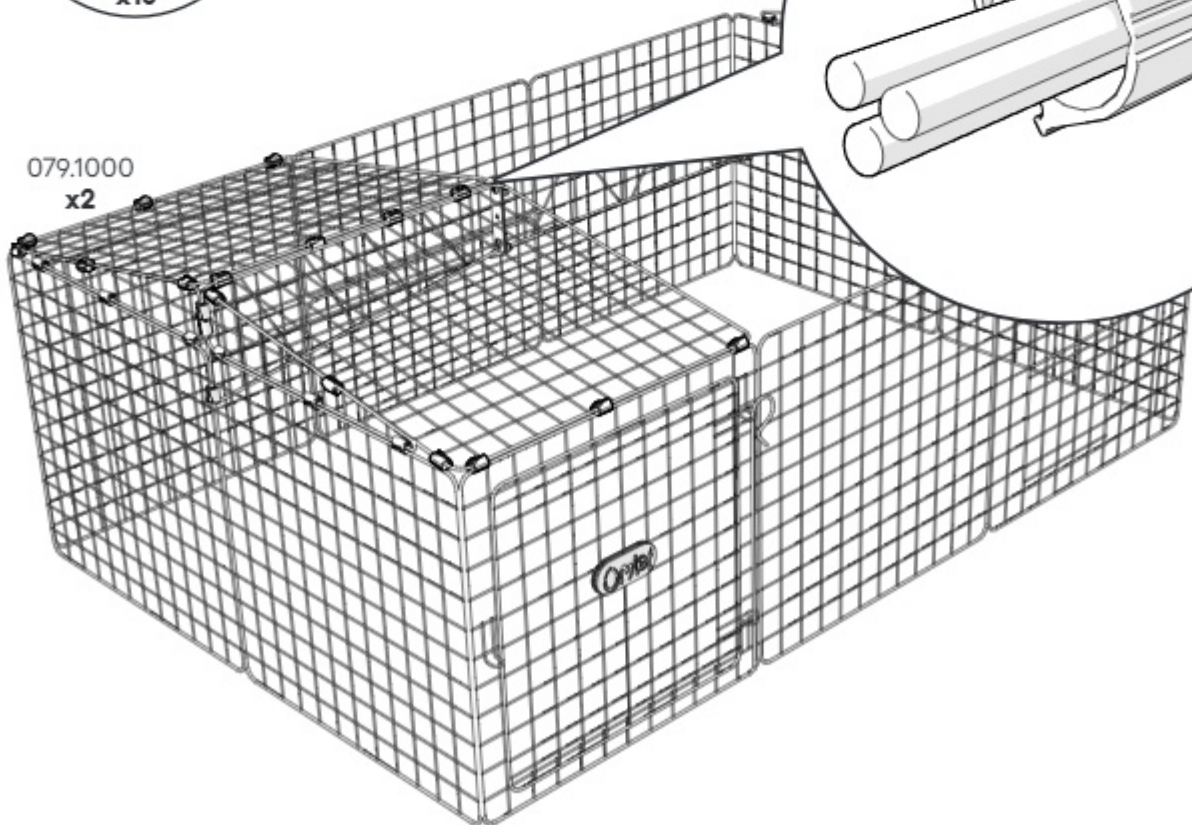

26

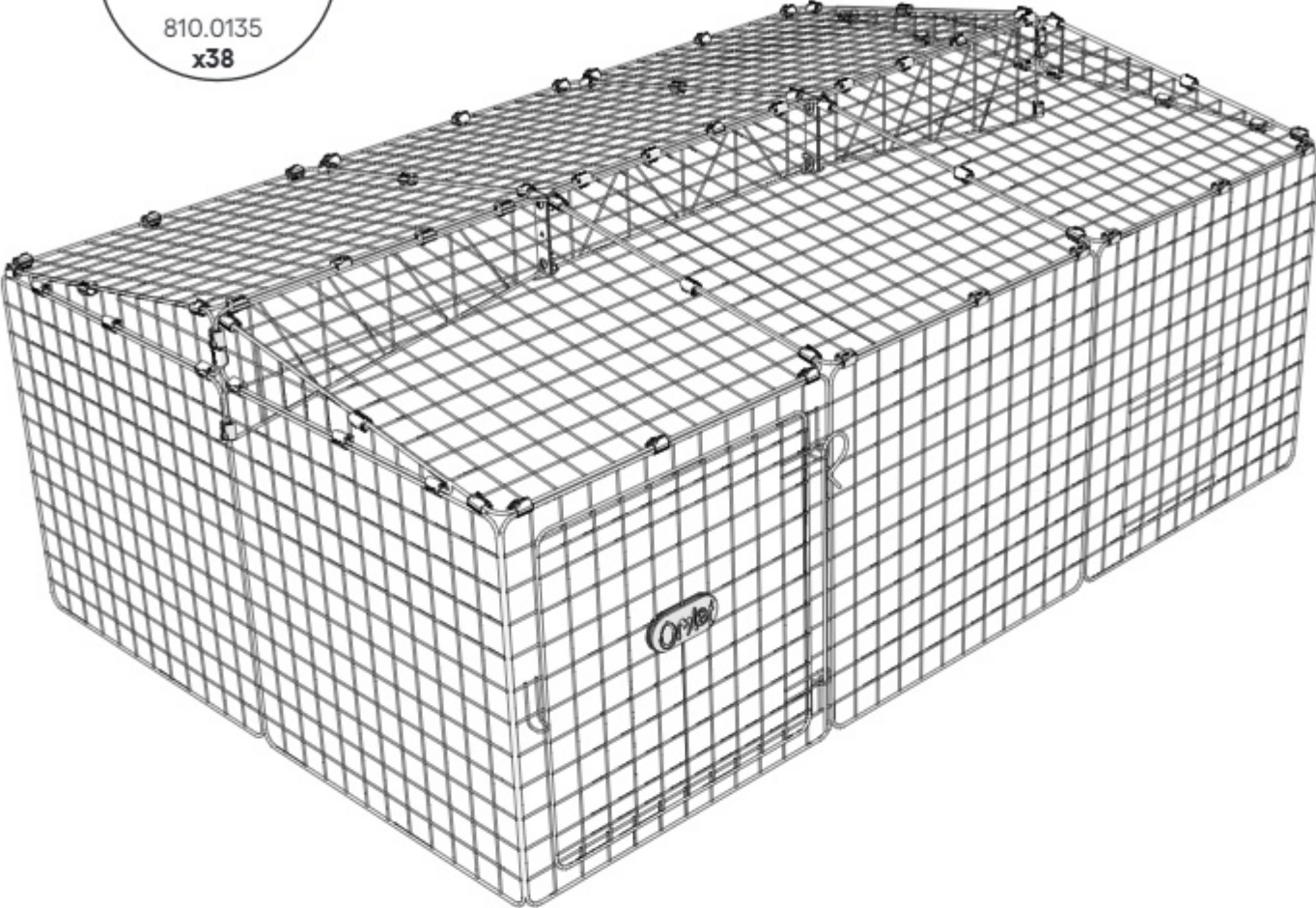

DOs

- Use your Zippi run for adult rabbits and guinea pigs. Once set up, observe your pets in the run. This is to ensure they are safe and secure in the run and the size of the holes in the mesh is appropriate for them.
- Make sure your pets always have access to fresh food and water.
- Regularly check your entire Zippi run making sure it is secure.
- Check the clips regularly. If any have been damaged or weakened, they should be replaced to keep the run secure.
- Move your pets to a secure location when moving or altering your Zippi run.
- Provide shade for your pets.

DON'Ts

- Let anyone climb inside the Zippi run unsupervised by a responsible adult - it is not a toy.
- Leave your pets unattended unless your Zippi run has a roof, skirts and underfloor mesh, otherwise your pets will be at risk of predators.
- Climb on the Zippi run. This is dangerous and can lead to the run being damaged
- Set up the Zippi Run on uneven ground as this will compromise the run's security. It can also cause a tripping hazard.
- Use a Zippi run beyond for what is specified, this shall be considered as improper use. Any direct commercial or industrial use is also deemed to be improper. Omlet is not liable for any damage resulting from such use. The user alone bears the risk.

Gebote

- Nutzen Sie das Zippi Gehege nur für ausgewachsene Kaninchen und Meerschweinchen. Nachdem Sie das Gehege aufgebaut haben, behalten Sie Ihre Haustiere beim Gebrauch im Auge. Damit stellen Sie sicher, dass die Tiere im Auslauf sind und die Gitterabstände entsprechend geeignet.
- Stellen Sie sicher, dass Ihr Haustier immer Zugang zu frischem Wasser und Futter hat.
- Überprüfen Sie regelmäßig das gesamte Zippi Gehege auf dessen Sicherheit.
- Überprüfen Sie die Clips regelmäßig. Falls diese beschädigt oder geschwächt sind, sollten sie umgehend ausgetauscht werden.
- Bringen Sie Ihre Haustiere an einem anderen Ort unter, während Sie das Zippi Gehege verstellen.
- Bieten Sie Ihren Tieren Schatten.

Verbote

- Lassen Sie niemanden unbeaufsichtigt durch einen verantwortungsvollen Erwachsenen im Zippi Gehege - dieses Produkt ist kein Spielzeug.
- Lassen Sie Ihre Haustiere nicht unbeaufsichtigt, es sei denn, Ihr Zippi Gehege hat ein Dach, eine Fuchssicherung und Unterbodengitter. Ihre Tiere sind sonst nicht sicher im Gehege.
- Klettern Sie nicht auf das Zippi Gehege. Dies ist gefährlich und kann zu Schäden am Gehege führen.
- Bauen Sie das Zippi Gehege nicht auf unebenem Gelände auf, da die Sicherheit des Geheges dadurch nicht mehr gegeben ist. Außerdem besteht dadurch Stolpergefahr.
- Jede abweichende, als die vorgesehene Nutzung wird als fehlerhaft angesehen. Jegliche direkte gewerbliche oder industrielle Nutzung gilt ebenfalls als unangemessen. Omlet haftet nicht für Schäden, die sich aus einer solchen Verwendung ergeben. Der Benutzer trägt das Risiko allein.

À faire

- Utilisez l'enclos Zippi pour des lapins et cochons d'Inde adultes. Une fois qu'il est opérationnel, observez comment se comportent vos animaux à l'intérieur. Il s'agit d'une mesure de sécurité pour vous assurer qu'ils y sont en sécurité et que les mailles sont d'une taille appropriée pour eux.
- Veillez à ce que vos animaux aient toujours accès à de l'eau et de la nourriture fraîches.
- Vérifiez régulièrement l'intégralité de l'enclos Zippi pour vous assurer qu'il soit bien sécurisé.
- Vérifiez régulièrement les attaches. Si l'une d'entre elles vous paraît endommagée ou usée, elles doivent toutes être remplacées pour que l'enclos reste correctement sécurisé.
- Sortez vos animaux de l'enclos Zippi pendant que vous le déplacez ou y apportez des modifications.
- N'hésitez pas à nous contacter par téléphone ou par email pour plus d'informations.

À ne pas faire

- Ne laissez pas un enfant s'introduire dans l'enclos Zippi sans qu'il ne soit supervisé par un adulte - ce n'est pas un jouet.
- À moins que votre enclos Zippi n'ait un toit, des jupes anti prédateurs et un grillage au sol, ne laissez jamais vos animaux sans surveillance dans l'enclos car ils seraient à la merci des prédateurs.
- Ne grimpez pas sur l'enclos : ceci est très dangereux pour vous comme pour vos animaux et pourrait également l'endommager.
- N'installez pas l'enclos Zippi sur une surface accidentée car cela compromettrait sa sécurité. Vous risqueriez également de trébucher dessus.
- N'utilisez pas l'enclos Zippi pour autre chose que sa fonction initiale. Toute utilisation autre de celles pour lesquelles il est conçu doit être considérée comme inadéquate. Tout usage commercial ou industriel sera également jugé incorrect. Omlet n'est en aucun cas responsable des éventuels problèmes résultant de telles utilisations. L'utilisateur en assumera pleinement les conséquences.

Do's

- Gebruik de Zippi ren voor volwassen konijnen en cavia's. Houd na het opzetten van de ren uw huisdieren in de gaten. Dit om er zeker van te zijn dat ze veilig zijn in de ren en het formaat van de mazen in het raster geschikt voor ze is.
- Zorg er altijd voor dat uw huisdieren toegang hebben tot vers water en voer.
- Controleer de Zippi ren regelmatig om er zeker van te zijn dat deze veilig is.
- Controleer de clips regelmatig. Indien er sprake is van schade of slijtage dienen alle clips te worden vervangen om de veiligheid van de ren te garanderen.
- Haal uw huisdieren uit de Zippi ren wanneer u deze verplaatst of wijzigt.
- Zorg voor voldoende schaduw voor uw huisdieren.

Don'ts

- Laat kinderen nooit zonder toezicht van een verantwoordelijke volwassene in de Zippi ren - dit is geen speelgoed.
- Laat uw huisdieren niet onbeheerd in de Zippi ren tenzij deze is voorzien van een dak, flensrand en vloerraster. Zonder dit vormen roofdieren een gevaar.
- Klim niet op de Zippi ren. Dit is gevaarlijk en kan de ren beschadigen.
- Zet de Zippi ren en het portaal nooit op een oneven ondergrond. Hierdoor kan de veiligheid en stabiliteit niet worden gegarandeerd.
- Gebruik van de Zippi ren op elke andere manier dan omschreven, wordt beschouwd als onjuist gebruik. Ook elke vorm van rechtstreekse commerciële of industriële toepassing wordt als onjuist beschouwd. Omlet is niet verantwoordelijk voor schade veroorzaakt door dergelijk gebruik. De gebruiker alleen is hiervoor verantwoordelijk.

Cosa fare

- Il Recinto Zippi va usato solo con conigli e porcellini d'India adulti. Una volta assemblato il recinto, controllate come i vostri animali interagiscono con il nuovo prodotto in modo da essere sicuri che questi siano protetti e sicuri al suo interno e che le dimensioni dei fori dei pannelli sia appropriato alla loro taglia.
- Accertatevi che i vostri animali abbiano sempre accesso a cibo e acqua fresca.
- Effettuate controlli regolari per accertarvi che il Recinto Zippi sia sempre sicuro e funzionale.
- Controllate regolarmente le clip e sostituitele immediatamente se queste sono danneggiate o indebolite.
- Muovete i vostri animali in un luogo protetto mentre spostate o apportate modifiche al recinto.
- Ricordatevi di creare delle zone ombrose nelle quali i vostri animali possano trovare riparo nelle calde giornate.

Cosa non fare

- Non arrampicatevi al Recinto Zippi: questo prodotto non è un giocattolo e va usato sempre con la supervisione di almeno un adulto responsabile.
- Non lasciate mai i vostri animali da soli e non supervisionati all'interno del recinto a meno che questo non sia dotato di tutte le protezioni, ovvero tela anti-tunnel, pavimento a rete e tetto, altrimenti i vostri animali potrebbero cadere vittima di predatori.
- Non sedetevi, arrampicatevi, saltate sopra o appendetevi al recinto: oltre ad essere pericoloso per voi e per i vostri animali, correte il rischio di danneggiarlo in modo irreparabile.
- Non assemblate il Recinto Zippi su una superficie o terreno irregolare: potrebbe compromettere la sicurezza del recinto oltre ad aumentare per voi il rischio di inciampo.
- Non usare il Recinto Zippi in modo diverso da quello espressamente consigliato nel manuale. Qualsiasi uso diverso da quello consigliato è da considerarsi improprio. Qualsiasi uso diretto commerciale o industriale è da considerarsi altrettanto improprio. Omlet non può essere ritenuta responsabile dei danni causati da un uso improprio o scorretto del prodotto. L'acquirente è da considerarsi il solo responsabile.

Se puede

- Utilizar el corral Zippi para conejos y cobayas adultas. Una vez montado, observar a las mascotas en el corral para asegurarse de que están seguros y protegidos y de que el tamaño de los agujeros de la malla es el adecuado.
- Ricordate di controllare che i vostri animali abbiano sempre accesso a cibo e acqua fresca.
- Comprobar con regularidad todo el recinto del Zippi para verificar que es seguro.
- Compruebe regularmente los clips. Si alguno se ha dañado o debilitado, debe ser sustituido para mantener el recorrido seguro.
- Trasladar las mascotas a un lugar seguro cuando se mueva o altere el recinto Zippi.
- Ricordatevi di creare delle zone ombrose nelle quali i vostri animali possano trovare riparo nelle calde giornate.

No se puede

- No permitir que nadie se suba al recinto Zippi sin la supervisión de un adulto responsable: no es un juguete.
- No dejar a las mascotas sin vigilancia a menos que el recinto Zippi tenga techo, bordes y malla bajo el suelo, de lo contrario las mascotas correrán el riesgo de ser atacadas por depredadores.
- No se suba al recinto Zippi. Es peligroso y puede dañar la el recinto.
- No instale el recinto Zippi en un terreno irregular, ya que esto compromete la seguridad del mismo. También puede causar peligro de tropiezo.
- No utilizar un recinto Zippi más allá de lo especificado ya que se considerará como uso inadecuado. También se considera impropio cualquier uso comercial o industrial directo. Omlet no se hace responsable de los daños derivados de dicho uso. El usuario es el único que corre el riesgo.

Gör

- Använd din Zippi för vuxna kaniner och marsvin. När den är monterad, studera dina husdjur på gården. Det är för att se till att de är säkra och att storleken på hålen i nätet är en bra storlek.
- Se till att dina husdjur alltid har tillgång till färskt vatten och mat.
- Gör regelbundna kontroller för att se till att gården är säker.
- Kontrollera klämmorna regelbundet. Om de är försvagade eller söndriga måste de bytas ut för att hålla gården säker.
- Flytta dina husdjur till en säker plats när du flyttar på eller ändrar gården.
- Se till att dina husdjur har tillgång till skugga.

Inte gör

- Låt inte någon klättra in på Zippi-gården utan övervakning av en vuxen - det är inte en leksak.
- Lämna inte dina husdjur ensamma om gården inte har tak, lister och underliggande nät monterade, eftersom djuren annars är under risk för rovdjur.
- Klättra inte på gården. Det är farligt och kan skada produkten.
- Sätt inte upp gården på en ojämn yta eftersom det gör att den inte är lika säker. Du riskerar dessutom att någon snubblar över den.
- All användning av Zippi utöver vad som är menat ses som olämplig användning. All direkt kommersiell eller industriell användning anses också olämplig. Omlet tar inget ansvar för skador orsakade av denna sorts användning, utan ägaren står för potentiella risker.

Gør

- Brug din Zippi løbegård til voksne kaniner og marsvin. Når den er sat op, skal du observere dine kæledyr i gården. Dette er for at sikre dig, at de er trygge og sikre i gården, og at størrelsen af netmaskerne er passende for dem.
- Sørg for, at dine kæledyr altid har adgang til frisk vand og foder.
- Kontroller jævnligt hele din Zippi løbegård, for at sikre dig at den er sikker.
- Kontroller klemmerne regelmæssigt. Hvis de er beskadiget eller svækket, skal de udskiftes for at holde gården sikker.
- Flyt dit kæledyr til et sikkert sted, inden du flytter eller ændrer din Zippi gård.
- Sørg for at dine kæledyr har adgang til skygge.

Gør ikke

- Lad ikke nogen kravle ind i Zippi gården uden at være under opsyn af en ansvarlig voksen - gården er ikke et legetøj.
- Lad ikke dit kæledyr være uden tilsyn, medmindre din Zippi gård har et tag, anti-tunnel paneler og netunderlag, ellers vil dine kæledyr være i fare for rovdyr.
- Du må ikke klatre på Zippi gården. Dette er farligt og kan føre til at gården bliver beskadiget.
- Sæt ikke Zippi gården op på et ujævnt underlag, da dette vil kompromittere løbegårdens sikkerhed. Det kan desuden udgøre en faldrisiko.
- Anvend ikke en Zippi løbegård til andet end det, der er angivet, da dette vil blive betragtet som ukorrekt brug. Enhver direkte kommerciel eller industriel anvendelse anses også for ukorrekt. Omlet er ikke ansvarlig for nogen skade som følge af denne brug. Brugeren alene bærer risikoen.

WE ASK. WE INVENT.

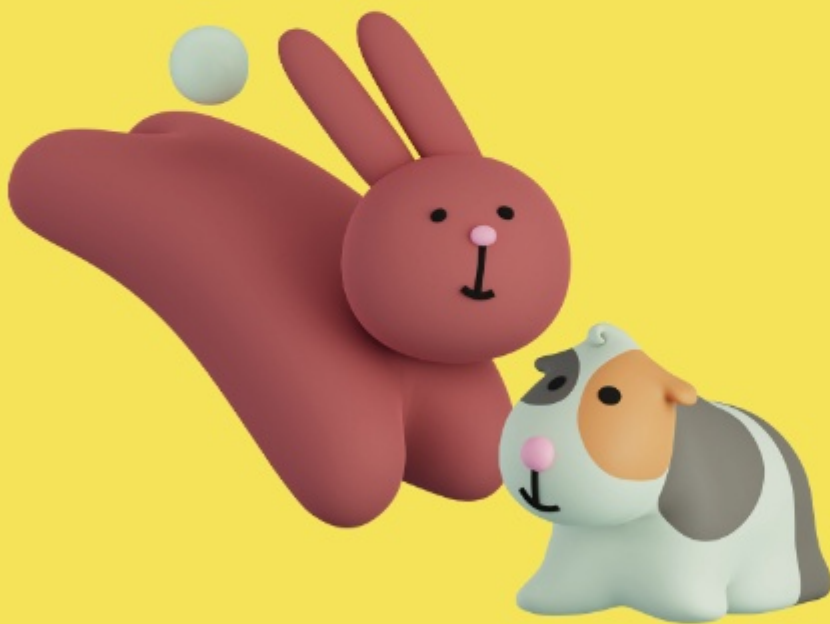

Omlet



Please
reuse &
recycle.

Omlet Ltd
The Old Malthouse, St John's Road, Banbury, OX16 5HX, UK
EU Responsible Person:
Rostock Fulfilment GmbH
Dorfstraße 15A, 18239 Satow, DE
Email (manufacturer & EU RP): info@omlet.com

Copyright Omlet Ltd. 2026
Design Registered, Patent Pending
Omlet Zippi Tunnel System is a Registered Trademark of Hebe Studio Ltd
Omlet is a Registered Trademark of Hebe Studio Ltd
820.0409F_Zippi Mesh Run Instruction Manual 01/06/2026



5 055358 813128 >